

PART NO.	DIAL FACE COLORS	PART NO.	POINTER COLOR
101-104-1X-X	BLACK BACKGROUND, WHITE CHARACTERS, WHITE ILLUMINATION	101-104-XB-X	BLACK
101-104-2X-X	WHITE BACKGROUND, BLACK CHARACTERS, GREEN ILLUMINATION	101-104-XR-X	RED
101-104-3X-X	BLACK BACKGROUND, WHITE CHARACTERS, RED ILLUMINATION	101-104-XW-X	WHITE

PART NO.	BEZEL STYLE
101-104-XX-1	BLACK
101-104-XX-2	POLISHED
101-104-XX-3	WHITE
101-104-XX-4	BLACK, AIRCRAFT

PART NO. 101-104-XX-X



P/N 101-104-2R-1
SCALE: 3/4



P/N 101-104-1R-1

DIAL FACE COLORS
POINTER COLOR
BEZEL COLOR & STYLE



P/N 101-104-3W-1
SCALE: 3/4



P/N 101-104-4R-2
SCALE: 3/4

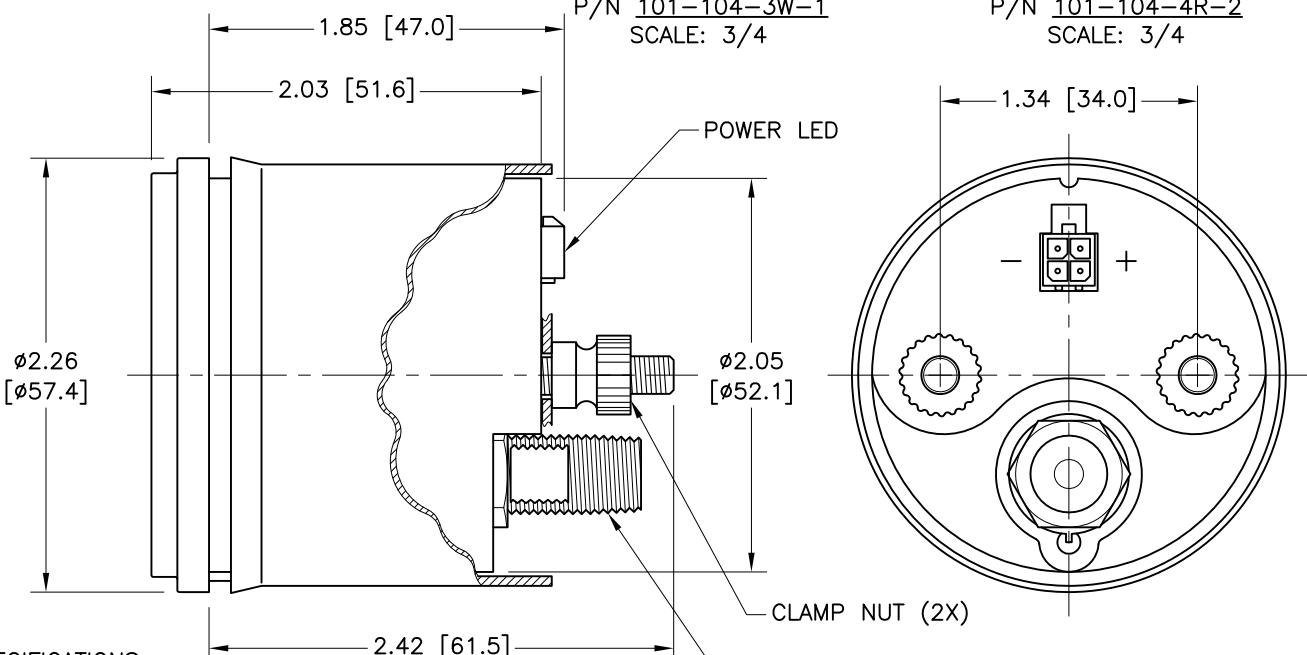

SPECIFICATIONS:

- DIAL:
SCALE: 270° ARC SWEEP.
RANGE: 0 - 100 PSI.
- ILLUMINATION:
INTERNAL 12 VDC (24 VDC ALSO AVAILABLE).
ILLUMINATED POINTER AND L.E.D. BACKLIT DIAL.
- POINTER COLOR:
STANDARD: RED FLUORESCENT (SEE TABLE).

REVISIONS					TOLERANCES	
REV.	DESCRIPTION	EO#	DATE	BY	UNLESS OTHERWISE SPECIFIED:	
1	ENGINEERING RELEASE	-	07/22/10	JAG	DIMENSIONS ARE IN INCHES, METRIC TOLERANCES ARE IN [BRACKETS]:	
2	REMOVED TAIL FROM POINTER	-	03/14/11	JAG	.X = .050 [1.27]	
3	ADDED GRAPHICS FOR DIAL COLOR & BEZEL CHOICES	-	08/19/11	JAG	.XX = .030 [0.76]	
A	NEW RELEASE PER ECO	ECO 582	02/08/12	JAG	.XXX = .010 [0.25]	
					FRACTIONS = 1/32	
					ANGLES = ±1°	
					SCALE: 1/1	

HI HEWITT INDUSTRIES OF LOS ANGELES

TITLE: 2" ENGINE OIL PRESSURE GAUGE

DRAWN BY: J.GUERRERO PART NO. 101-104-XX-X

APPR. BY: D.WISHART

DATE: 07/22/10 SHEET 1 OF 1

A