



## Installation Instructions for the Intercom Gear Warning Device II

**NOTE: This device is not approved for certified aircraft.**

### ***Congratulation on purchasing the Intercom Gear Warning Device for your aircraft***

With the use of headphone in the cockpit to reduce the cabin noise level along with increasing radio communications, the chance of not hearing the landing gear warning horn is becoming more of a prospect.

The Intercom Gear Warning Device is designed to lessen the possibility of not hearing the gear horn by providing a loud pulsing tone to the pilots headset and alerting that the gear is in the up position.

### **Theory of Operation**

The IGWD consist of two oscillators, one pulsing and the second, an audio generator that produces a warning tone when triggered by the landing gear safety switch or a combination of the Flap Light and Gear Light.

The audio output includes an adjustable level control so that the tone volume can be adjusted to provide a comfortable but noticeable level of warning tone.

The IGWD is activated or triggered when a combinations things happen.

- 1: the landing gear switch is in the UP position and
  - 2: the throttle is pulled back to the point that the landing gear warning horn sounds.
- OR
- 3: Flaps in Landing Position and the gear is up.

When any of these conditions occur, the audio oscillator alarms the pilot that the landing gear is still in the UP position.

### **Installation**

The installation of the IGWD requires nine wire connections to the aircraft systems. These connections are terminated in a 9 pin plug which allows the IGWD to be unplugged for easy servicing should it be required. Wire gage of 22 or 24 can be used for all connections. The connections are the following.

- Pin 1. aircraft electrical ground
- Pin 2. aircraft PLUS voltage, either 12 or 24 VDC
- Pin 3. Audio from radio or audio panel (600 ohm, low level audio)
- Pin 4. Trigger lead connected to the Jumper Set 1.
- Pin 5. Trigger lead connected to the Jumper Set 2
- Pin 6. Audio output to intercom input. (600 ohm, level audio)
- Pin 7. Connection for Alert Light (LED), Minus lead.
- Pin 8. Connection for Alert Light (LED), Plus lead.
- Pin 9. Input for TEST switch. (Optional)

**REFER TO THE AIRCRAFTS WIRING DIAGRAMS FOR PROPER CONNECTIONS.**

### **Trigger Inputs**

The IGWD can be triggered in one of two methods.

1. For single input triggering, the landing gear throttle safety switch in connected to the IGWD.
2. For dual inputs, Flap and Gear detecting.

For the simplest installation, the landing gear safety can be used. Locate the throttle safety and determine if the voltage to the landing gear horn is a pull to plus voltage or pull to ground. Connect a wire from the side of the switch that goes to the horn and route the wire to the IGWD and connect to PIN 4 of the 9 pin socket housing.

The second method for connection is to use the Landing gear UP light and Flap UP light or Switch's. This ensures that if the flaps are lowered before the landing gear, the alarm will sound. The following conditions will trigger the IGWD.

1. Gear UP light ON, Flap UP light ON, NO WARNING TONE.
2. Gear UP light OFF, Flap UP light ON, NO WARNING TONE
3. Gear UP light OFF, Flap UP light OFF, NO WARNING TONE
4. **Gear UP light ON, Flap UP light OUT, WARNING TONE.**

Connect the landing gear UP light to pin 5 of the 9 pin socket.  
Connect the flap UP light to pin 4 of the 9 pin socket.

The trigger inputs are routed through a series of jumpers on the circuit board to two optical couplers. Each optical coupler consist of an LED or light emitting diode that eliminates a photo transistor. The optical coupler provides isolation between the aircrafts circuit and IGWD. It also allows for either a Plus voltage or Ground trigger signal depending on the jumper configuration.

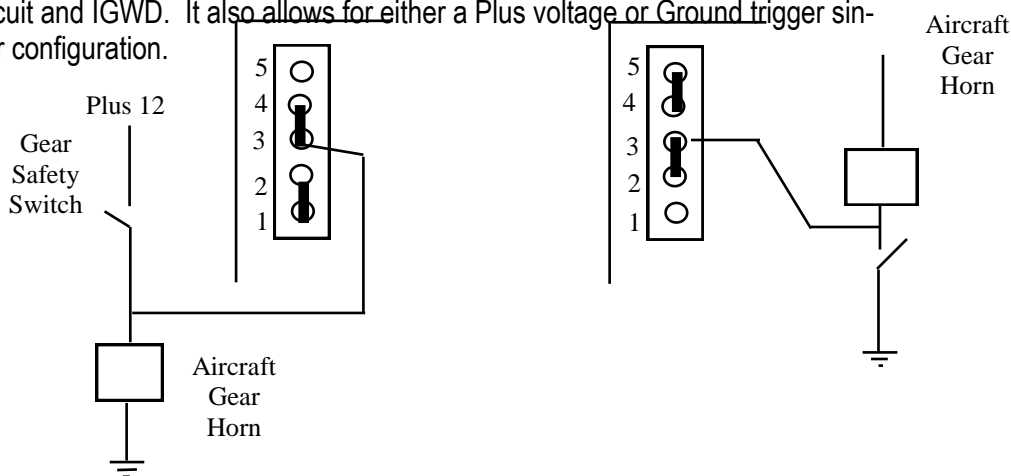

The above drawings show the jumper configuration for Plus or Ground triggering. The jumpers can be changed by removing the black jumper housing plug and moving to the desired pin configuration.

There are two sets of jumpers consisting of five pins, one each for the landing gear and flaps input. The jumper strip are labeled on the printed circuit board as JUMPER SET 1 and JUMPER SET 2.

If the installation is for a single trigger connection from the landing gear safety switch on the throttle, use the FLAPS/GEAR jumper strip.

For installation using the Landing Gear UP light and the Flap UP light, use both jumper strips with the Gear UP source to the LANDING GEAR jumper strip and the Flap UP light source to the FLAP/GEAR jumper strip.

Refer to the schematic for information on connecting to the landing gear and flap lights.

### **Switches 1 and 2**

Located next to the FLAP/GEAR jumper strip is a four position DIP (dual inline pack) switch module and the switches are labeled 1,2,3 and 4, as well as ON.

Switches 1 and 2 are part of the trigger circuits and depending on the trigger voltage, they are either on or off. For NEGATIVE or pull to Ground circuits, switches 1 and 2 are set to the **ON** position. In PLUS or pull to positive voltage, switches 1 and 2 are set to **OFF**.

Switches 3 and 4 are covered later in the installation.

### **Plus Voltage Connection**

Pin 2, the Plus Voltage connection is connected to the aircraft positive voltage system. A fuse rated at 1 amp should be connected either in line with the power lead or the power lead connected to a circuit breaker.

### **Audio Input and Output**

The IGWD is designed to be connected in series with the pilots headphone audio. Pin 3 is the audio input and Pin 6 is the audio output. The connection can be made at the headphone jack by removing the lead from the TIP terminal on the jack and connecting it to a lead from Pin 3. A wire from Pin 6 is then connected to the TIP terminal of the headphone jack.

### **Stereo Headphones**

If a stereo headphone jack is installed, repeat the above steps. There are no connections from the IGWD that need to be made to the RING terminal.

### **Testing the IGWD**

After the connections are made, the unit is ready for testing. Check to see that switches 3 and 4 are set to ON. Turn on the aircraft's Battery or Master switch and while listening in the headphones, a tone should be heard in the pilots headphones. Adjust the level control pot (VR2) on the circuit board for the desired tone level. After the tone level is set to the desired level, move switch 4 to the OFF position.

If the IGWD was wired to a stereo jack, locate control pot VR3 on the circuit board and while listening to audio from the radio, adjust VR3 to balance the level between the two channels. VR3 controls the headphone volume from the audio input to the IGWD.

### **Switch 3**

The IGWD includes a relay in the audio circuit that is always on when power is supplied to the unit. In the event of power failure to the IGWD, the relay will drop out and connect the pilots headphone directly to the audio input, ensuring that the audio path is always maintained.

To test the operation of the relay, while listening in the headphones, move Switch 3 to the OFF position, a change in audio level should be heard. After testing, move Switch 3 back to the ON position.

### **NOTE: Switch Positions after testing.**

After the wiring has been checked and before replacing the lid, check to see that the four switches are in the following position.

#### **Position for Positive Triggering.**

1. OFF
2. OFF
3. ON
4. OFF

#### **Position for Negative Triggering**

1. ON
2. ON
3. ON
4. OFF

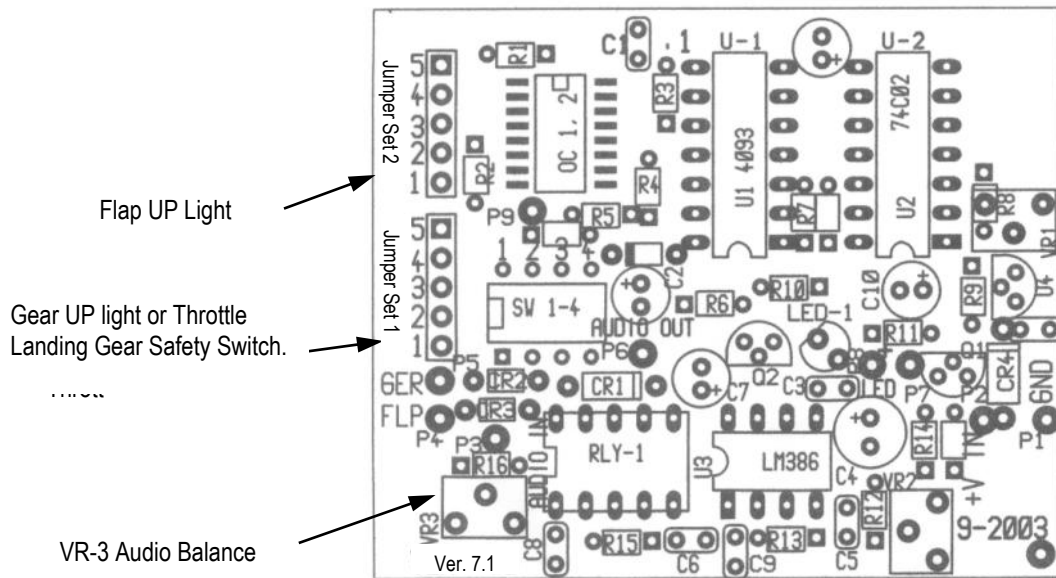

VR-2 Tone Volume Control

### Warning LED

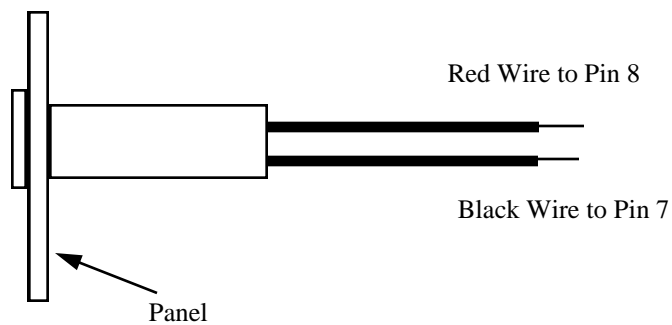

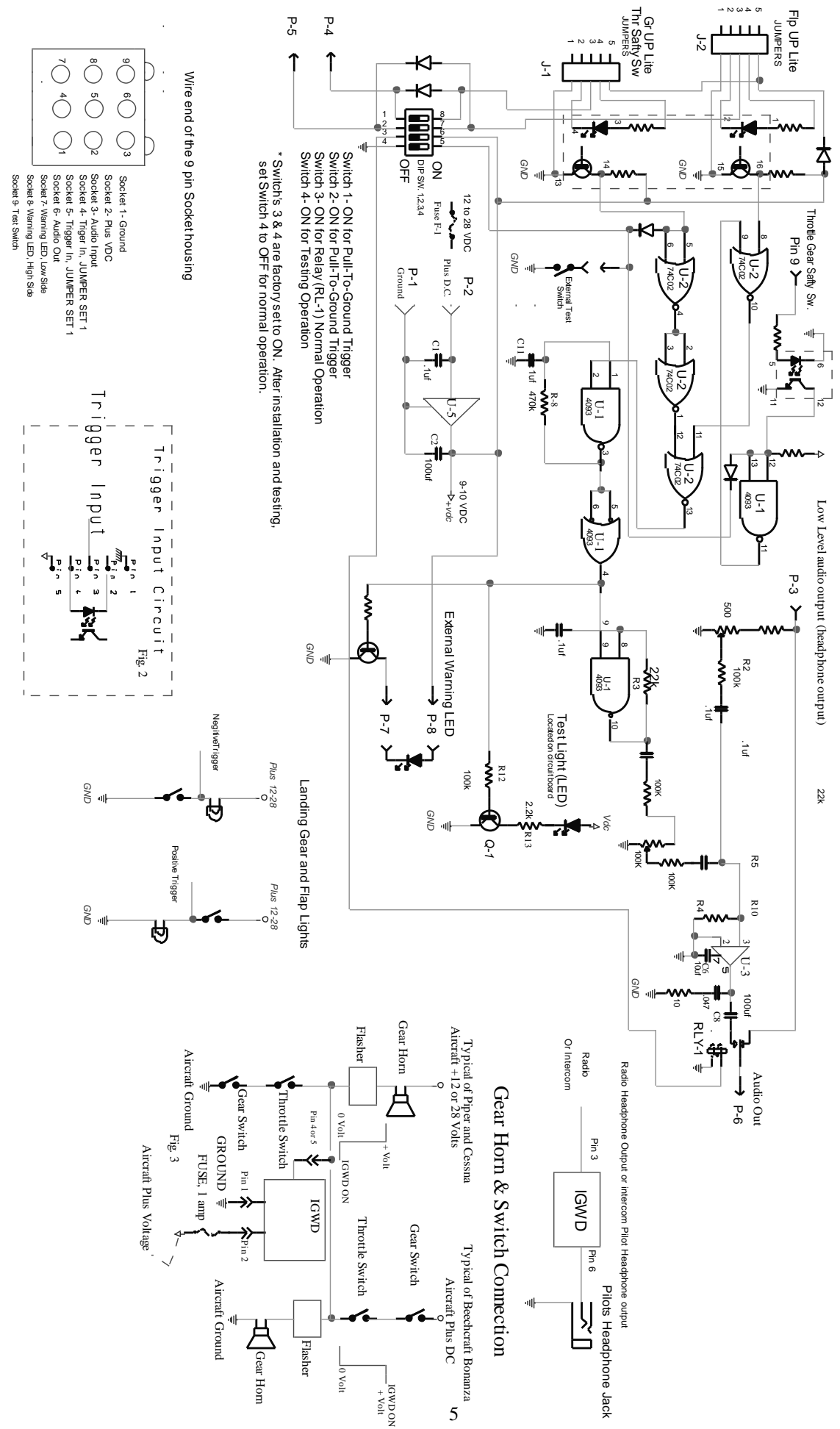

\* Switches 3 & 4 are factory set to ON. After installation and testing, set Switch 4 to OFF for normal operation.

Wire end of the 9 pin Socket housing

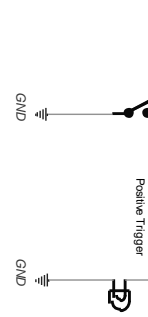
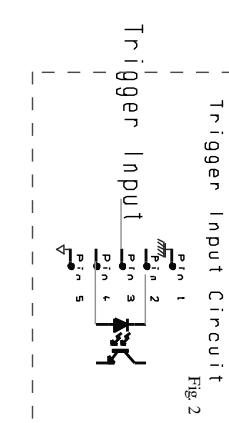
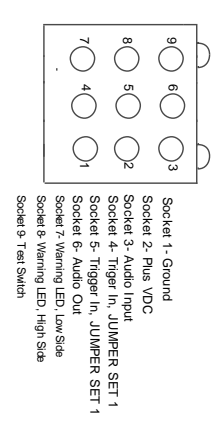

### Gear Horn & Switch Connection

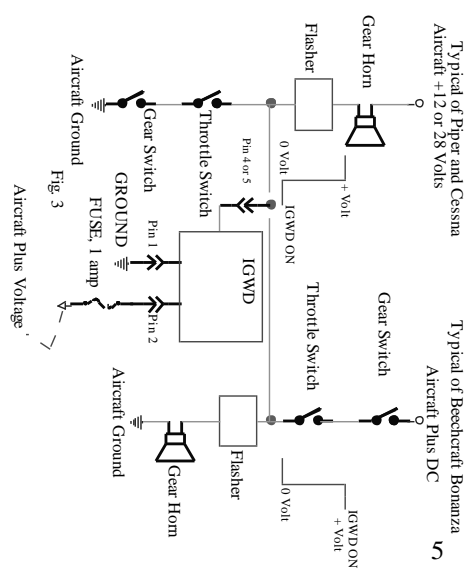
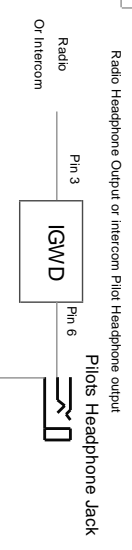

Fig. 3



Radio Headphone Output or Intercom Pilot Headphone output

## **TEST SWITCH**

Some pilots may find it advantageous to test the IGWD, referring to Fig. 2, a push button switch can be connected to Pin 9 and GROUND. Pushing the switch will activate the IGWD allowing the unit to be tested.

## **Warning Light**

A Red LED is included with the IGWD that can be mounted in the instrument panel and wired to the unit. The LED is a press fit type that is mounted in a 1/4" diameter hole and has two leads, a RED and a BLACK. The RED lead is connected to a wire to Pin 8 and the BLACK is connected to a wire from Pin 7 of the connector block.

After completing the wiring and testing of the unit, replace the cover and mount the IGWD using the two mounting tabs to complete the installation.

**NOTE: This device is not approved for certified aircraft.**

## **Technical Information**

Size: 3.2"L x 2.3"W x 1.0"H  
Power Requirements: 12 to 28 VDC @ 20ma.  
Trigger Input: Pos. Or Neg. Voltage level, on board jumper selected.  
Audio Output Level: Adjustable:  
Weight, 1Ooz.

### **3-YEAR UNCONDITIONAL WARRANTY**

"FlightTech Intercoms" are warranted against defects for three years from date of purchase from authorized distributors and dealers. Within the three year period, the FlightTech Intercom will be repaired or exchanged (at our option) without charge for parts or labor. Simply return your intercom along with proof of purchase, return postage of \$6.00 (within USA) and it will be repaired or replaced within two weeks. Warranty does not cover transportation cost or product misuse, accidental damage, owner tampering or reworking.

Except as provided herein, either FlightTech Intercoms or DesignTech Systems makes no warranties, expressed or implied, including warranties or merchantability and fitness for a particular purpose.

**NOTE:** Some states do not permit limitations or exclusions of implied warranties, therefore, the aforesaid limitations (s) may not apply to the purchaser.

DesignTech Systems, Inc. / FlightTech Intercoms  
P.O. Box 828, Downers Grove, IL 60515  
(630) 324-8199 FAX 866-896-4431  
Web Site, <http://www.flighttech.com> E-mail, [info@flighttech.com](mailto:info@flighttech.com)