

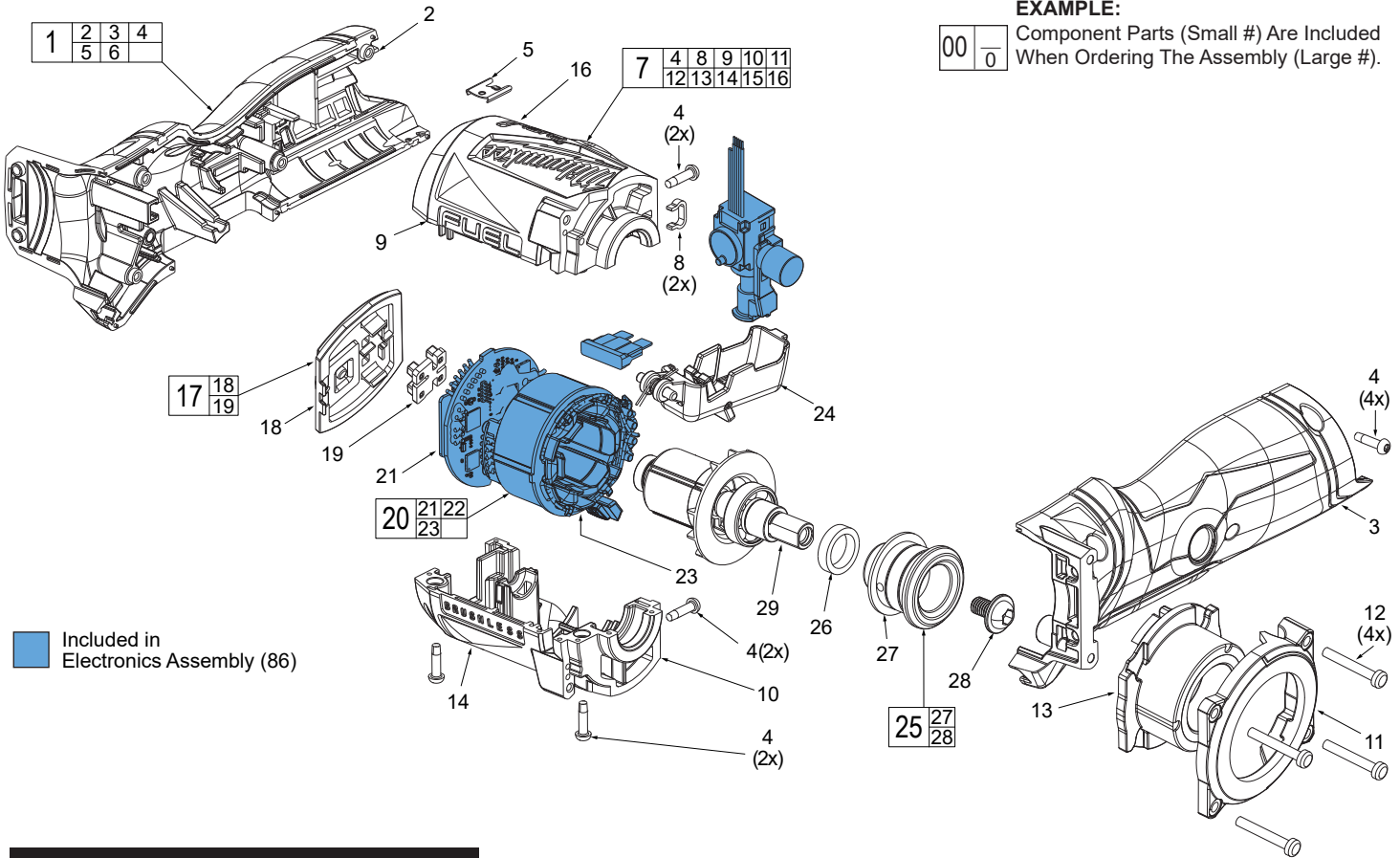

SERVICE PARTS LIST

BULLETIN NO.
54-38-2485

SPECIFY CATALOG NO. AND SERIAL NO. WHEN ORDERING PARTS			REVISED BULLETIN	DATE
M12 FUEL 3/8" x 13" BAND FILE				Oct. 2022
CATALOG NO.	2483-20	STARTING SERIAL NO.	N34A	
			WIRING INSTRUCTION SEE PAGE 2	



EXAMPLE:

Component Parts (Small #) Are Included When Ordering The Assembly (Large #).

 Included in Electronics Assembly (86)

SERVICE PARTS EXPLODED VIEW

FIG.	PART NO.	DESCRIPTION OF PART	NO. REQ.
1	14-34-0044	Handle Housing Kit	(1)
2	-----	Handle Housing Support	(1)
3	-----	Handle Housing Cover	(1)
4	06-82-1080	M3 x 14mm St Screw	(10)
5	42-70-0058	Handle Housing Connection Clip	(1)
6	10-20-7040	Warning Label (Not Shown)	(1)
7	14-38-0062	Motor Housing Kit	(1)
8	42-70-0038	Motor Housing Connector Clip	(2)
9	-----	Motor Housing Support	(1)
10	-----	Motor Housing Cover	(1)
11	43-76-0820	Arm Housing	(1)
12	06-82-0135	M3 x 1.34mm PH T-10 Screw	(4)
13	43-78-0090	Arm Hub Support	(1)
14	12-20-2492	Service Nameplate (Not Shown)	(1)
15	10-20-7041	Warning Label (Not Shown)	(1)
16	-----	Fuel Gauge Label	(1)
17	14-46-0588	UI Kit	(1)
18	-----	UI Bezel Panel	(1)
19	-----	Bezel lens	(1)
20	14-20-0159	Electronics Assembly	(1)
21	-----	PCBA	(1)
22	05-88-0106	M2 x .89mm PT Stator Screw (not shown)	(4)
23	-----	Stator	(1)
24	14-46-0584	Trigger Assembly	(1)
25	14-46-0587	Drive Hub Kit	(1)
26	-----	Wool Felt	(1)
27	-----	Drive Hub	(1)
28	-----	Round Head Blade Bolt	(1)
29	14-50-0049	Rotor & Output Shaft Assembly	(1)

SCREW TORQUE SPECIFICATIONS

FIG.	PART NO.	WHERE USED	SEAT TORQUE	
			(kgf-cm)	(lb-in)
4	06-82-1080	Housing Support	7±1	6±1
12	06-82-0135	Motor Housing	9±1	8±1
28	-----	Drive Hub	35±5	30±4
34	-----	Cam	7±.5	6±.5
37	-----	Hub Cover	15±2	13±2
43	-----	Arm Shoe	22±3	19±2
53	-----	Roller Assy	10±1	9±1

SERVICE PARTS EXPLODED VIEW - continued

NOTE: If entire 3/8" arm service assembly shown below is needed, order part # 14-46-0596. (fig.55)

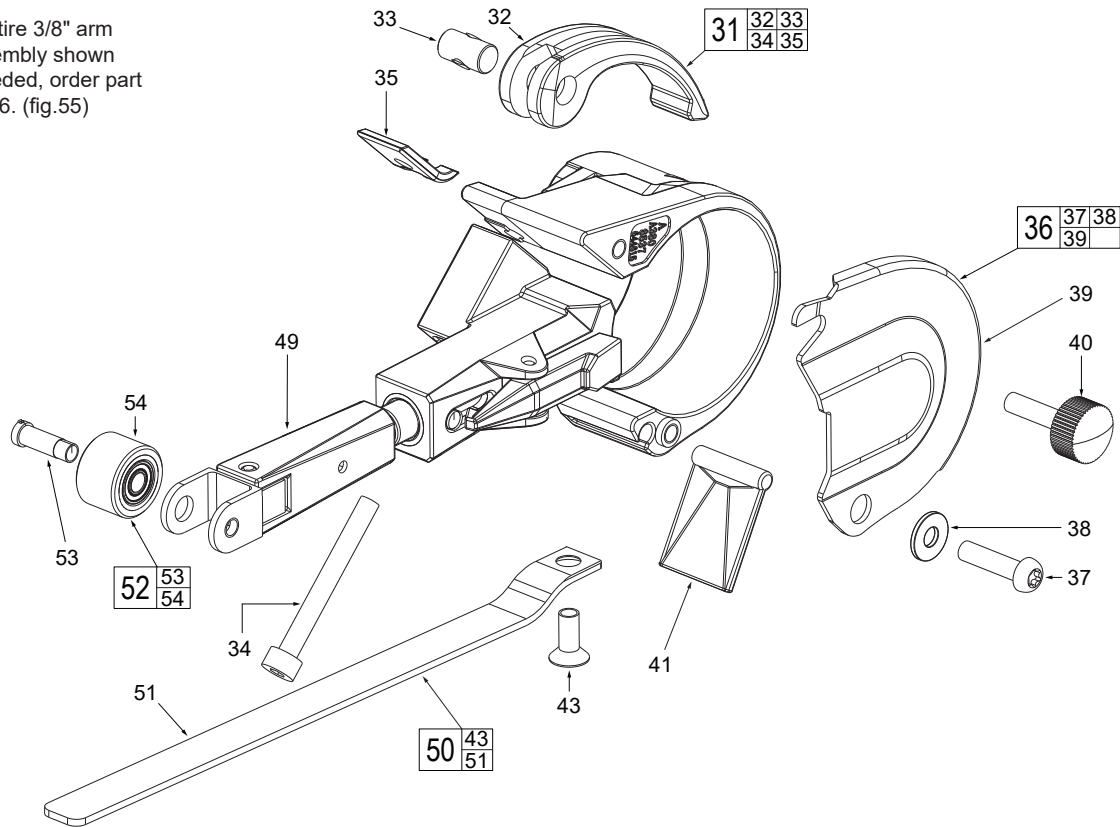

FIG.	PART NO.	DESCRIPTION OF PART	NO. REQ.	FIG.	PART NO.	DESCRIPTION OF PART	NO. REQ.
31	14-46-0577	Quick Release Lever Kit	(1)	41	43-54-1001	Spark Flap	(1)
32	-----	Quick Release Lever	(1)	43	-----	M4 x 18mm FH T-20 Screw	(1)
33	-----	Cam Pin	(1)	49	14-46-0574	3/8" Arm Hub/Extension Assembly	(1)
34	-----	M4 x 18mm CH Hex Recess Screw	(1)	50	14-46-0573	3/8" Arm Shoe Kit	(1)
35	-----	Pom Spacer	(1)	51	-----	13" Arm Shoe	(1)
36	14-46-0578	Hub Cover Kit	(1)	52	14-46-0593	3/8" Roller with Bolt Kit	(1)
37	-----	M4 x 16mm PH T-20 Screw	(1)	53	-----	3/8" Contact Wheel Bolt	(1)
38	-----	Washer	(1)	54	-----	3/8" Roller Service Assembly	(1)
39	-----	Hub Cover	(1)	55	14-46-0596	3/8" Arm Service Assembly	(1)
40	06-87-2405	Hub Cover Thumb Screw	(1)				

SERVICE WIRING DIAGRAM

- As an aid to reassembly, take notice of wire routing and position in wire guides and traps while dismantling tool.
- Avoid pinched wires, be sure that all wires and sleeves are pressed completely down in wire guides and traps.
- Be sure that all components of the electronics kit are seated firmly and squarely in the housing recesses.
- Prior to installing the housing cover onto the housing support, be sure that there are no interferences.

