



SERVICE PARTS LIST

BULLETIN NO.
54-49-2596

SPECIFY CATALOG NO. AND SERIAL NO. WHEN ORDERING PARTS		REVISED BULLETIN	DATE
M12™ RADIO + CHARGER		54-49-2595	Jan. 2021
CATALOG NO.	2951-20	WIRING INSTRUCTION	
	SERIAL NUMBER	L47B	

EXAMPLE:



Component Parts (Small #)
Are Included When Ordering
The Assembly (Large #).

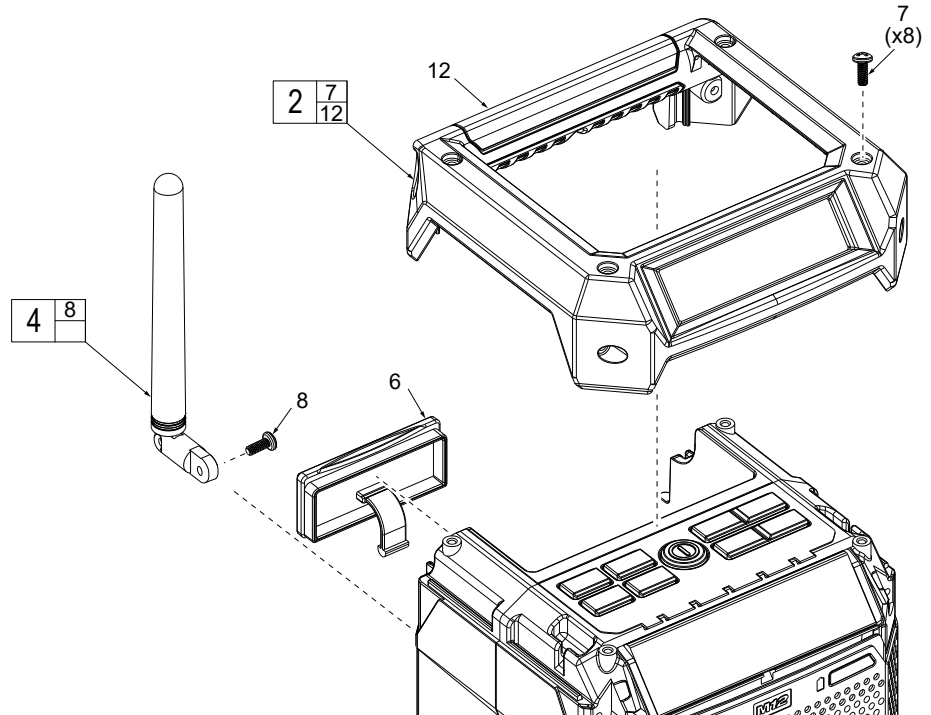

FIG.	PART NO.	DESCRIPTION OF PART	NO. REQ.
2	14-38-0175	Top Housing Kit	(1)
3	14-38-0177	Bottom Housing Kit	(1)
4	42-09-0012	Antenna Kit	(1)
5	31-21-0023	Backup Battery Door Kit	(1)
6	31-21-0005	Door Cover	(1)
7	-----	3 x 10 Pan Hd. T-10 Screw	(17)
8	-----	2.6 x 6 Flat Hd. Phillips Screw	(1)
9	-----	3 x 10 Pan Hd Phillips Screw	(1)
10	23-81-0710	Wall Transformer / AC Adapter (Not Shown)	(1)
11	12-20-2951	Service Nameplate (Not Shown)	(1)
12	-----	Top Housing	(1)
13	-----	Bottom Housing	(1)

FIG. NOTES

11 A clean, dry surface is essential for proper performance for any adhesive system. The area intended for application of any adhesive label or nameplate must be prepared by cleaning with isopropyl alcohol. The solvent is to be applied with a clean, lint free applicator and the surface allowed to dry before applying the label or nameplate.

