

MECHANICAL

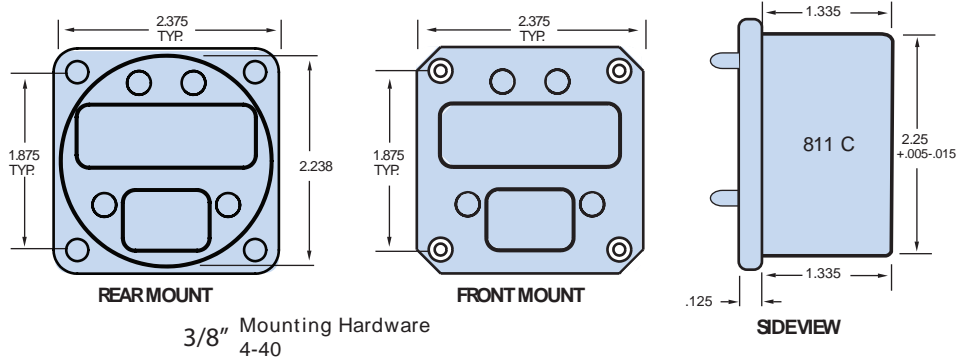

ELECTRICAL

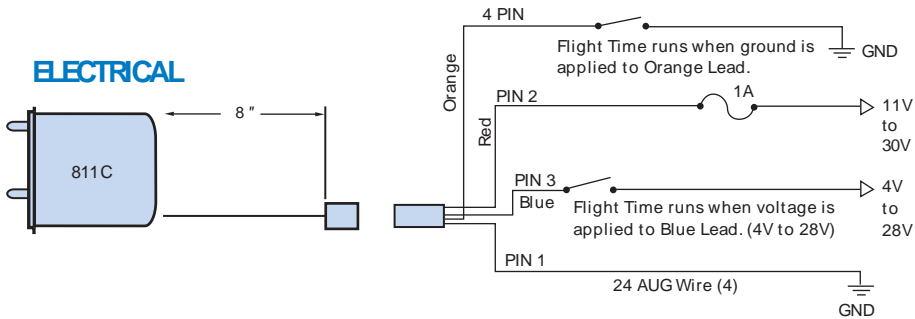

SPECIFICATIONS

- Six-digit display on all three functions.
- Time Function: 12 hour or 24 hour format.
- Flight Time: Records in 99:59 standard.
- Elapsed Time Count Up: Starts in minutes, seconds, then hours, minutes up to 99:59 hrs.
- Count Down Time: Settable from 99 hours, 59 minutes.
- Count Down Time Alarm: Activates at zero when counting down.
- LED Displays: Sunlight readable.
- Battery Type: CR2032.
- Polarizing Filter.
- Input Current: .2 Amps.
- Input Voltage: 11 to 30 Volts
- Weight: 5 ounces MAX.
- Warranty: 1 year.

M811C DIGITAL CLOCK

UTC / LOCAL TIME - FLIGHT TIME
ELAPSED TIME - Count Up / Count Down



FEATURES

- Toggle button control system is natural.
- Bright sunlight readable LED displays.
- Local Time 12 or 24 hour format.
- Flight Time recorded in hours and minutes.
- Flight Time count up to 99 hours 59 minutes.
- Elapsed Time with countdown timer with alarm.
- Crystal precision time reference.

MODEL 811C OPERATION

Davtron Model 811C has an internal lithium battery before it leaves the factory. All three functions of the clock are activated and working. At this time, Davtron sets the clock to accurate time (W.W.V). The Time, Flight Time and Elapsed Time will hold approximately 5 years without any additional power. No aircraft keep-alive necessary. Aircraft power is required to light the display only.

DISPLAY SELECT

The switch marked Time/F.T./E.T. is a three position switch that selects the function to be displayed.

TIME

When the time function is selected, the proper time will read in hours, minutes, and seconds. The time channel may be set to local time or G.M.T.

SETTING TO ACCURATE TIME

Davtron sets the clock to the correct GMT time when it leaves the factory. To change hour, push Dim/Bright switch to 1hr up position. Each press or just holding it in the 1hr up position will increase time by one hour. This setting does not affect the minutes or seconds. The switch marked Set is for changing minutes or seconds. When you hold Set switch in UP mode, minutes will count one per second until 5 seconds elapse, then minutes speed up to 5 minutes per second. When you hold Set switch in the D, down position the seconds reset to zero. During the time the clock is being set, the Elapsed Time and Flight Time still continue to operate normally. The Set switch is a momentary switch and automatically returns to the center position.

FLIGHT TIME RECORDER

When the Flight Time channel is selected, the actual time in flight will be displayed in hours, minutes, and seconds. The Flight Time channel is controlled by either applying a voltage to the blue control lead or ground to the orange control lead. Anytime during flight the pilot may check total time in flight. When the aircraft has landed, the pilot can record total Flight Time. The pilot can have total Flight Time on a trip with a number of stops if he avoids returning the Flight Time recorder to zero. The Flight Time recorder will

total time up to 99 hours. Normally it is recommended that the Flight Time recorder be zeroed on the pre start up check list of the aircraft. The Flight Time can be zeroed by holding the switch to ZERO for 3 seconds.

ELAPSED TIME METER

When the Elapsed Time channel is selected the Elapsed Time meter will read in hours, minutes, and seconds. This recorder is fully controlled by the pilot from the front panel. It may be started, stopped and returned to zero for elapsed time, approach time, etc. Total time is up to 99 hours.

ELAPSED TIME COUNT DOWN

When the Elapsed Time channel is selected and the toggle that controls the ET channel is at Stop you're ready to set time for the count down time. Entering the time is identical to setting time. Once time is updated for ET, push toggle to run and time will begin to count down. When the count reaches zero the displays will flash. Toggle to the Stop position to stop the counting and flashing, but then you can toggle back to RUN to continue counting. Toggle to zero to reset to zero or you can set back to the previous set time by holding switch to ZERO for 3 seconds.

DIM POSITION FOR DISPLAY

For night operation a Dim position is provided. Normal position is B or bright.

CHANGING CLOCK FROM 24 to 12HR

With unit off, hold Bright/Dim switch in 1hr up position, turn on unit. Unit is now 12HR. Repeat steps to switch back.

BATTERY REMOVAL We recommend to remove & replace CR2032 battery every 5 years.

This switch makes minor time corrections.

Position # ① (up) is a momentary position and sets the clock one minute forward for every second held in the UP position. After 5 seconds, minutes speed up to 5 per second.

Position # ② is the normal position.

Position # ③ (D) is a momentary position and resets seconds to zero when selected or held.

This switch sets Bright/Dim, and makes one hour changes.

Position # ① (B) is the Bright position of the display for daytime use.

Position # ② (Dim) is for nighttime use.

Position # ③ (1 hr. up) is a momentary position and sets the clock 1 hour ahead for every time the switch is moved to this position and released.

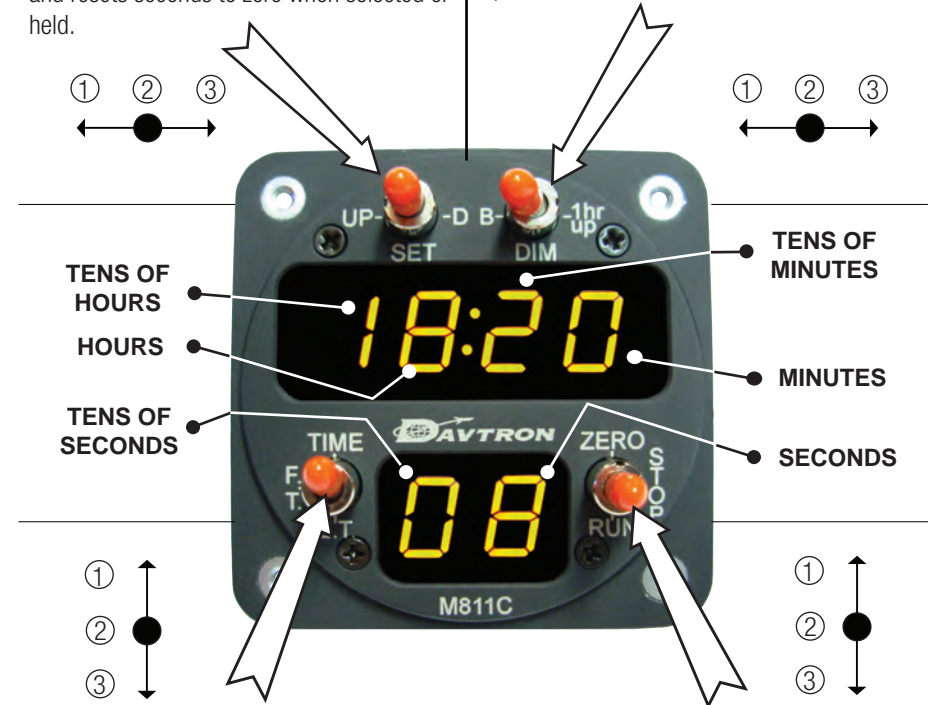

This switch selects which channel is to be displayed.

Position # ① (Time) selects real time. This channel may be set to G.M.T. time or local time. Reads in hours, minutes and seconds.

Position # ② (F.T.) selects Flight Time, reads in hours, minutes and seconds of actual flight.

Position # ③ (E.T.) selects Elapsed Time, reads in hours, minutes and seconds.

This switch controls the Elapsed Time meter.

Position # ① (Zero) is a momentary position and resets the Elapsed Time meter to zero. The switch returns to position #2 when released.

Position # ② (Stop) will stop the Elapsed Time meter.

Position # ③ (Run) starts the Elapsed Time meter or Count Down Timer.