

MGL Avionics AvioGuard

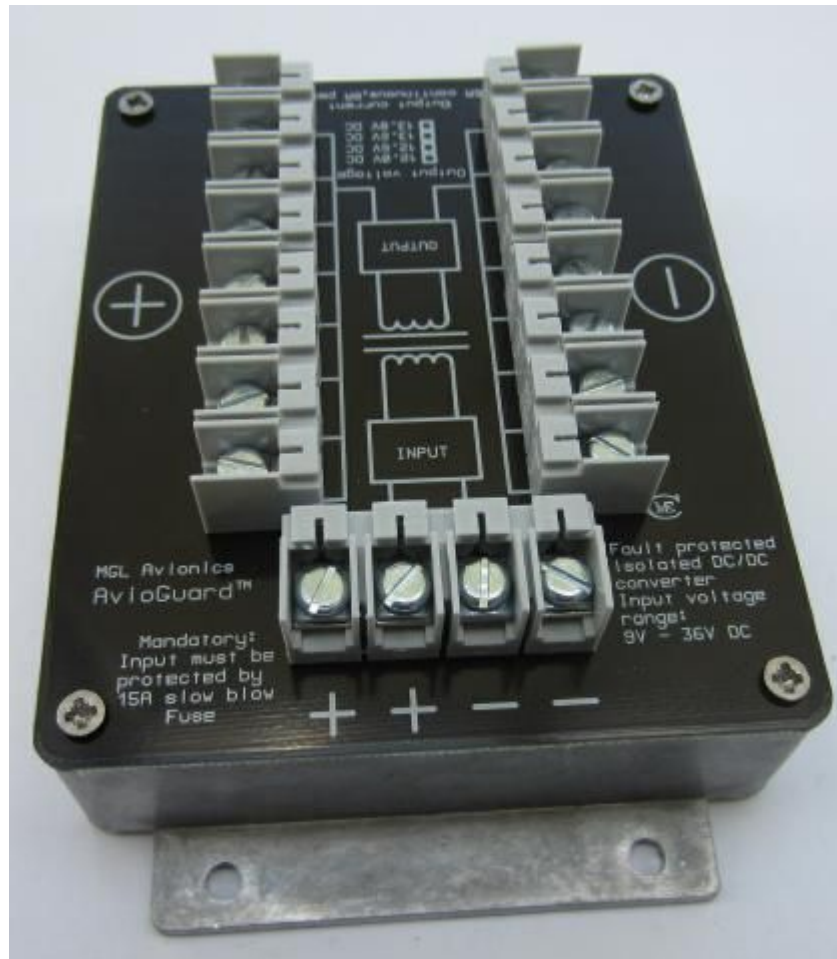

Fault protected, wide input range, isolated, DC to DC converter for avionics applications

General

The MGL Avionics AvioGuard is a fault protected DC to DC converter.

It is able to convert poor quality DC input from 9V to 36V to a stable, clean DC output voltage of 12V to 13.8V (model dependent).

The input is fully isolated from the output. Power is transferred by means of a high frequency magnetic field.

Intended usage

1. Secure power supply of sensitive avionics in an aircraft installation.
2. DO-160 power supply qualification of avionics equipment that does not conform.
3. Protection of avionics against the effects of ground faults.
4. Simplification of avionics emergency backup supply design.
5. Lockout of under/over-range voltage supply from avionics.
6. Avionics radio transmitter output power maximizer (most radios will output designed power at 13.8V).
7. Step down converter from 24/28V aircraft supplies to 12V equipment.

Typical AvioGuard supplied devices

1. EFIS systems
2. Electronic engine monitoring devices
3. Aviation radios and transceivers (VHF, HF)
4. Aviation navigation radios
5. Aviation transponders
6. ADSB receivers and transceivers
7. GPS receivers
8. Intercom systems

Devices that should not be supplied using AvioGuard

In principle, AvioGuard can supply any device falling within its output current and voltage range, however it is primarily intended as avionics supply. Connecting other electrical systems to the AvioGuard may compromise its intended use or even completely nullify its advantages (for example bridging the isolation).

AvioGuard is intended to produce a very clean DC supply for sensitive equipment. If you use it to supply electrical motors, actuators, loads requiring high startup currents, general

inductive loads (relays, solenoids) then you will remove one of AvioGuards primary reasons for its existence.

There is no hard rule as to what to supply and how – this needs to be decided on a per-application bases, tested and verified for suitability as needed.

In some cases it may be desirable to use more than one AvioGuard in a system. For example, you may want one system to supply sensitive avionics, another perhaps for high power radios/transmitters and yet another for vital aircraft controls such as electric flap and trim motors.

Specifications

DC input voltage range:	9V to 36V
DC output voltage:	12V, 12.6V, 13.2V, 13.8V (model dependent, 13.8V is standard). Note: 13.8V model outputs about 13.6V. Please see notes on backup battery use for reason.
DC output current:	0-6A continuous. 8A peak (short duration). 10A maximum (over current protection limit)
Line regulation:	0.05%
Load regulation:	0.05%
No load DC input current:	0.2A (12V DC input)
Power conversion efficiency:	Up to 90%
Start up minimum voltage:	9.0V
Undervoltage shutdown:	8.0V
Input overvoltage shutdown:	37.0V (input protected in addition by 43V transorbs)
Output short circuit current:	250mA (input current with output shorted)
Output reverse current:	<1mA (No input voltage, 12V applied on output)
Isolation voltage:	750 volts minimum (to housing, input to output)
Maximum, direct capacitive loading:	4700 uF (worst case, capacitor with load that completely discharges the capacitor during short circuit restart time).
Input capacitance:	470uF

Protection limits

The Avioguard converter applies the following protection mechanisms and limits:

Output short circuit

Current limit at 10.0A, method: hiccup autorestart, remove overload for recovery.

This method of short circuit protection prevents high current flows and secondary damage by limiting the average input current of the device to just 250mA. The converter will periodically

attempt to restart, if the restart hits the current limit, the converter shuts down again and briefly pauses to repeat the cycle.

Output Overvoltage protection

The output permits load sharing with other DC sources. The converter is designed however to shut down if the output voltage reaches 14.4V. It will restart if the output voltage falls below this limit.

Input Overvoltage protection

The converter is designed to shut down if an input voltage of 37V is reached. Two high current transorb clamping diodes will start conducting at this voltage as well and hard clamp the input to a limit of 43V.

It is mandatory to install an inline fuse or overcurrent protection device of 15A rating in the supply line to the converter. Should the overvoltage condition last for a prolonged time, the installation must be designed to interrupt supply to the converter by suitable means. Traditionally, this would take the form of a 15A circuit breaker or electronic equivalent.

Input reverse polarity protection

The converter is protected against reverse polarity by means of multiple path current shunting. Prolonged reverse polarity condition relies on an external fuse or circuit breaker to interrupt the supply to the converter. This is mandatory.

Thermal protection

The active component in the DC to DC converter will shutdown if 120 degrees Celsius is reached. This corresponds to the hottest item in the converter. This condition will occur on prolonged overcurrent (current above 6A but below the short circuit limit of 10A) depending on ambient temperature. The duration of permissible over current is directly related to the ambient temperature. As design guide, at a temperature of 20 degrees ambient Celsius, a current of 10A can be extracted for at least 1 minute (this condition assumes that before the 10A current has been applied the converter has been operating at or below continuous current rating).

Thermal shutdown will cause a restart once temperature has dropped to safe levels.

Battery backup solution

One of the advantages of the Avioguard system is a very simple and effective battery backup solution involving a small, sealed lead acid battery as used commonly in the industry.

The battery is simply wired to the Avioguard output via a panel switch allowing to isolate the battery. When the battery is switched in circuit, the Avioguard will charge the battery and keep it maintained at full charge level (requires the standard 13.8V output Avioguard).

Should input power fail during flight, the backup battery is already in circuit and seamlessly takes over the supply of the avionics. There is no power and voltage loss due to the need to use diodes.

A system using this form of battery backup is also able to increase peak power draw as the battery can assist the converter for short, high current demands.

A typical, suitable backup battery is a 12V - 7AH lead acid battery. The battery must be switched into the circuit with input supply available before flight commences. Please check and include the maximum charge current of the battery in the design of your system. A flat battery may require a large current for a short term before settling to a normal charge.

The 13.8V version is designed to output about 13.6V DC. This is a more suitable prolonged charge voltage for most sealed lead acid batteries to avoid gassing at ambient temperatures of around 25 degrees Celsius or higher for standby use. 13.6V is suitable for battery temperatures up to 40 degrees Celsius. This ensures maximum battery life at a high, maintained charge state.

This image shows a simplified battery backup scheme, please view chapter on battery backup at end of this document. This scheme can be used if it is guaranteed that the battery charge current plus load current will never exceed the current capability of the AvioGuard.

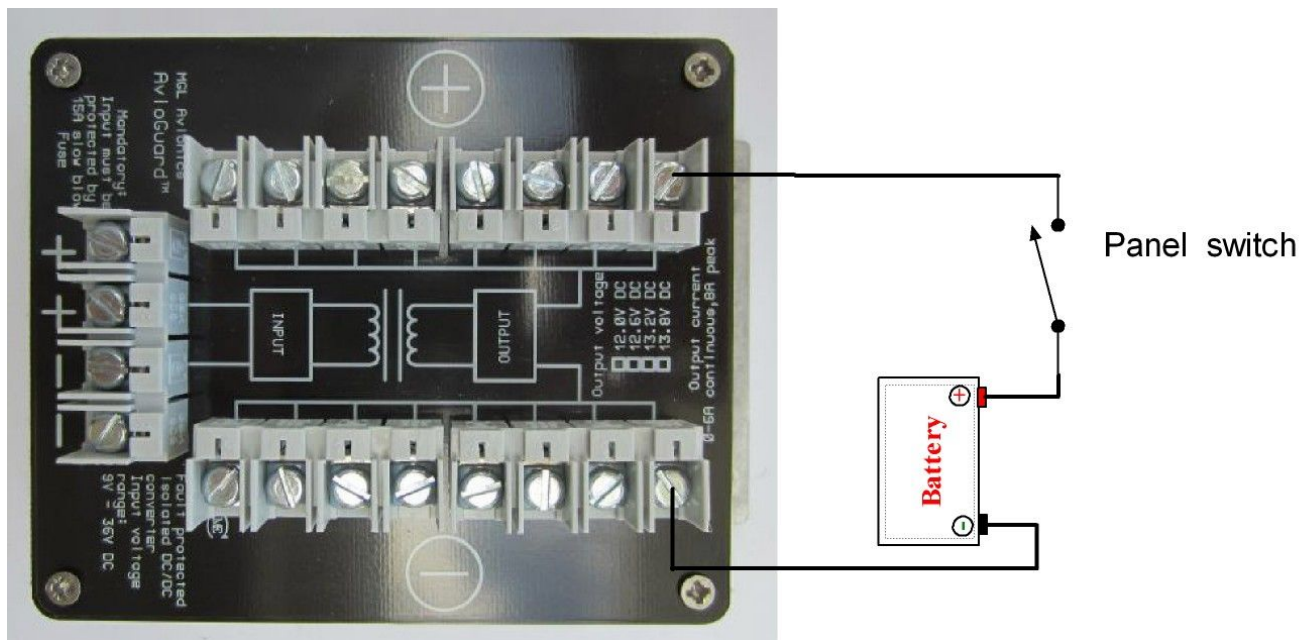

Power supply redundancy

The inherent isolation of the AvioGuard makes it very suitable for redundant power supplies. It is easily possible to simply join the output rails (+) and (-) of two AvioGuard systems. Output power will be supplied by one of the AvioGuards in case the power input to the other system fails.

Using AvioGuards means that there is no voltage drop and power loss related to using diodes and no break in the supply caused by switching systems.

Note: Multiple AvioGuards must not be connected in parallel with the intention of raising output current capability beyond the published limits for one AvioGuard system.

Mechanical

AvioGuard is housed in a solid, uniform cast aluminium housing. The plate containing the connectors is made from a 1.6mm glass fiber sheet and is covered on both sides with a solid copper layer which are electrically connected to each other and connected to the aluminium housing. This provides an effective shield of the internal circuitry eliminating EMI and preventing effects caused by strong external fields.

Conducted EMI is filtered by means of capacitors on both input and output terminals.

There is no electrical connection between either input or output terminals to the housing.

It is recommended (but not required) that the housing is connected to the airframe which is usually connected to the negative terminal of the main aircraft battery. Ordinary mounting of the AvioGuard onto bulkhead or airframe members will establish this electrical connection.

150 x 100 x 44 mm (including connectors and mounting flanges).

Flanges are 80 x 14 x 2.5 mm.

Mounting holes are 5 mm diameter (4 holes, two in each flange).

Hole spacing is 137 x 60 mm, symmetrical.



Connector specification:

10A nominal DC current rating (each terminal). Terminal construction provides for a press-fit connection using a spring loaded plate.

The connection is well suited for either bare wires or standard automotive fork terminals.

It is recommended that once installation is completed and all connections are secure, that the screws in unused terminals are also tightened. Further to this a small amount of silicon adhesive or low strength lock tight may be applied to secure the screw to prevent it from

loosening.

DO-160 applicability and guide

DO-160 prescribes the environmental classification of an electrical item installed in an aircraft.

The AvioGuard itself fulfills the requirements of DO-160D at a high level. For this purpose we concentrate on the power input supply requirements (section 16).

AvioGuard complies with Category A, B and Z (14V and 28V). This implies systems with or without a floating battery on the DC bus.

Effectively, AvioGuard provides DO-160 section 16 compliance to devices that otherwise would not be able to pass the requirements.

This applies to surge voltage, under voltage and abnormal voltage.

Installation of the AvioGuard does not prevent power loss at the equipment if input power falls below 8V (the under voltage lockout). DO-160 calls for a minimum of 10V.

The equipment will not be exposed to under voltage operating conditions (also referred to as “brown out”) as the output voltage is either at nominal voltage or switched off.

Equipment must still in itself comply with the momentary power interruptions requirement (200mS) as prescribed in section 16.5.2.3.

Thermal requirements

Ensure that installation of the AvioGuard is not compromised by high ambient temperatures. AvioGuard will not be able to sustain rated current at very high ambient temperatures and the built in temperature protection system may switch the AvioGuard off to prevent possible damage.

The aluminum housing acts as heat sink – ensure good thermal coupling to a metal airframe member to assist if needed.

Avoid installation behind cockpit panels that are not suitably ventilated. Temperatures behind panels can raise to very high levels due to heat radiated from equipment as well as environmental effects (sunlight on a dash in summer).

Before flight

Verify correct operation of all equipment supplied by the AvioGuard system. Measure total current draw from the AvioGuard system and verify that this is at or below 6A with all connected equipment at maximum current draw (for transceivers this is typically achieved during transmit).

Ensure that AvioGuard will sustain required DC supply current in all possible, expected operating conditions, including elevated temperatures.

Ensure/test this before first flight and post and enter this into the aircraft frame logbook as may be required by regulations.

Prevention of static discharge, electrical potential leveling

Avioguard is a fully isolated power supply design. This means there is no electrical conductivity between input and output.

In typical aircraft installations, the requirement still exists that all avionics be grounded to the airframe (usually this is achieved via the negative supply (battery minus)).

It is recommended that in aircraft installations utilizing the AvioGuard device a 10.000 ohm resistor is fitted between the input and output grounds. This resistor will prevent the output from floating to undesirable voltage levels relative to the aircraft's power rails while still maintaining one of AvioGuards purposes – protection against ground faults.

Failure to install this resistor without there being another electrical path to ensure potential leveling may lead to the output voltage rail floating to several thousand volts relative to the input potential. This may lead to a static discharge (electrical arc) which is not desirable in an aircraft and may cause damage to systems or trigger a fire.

The AvioGuard kit contains a 1/4W 10.000 ohm resistor intended for this purpose. The following image shows an example use of this resistor.

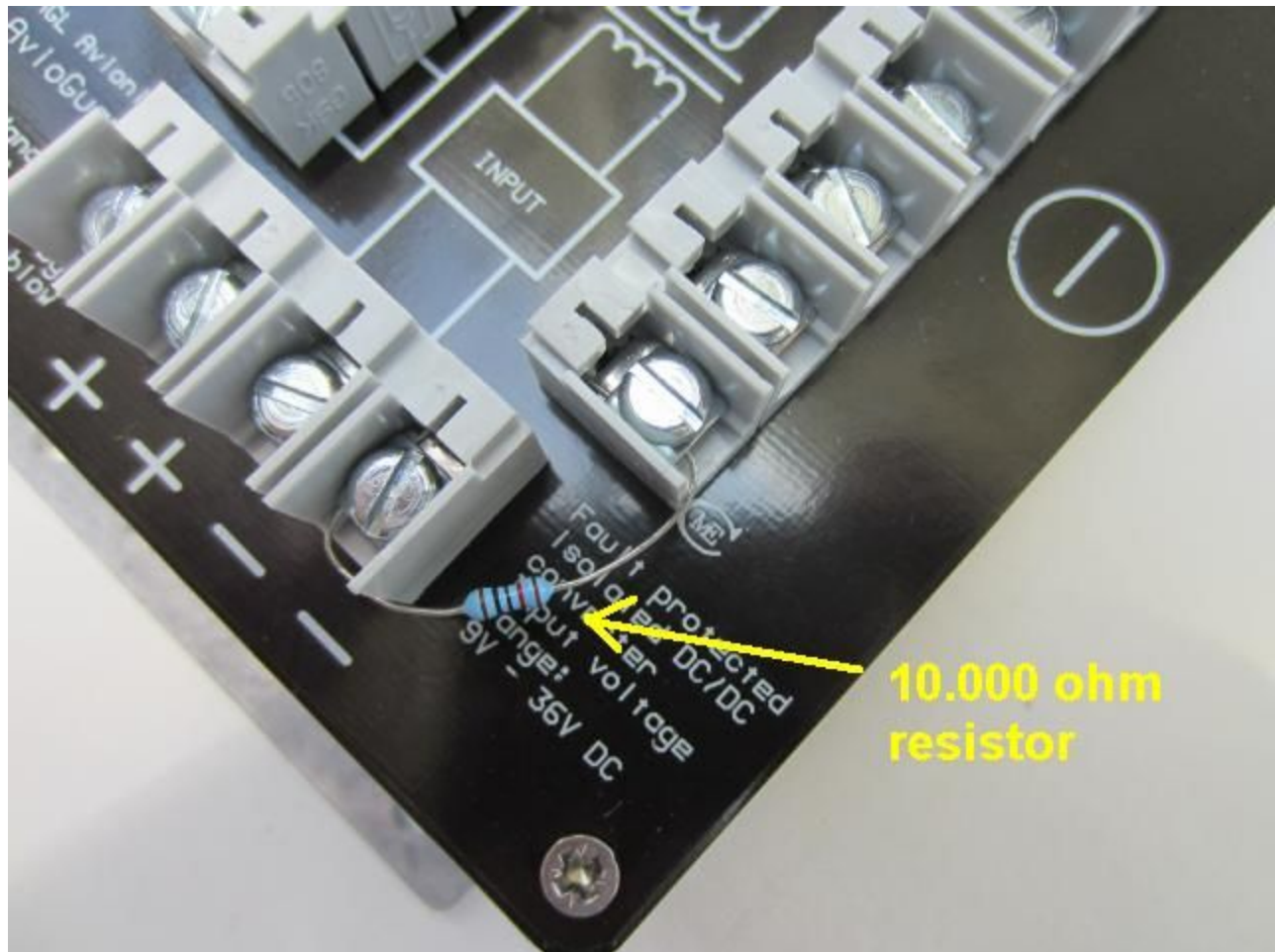

Please note that typical avionics installations may have additional electrical paths to the airframe or ground, for example, antenna grounds. It is however still recommend to install this resistor in case the antenna or other grounds are disconnected.

Battery backup solution suggestion

Various battery backup schemes may be utilized. The Avioguard, due to its regulated output is particularly suited to charge a sealed lead acid (gel) battery to full capacity regardless of actual system supply voltage.

This chapter discusses a possible solution using a sealed lead acid (gel) battery.

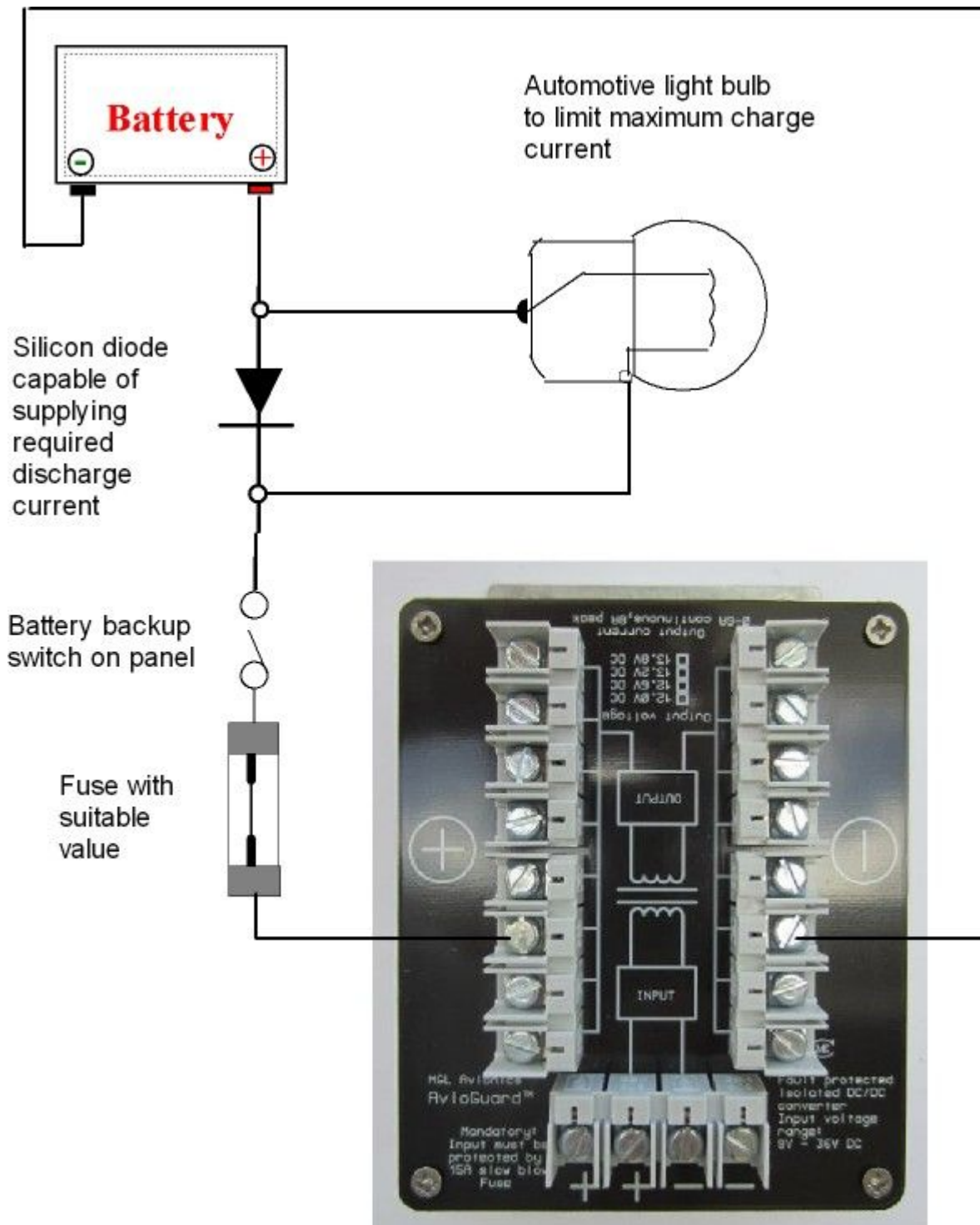

The Avioguard will shut down if an output current of about 10A is exceeded (ultimate load) or internal temperature is too high caused by longer term excessive current draw.

If the battery is not charged, it's current demands may be high and this can easily exceed the output capability of the Avioguard that also needs to supply the avionics.

This means some form of charge current limiter is needed. The simplest form of such a limiter is a 12V automotive light bulb. A filament light bulb has a low resistance when it is not lit (current is small) but a high resistance when the bulbs operating current is reached (light is on). This is ideal for our purposes.

Typical filament bulbs have a cold resistance about 1/15th that of a fully lit (hot) bulb. A typical 12V/3W lightbulb has a "hot" resistance of about 48 ohms but less than 4 ohms when cold. This limits the maximum charge current possible with a completely flat battery to only 0.25A, allowing it to increase as the battery charge voltage increases and the bulb extinguishes.

During discharge, we need to "shunt" the bulb so it does not form an undesirable resistance in line with the load we are supplying. A simple diode does this nicely.

Ensure the diode is capable of conducting the required current. We recommend that a 10A silicon or shottky diode we used. The shottky type results in less voltage drop (0.4V typical) while a silicon diode drops around 0.7V.

It is recommended that a suitable fuse be installed in series as well to prevent battery overload in the case of a load short circuit.

A panel mount switch is available to the pilot so he is in control of the backup system.

During pre-flight, the battery backup switch is turned on with main power off and the avionics should start up, supplied by the battery. At this stage the charge condition (voltage) may be observed.

The switch remains on throughout the flight allowing the battery to charge and as it is in the circuit, backup power is available without interruption should main power fail.

It should be quite acceptable to replace the fuse and switch with a typical manually operated circuit breaker with a suitable trip current rating (for example 10A).

A recommended capacity battery is a 7AH sealed, gel type lead acid battery. A fully charged battery in good condition will be able to supply 7A of current for up to one hour.

Note:

It is recommended that the final solution implemented be fully tested using a completely discharged battery. Safety and correctness of operation of the system must be verified. Observe that backup behavior and battery charge rates are suitable for the application.