

ENGING TACHOMETER

Illustration of Instrument Connection :

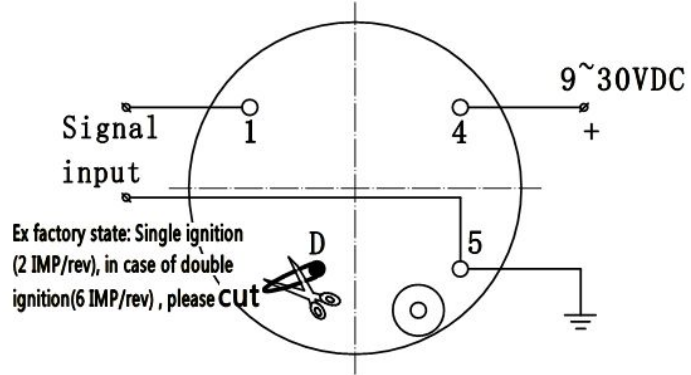

NOTE :

- 1) Installing the instrument from behind the panel, according to the size of the gauges use a 2-1/4" (57mm) hole or 3-1/8" (80mm) hole. Use 4#40 screws to hold instrument secure.
- 2) The gauge is suitable for ROTAX 582 engine, 2/6 IMP/rev. Other engines may need to be customized. Note: after cutting the wire, ensure that no touch or conduction between the two leads.
- 3) Mount at least 12" away from compass.
- 4) This unit has not been approved for type certified aircraft.
- 5) Do not connect instrument to any other power source. Damage may occur.