



Merlin Installation Manual



Alpha Systems AOA

6180 140th Ave. N.W.

Ramsey, MN 55303

Customer Support

763.506.9990

aoa@depotstar.com

The information contained in this manual is for reference only. If any information contained herein conflicts with similar information contained in the Airplane Flight Manual, the information in the Airplane Flight Manual shall take precedence.

COPYRIGHT NOTICE

© 2015, Alpha Systems AOA. All rights reserved.

Merlin

Merlin AOA Kit - DSTR-AOA-9900K
Merlin Dual AOA Kit - DSTR-AOA-9900KDUAL
Merlin Pressurized AOA Kit - DSTR-AOA-9900PK
Merlin Dual Pressurized AOA Kit - DSTR-AOA-9900DPK

INSTRUCTIONS MANUAL

P# AOA-9050-Merlin

Table of Contents

<u>Section</u>	<u>Page</u>
1. General	1.1
1.1 Objective	1.1
1.2 Background Information by the Numbers.....	1.1
1.3 Disclaimers	1.1
1.4 Page and Subject Numbers	1.2
1.5 Revisions	1.2
1.6 Technical Support	1.2
1.7 Warranty Information	1.2
1.8 Restrictions and Limitations.....	1.3
1.9 System Description (Non-Pressurized Standard Version)	1.4
1.10 Pressurized Version Overview	1.5
1.11 Dual Standard Version	1.6
1.12 Dual Pressurized Version.....	1.7
1.13 AOA Probe and Mounting Plate	1.8
1.14 AOA Interface Module (IM) Description and Operation.....	1.10
1.15 Pressurized Interface Modules	1.11
1.16 Display Overview.....	1.13
1.17 Display Mounting Kits	1.15
2. Planning	2.1
2.1 Preparation	2.1
2.2 Establish the Location for the Angle of Attack.....	2.1
2.3 Establish the Desired Location for the AOA Interface Module	2.2
2.4 Establish the Location for the AOA probe	2.3
2.5 Establish a Plan to Route the Sense Lines Through the Aircraft	2.4
2.6 Establish a Plan for the Electrical Power.....	2.4
2.7 Optional Probe Heat Installation	2.5
2.8 Review Your Plans.....	2.5
3. Installation	3.1
3.1 Preparing to Install the Probe	3.1
3.2 Installation of the AOA Sense Lines	3.2
3.3 Install Wiring, Switch & Circuit Breaker For the AOA System.....	3.2
3.4 Install Wiring, Switch & Circuit Breaker for Probe Heat	3.3
3.5 Install the AOA Indicator	3.4
3.6 Install the AOA Interface Module (IM).....	3.5
3.7 Install the AOA Probe and Mounting Plate.....	3.7
3.8 Correct Position of Probe Lock Plate	3.8
3.9 Inspect the AOA Installation	3.9
4. Documentation	4.1
4.1 Background Information	4.1
4.2 Major vs. Minor Alteration	4.1
4.3 Logbook Entries.....	4.2
4.4 Documentation Review	4.6
5. Appendix	5.1
5.1 Acronyms and Abbreviations	5.1
5.2 Operational and Environmental Limitations.....	5.2
5.3 Diagrams.....	5.3

1. GENERAL

1.1 Objective:

There is a lot of information contained in this manual that is repeated in different ways to help explain all steps of installation through calibration and help with the FAA required paperwork. This manual is designed to take you step-by-step through the planning, installation, documentation and calibration for your Alpha Systems Angle of Attack System. If you follow the instructions throughout the entire process, the installation can be completed correctly the first time.

This manual is intended to describe and guide the installation process of a standard AOA system. However, differences will be outlined to cover a variety of AOA system versions such as: pressurized, dual, and dual pressurized systems.

1.2 Background Information by the Numbers:

AC23.1309-1C has a stated objective ***“to improve the safety of the airplane fleet by fostering the incorporation of both new technologies that address pilot – error and weather related accidents and those technologies that can be certified affordably”***.

14 CFR part §21.93a states in part ***“a minor change is one that has no appreciable effect on the weight, balance, structural strength, reliability, operational characteristics or other characteristics affecting the airworthiness of the product”***.

14 CFR part §43.13(b) states in part ***“each person altering an aircraft shall do that work in such a manner and use materials of such a quality, that the condition of the aircraft worked on will be at least equal to its original or properly altered condition”***.

What does all this mean?

- The FAA is encouraging modifications that improve operational safety. The Alpha Systems Angle of Attack System is considered to be such a modification.
- A determination needs to be made by the person installing the angle of attack system that it is either a major or minor installation. Alpha Systems believes that installing its angle of attack system in most aircraft is a minor alteration; however this determination is ultimately the responsibility of the person performing the alteration and returning the aircraft to service.
- Alpha Systems believes that installing its angle of attack system in most aircraft meets the requirements of 14 CFR §43.13(b) if done in accordance with this installation manual, AC43.13-1B, AC43.13-2B and AC23.1309-1D. Again this determination is ultimately the responsibility of the person performing the alteration and returning the aircraft to service.

1.3 Disclaimers:

Alpha Systems Angle of Attack System will perform well in a large variety of aircraft. For this reason the instructions were written in a general format that will work for most aircraft. We understand that the referenced regulations and advisory circulars may not be applicable to all aircraft; however we feel that they offer excellent guidance for this installation and should be followed.

1.4 Page and Subject Numbers:

Pages in this manual are assigned a two part page number. The first number always specifies the chapter number. The last number always indicates the page number. Subjects within a chapter will be numbered with the chapter number followed by the subject number.

1.5 Revisions:

When a revision is required of this manual the manual will be revised in its entirety.

1.6 Technical Support:

Phone:
763-506-9990

E-mail
aoa@depotstar.com

1.7 Warranty Information:

LIMITATION OF REMEDIES AND LIABILITY: If this Alpha Systems AOA product is proved to be defective, **THE EXCLUSIVE REMEDY OF ALPHA SYSTEM AOA's / DepotStar, Inc. OPTION SHALL BE TO REPAIR OR REPLACE THE DEFECTIVE COMPONENT ONLY.** Alpha System AOA / DepotStar, Inc. shall not otherwise be liable for installation or removal costs or any other losses or damages, whether direct, indirect, special, incidental or consequential, regardless of the legal theory asserted, including negligence, warranty or strict liability. **If you cannot accept these terms, return the uninstalled unit along with the receipt for a refund.**

Included in the documentation package is the **Warranty Registration Form**. This form **must** be completed, signed and returned to Alpha Systems AOA / DepotStar, Inc. to activate the product warranty.

1.8 Restrictions and Limitations:

- This AOA system has not been determined to be suitable for installation in any specific aircraft by Alpha Systems. It may be installed in a type-certificated aircraft, provided that it has been determined suitable for installation by an appropriately rated mechanic by means such as field approval or as a minor alteration.
- Installation of the Alpha Systems AOA in a commuter or transport category airplane is prohibited, unless approval is given from the FAA.
- Installation of the Alpha Systems AOA as a replacement for or modification to an existing approved stall warning system is prohibited!
- The Alpha Systems AOA is required to have a placard located in plain view that must state the following: “Not for use as a primary instrument for flight.”
- The AOA system may not be used as a substitution for the certified aircraft stall warning system.
- No operational credit may be taken for such items as reduced approach speed and shorter landing distances.
- The Alpha Systems AOA is not required and is intended to provide supplemental information to the pilot.

The Alpha Systems AOA cannot be placed in the cockpit in such a manner as to interfere with the pilot’s view of primary flight instruments.

The Alpha Systems AOA cannot be placed in the cockpit in such a manner as to obstruct the pilot’s view or cause distraction.

The Alpha Systems AOA is a stand-alone system and does not replace any existing, primary instruments, or displays and is not considered essential for flight.

1.9 System Description (Non-Pressurized Standard Version):

The Alpha Systems AOA measures pressure at two points on an Angle of Attack (AOA) probe mounted solidly to the wing in reference to the chord of the wing, conveying changing differential pressures, via sense lines, to the system interface module (IM). The IM converts pressures into electrical signals which are then transmitted to the display. The indicator displays the appropriate segments to convey the AOA / lift information to the pilot. The IM has an output connector which allows connection to the aircraft's audio system to provide warning annunciations through the audio panel, into the pilot's headset.

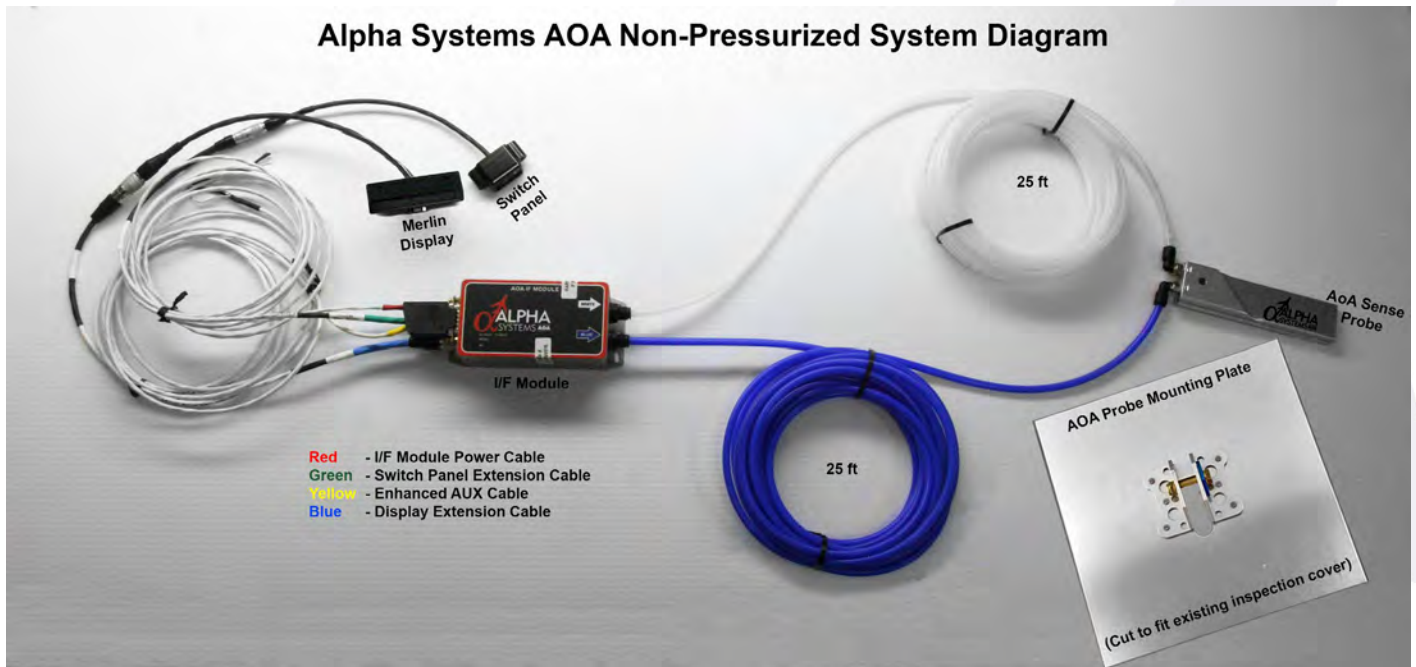

1.10 Pressurized Version Overview:

Alpha Systems' pressurized unit is designed to be installed without drilling holes or modifying the pressure vessel. This is accomplished by placing the circuitry needed for the AOA probe sensing, power supply and associated circuitry in the AOA **Sensor Interface Module** and mounting those components outside of the pressure bulkhead. The AOA probe picks up the differential pressures and sends them through two hoses directly to the **Sensor Interface Module**. One shielded cable with four wires: Power, ground, signal and shield, is routed to an existing electrical bulkhead connector. This allows a pass-through utilizing unused pins on the existing connector. On the inside of the pressure vessel or inside of the pressurized cabin, match up the same electrical pins and solder the same wires matching the signals from outside to inside. Use the prewired cable that will plug directly into the **IM**, mounted securely inside the cabin within 6 feet of the display location.

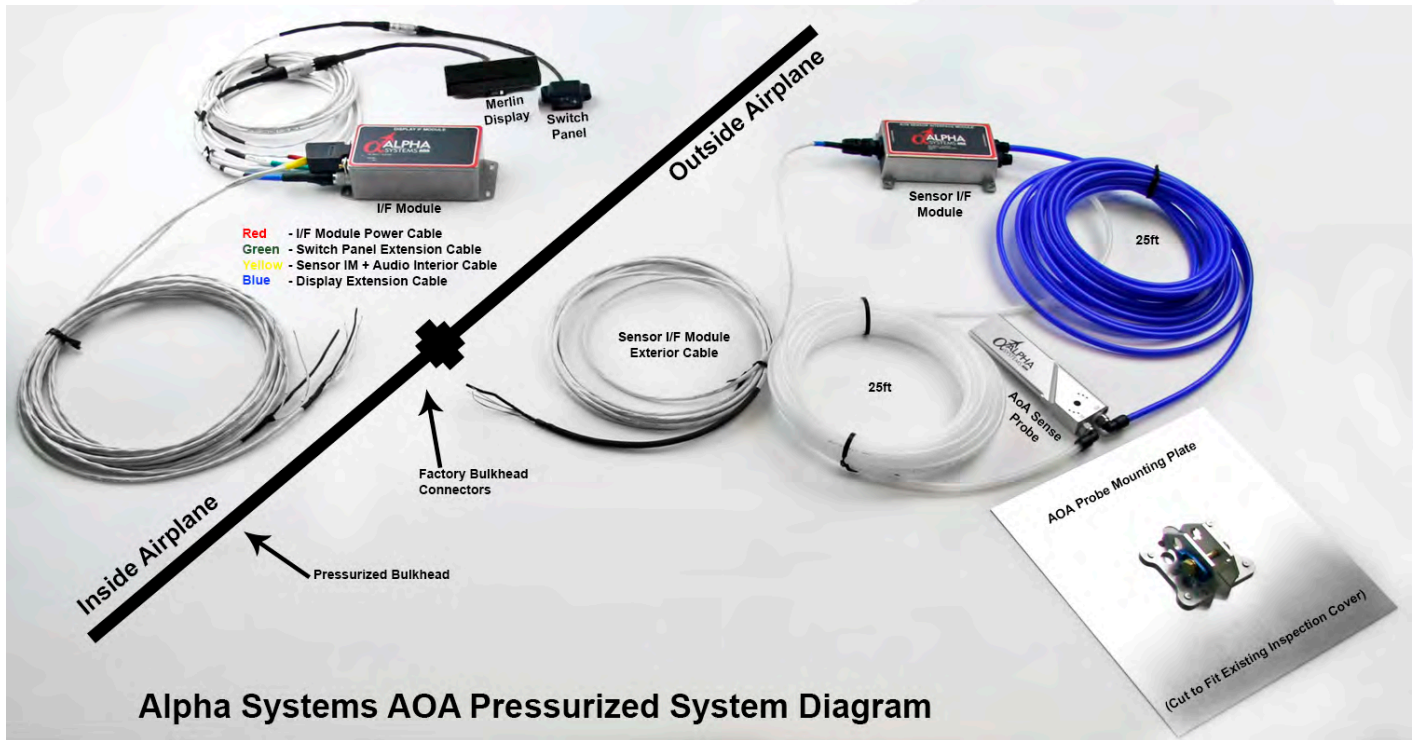

1.11 Dual Standard Version:

Alpha Systems' dual kits are designed to be installed in situations where more than one pilot would like to observe the AOA indications. This is done by installing a **Dual Display Interface** that splits the display signal from one **IM** to two displays. A dual display extension cable is used to connect the **IM** to the **Dual Display Interface**, which connects via display extension cables to each display. Note that one display will be labeled as **SECONDARY**, and must be installed with the primary display in order to function properly. The displays are calibrated simultaneously, using the same OAA & Cruise set-point calibration routine as a Non-Pressurized Standard Version. The main difference in a dual system is the Brightness Calibration routine can be completed individually for each display to each pilot's preference.



1.12 Dual Pressurized Version:

Alpha Systems' dual pressurized kits are designed to be installed in situations where more than one pilot would like to observe the AOA indications in a pressurized aircraft. A dual pressurized system utilized the components of both a dual and pressurized system, including the **Dual Display Interface** and **Sensor Interface Module**. The calibration routine, AOA observations, and overall functionality remain the same as a Non-Pressurized Standard Version. However, remember that the Brightness Calibration routine is individual to each display in any dual system.

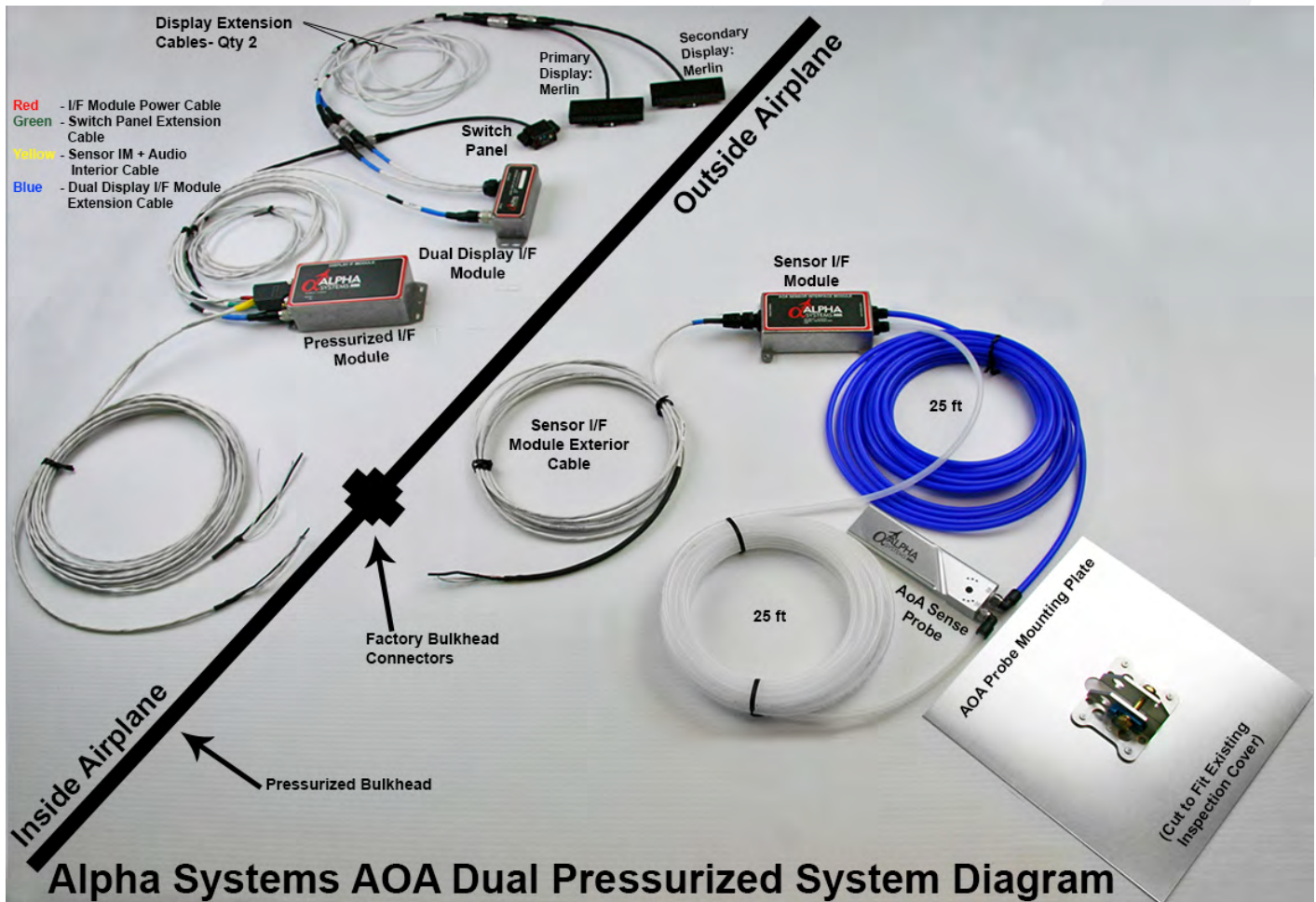

1.13 Flap IO Extension (Optional):

Alpha Systems' Flap IO Extension kit is designed to be installed in situations where the pilot would like to observe the changes AOA corresponding to different flap positions. The Flap IO Extension can be incorporated into an existing Alpha Systems AOA kit. It utilizes the aircraft's existing flap inputs to feed information through the additional **IO Module** and into the standard/pressurized **IM**, and finally to the display, providing supplemental AOA information to the pilot. The Flap IO Extension kit can be incorporated into **any** existing Alpha Systems configurations.

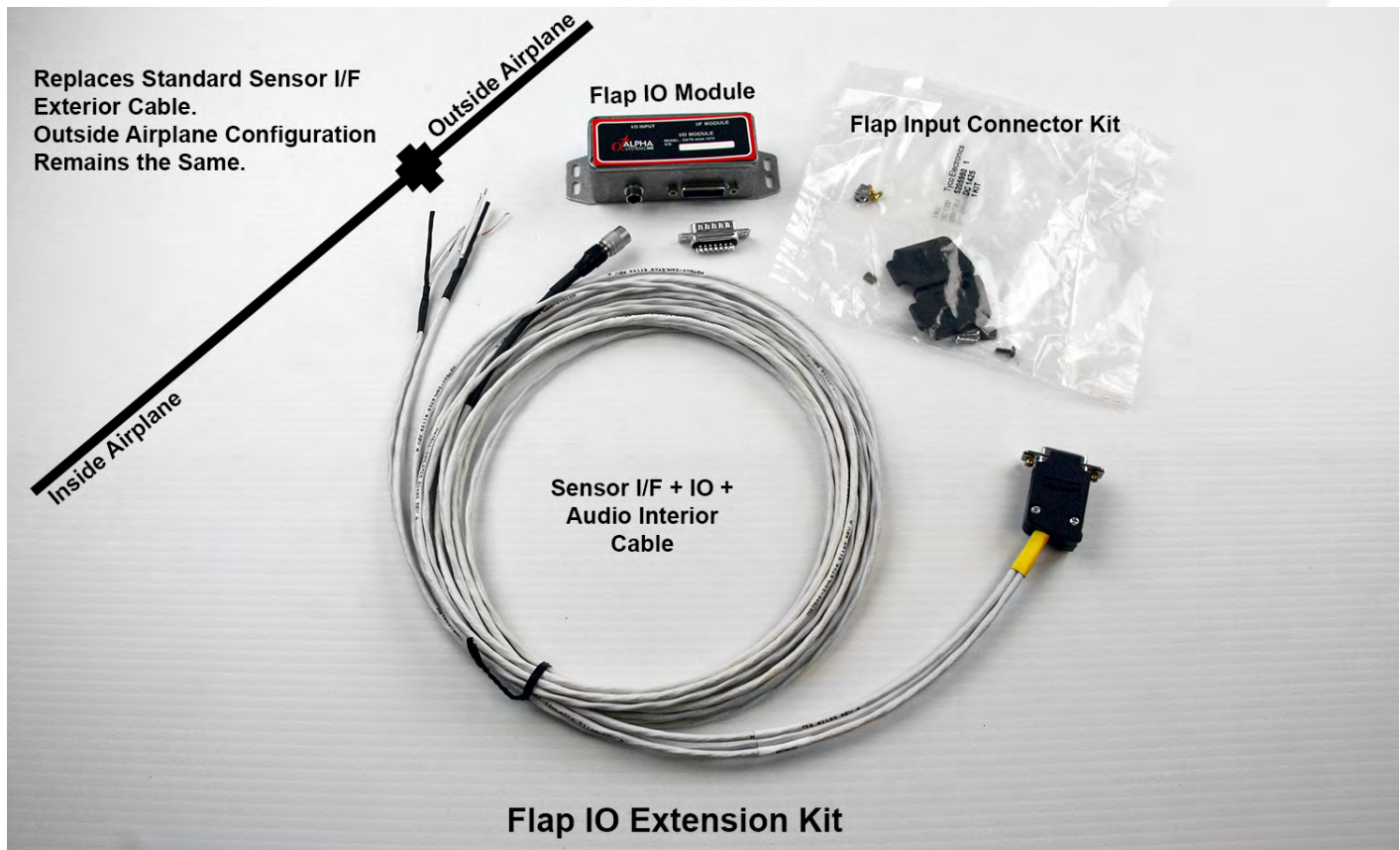

1.14 AOA Probe and Mounting Plate:

GENERIC INSTALLATION OVERVIEW

Due to the huge number of aircraft types, models and pilot installation preferences; this manual will try to address concerns so that, once installed, the system will function properly. To begin the installation process, the AOA probe must be installed in clean air (undisturbed air stream) in a location so that at all Attitudes, Slips or Skids; NOTHING could block or disrupt the air at the tip of the probe. The standard AOA probe mounting plate is 9" x 9" - cut to fit. Typically, it replaces an existing inspection cover which will then hold the AOA probe. The mounting location must be a rigid location on the aircraft, a minimum of 2 feet outside the prop arc, and typically mounted between 6" inches back from leading edge and 10 inches up from trailing edge - center span optimal. This prevents any attitude, slip or skid; NOTHING disrupting the direct air into the AOA probe. On twin engine aircraft, it could be installed on the nose of the aircraft and in an area determined by the A&P to be non-structural, such as in the nosecone or in the skin. The probe must be mounted vertically and must not be blocked by any probe or antenna. After the mounting plate and probe are attached to the aircraft, it may be necessary to remove material on the mounting plate to allow the AOA probe to be adjusted past the 50 degree angle to allow for full scale electronic calibration (if additional angle increase is required).

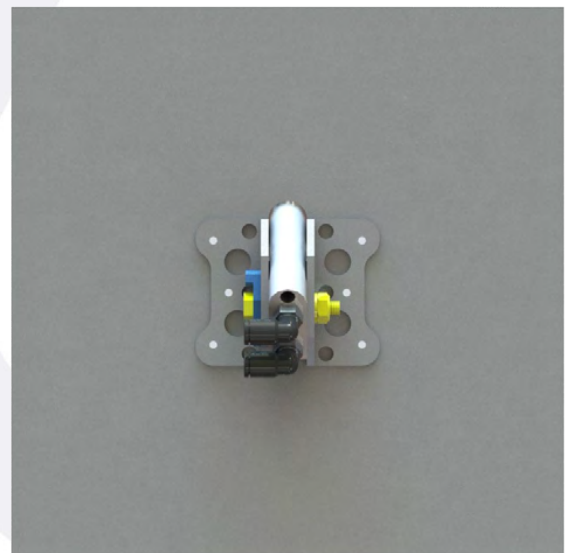
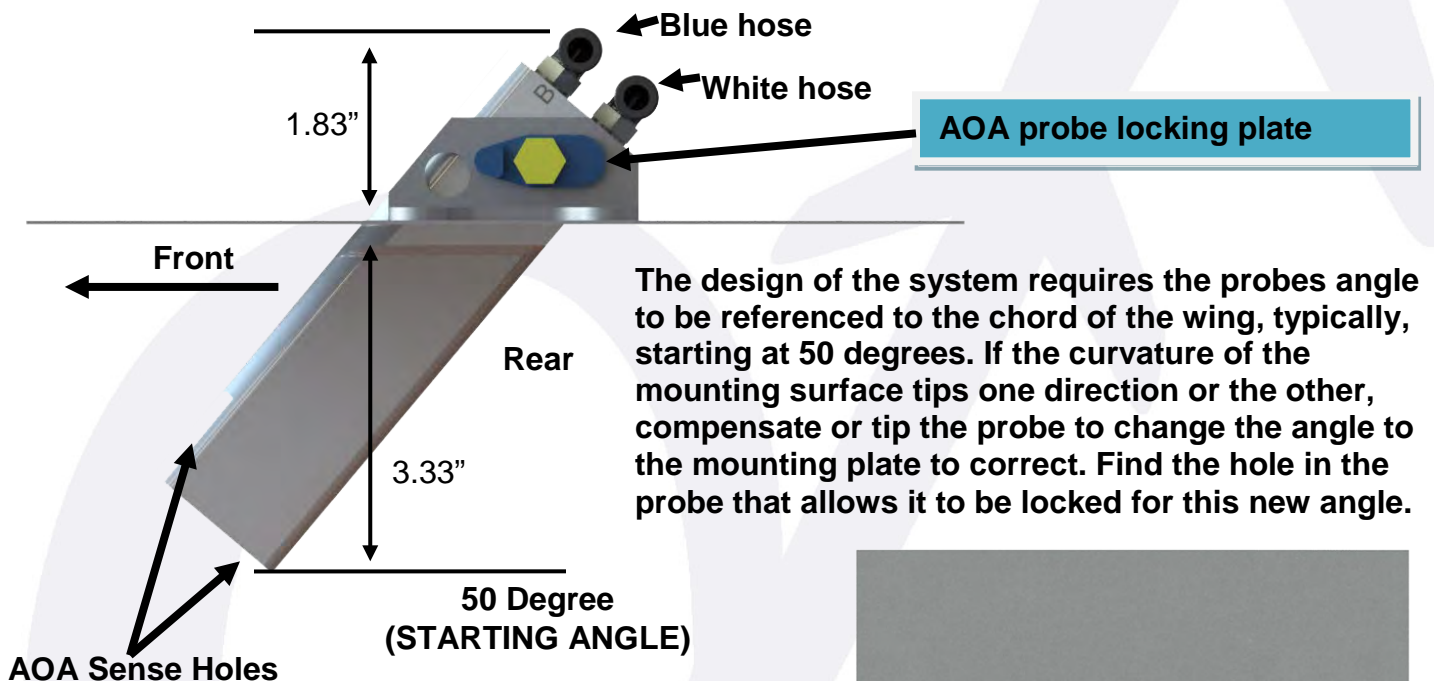

NOTES:

- 1.) Probe and 2 fittings = .23 lbs.
- 2.) 9" x 9" plate + hardware = .40 lbs. (Less when cut to fit existing opening)
- 3.) Add .25 lbs. with optional probe heat
- 4.) Weight of sense line is .02 lbs. / ft.
- 5.) Material: .040" 6061-T6 Aluminum

Mounting Plate Drawing

The mounting plate is typically cut to fit in an existing inspection panel. However, the mounting brackets can be removed by drilling out the rivets. These holes and probe slot can be transferred to an existing inspection cover, nose cone, skin, or other method of attaching the angle brackets securely to the aircraft.

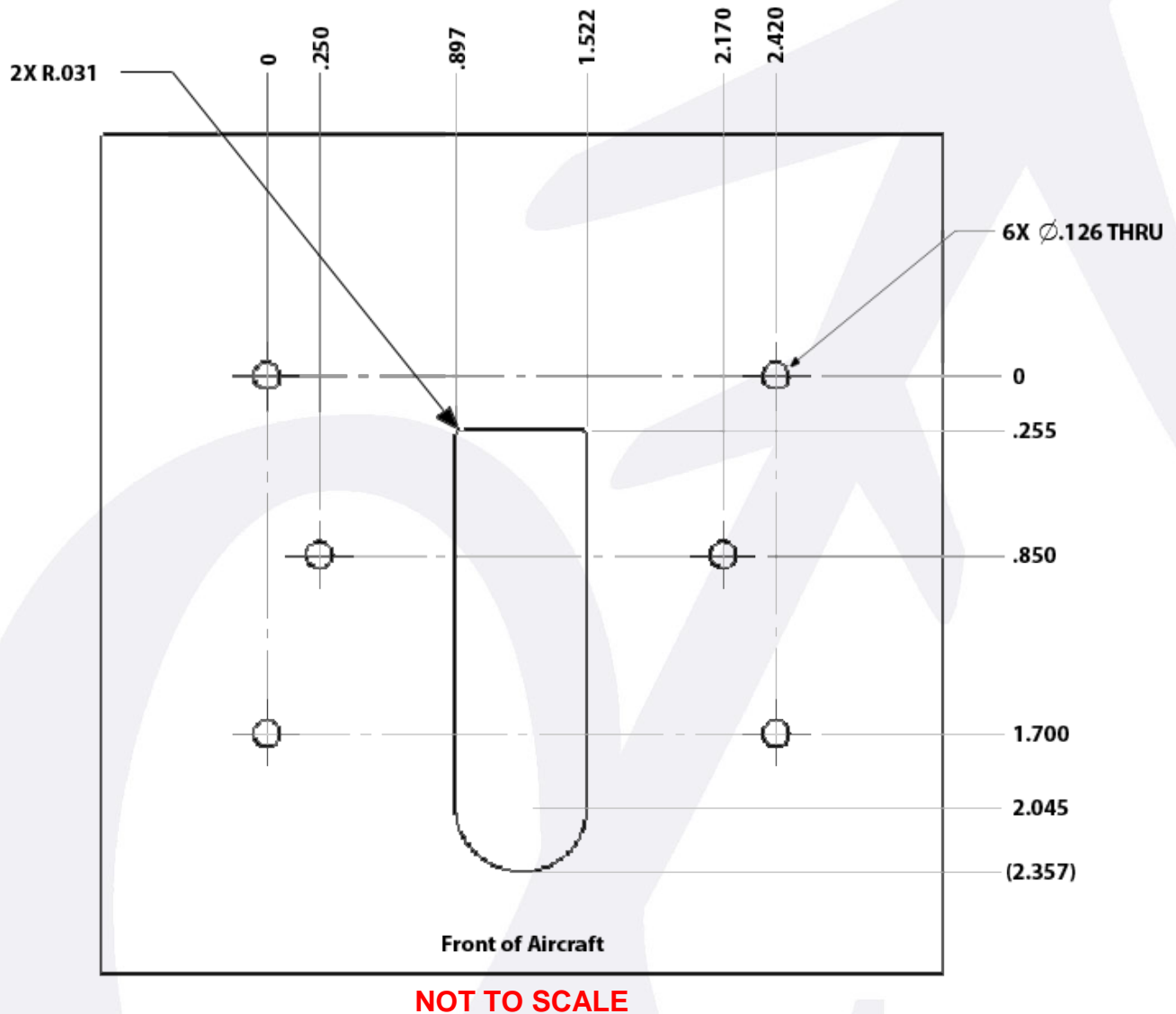

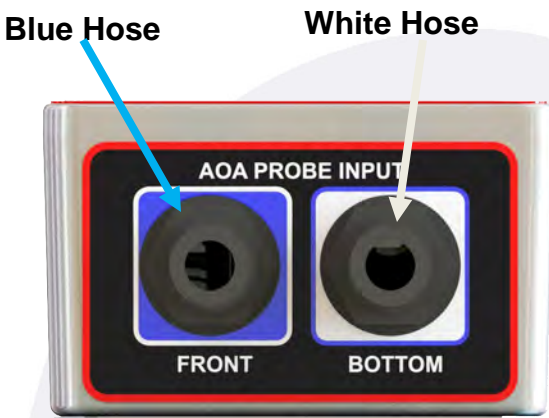
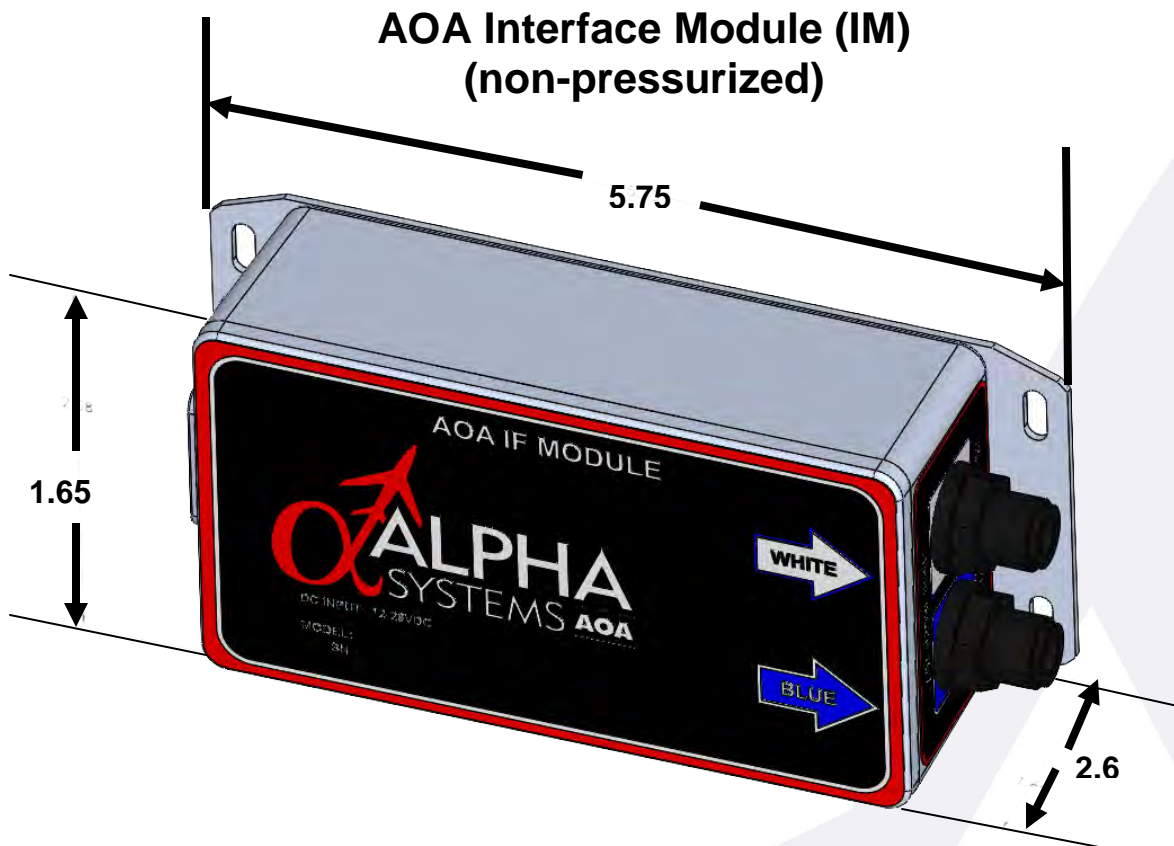

AOA Probe Sense Connectors



- 1.) Red = Power In
- 2.) Yellow = I/O Interface
- 3.) Green = Switch Panel
- 4.) Blue = Display Connector

1.15 AOA Interface Module (IM) Description and Operation:

The Alpha Systems Angle of Attack system constantly samples pressures at two points from the AOA probe and conveys those changing pressures, via sense lines, to the AOA Interface Module (IM). The IM converts those pressures into an electrical signal that's transmitted to the display. The display interprets the signal and the display conveys the angle of attack / lift information to the pilot. In addition to the visual display, the IM has an I/O port that connects to the aircraft's audio panel.

Mounting Holes for the Display Interface Module

This shows the holes for mounting the **IM** securely, anywhere inside the cabin of the aircraft. Clearance for the electrical connections, tubing and servicing should be taken into consideration for access when a location is chosen.

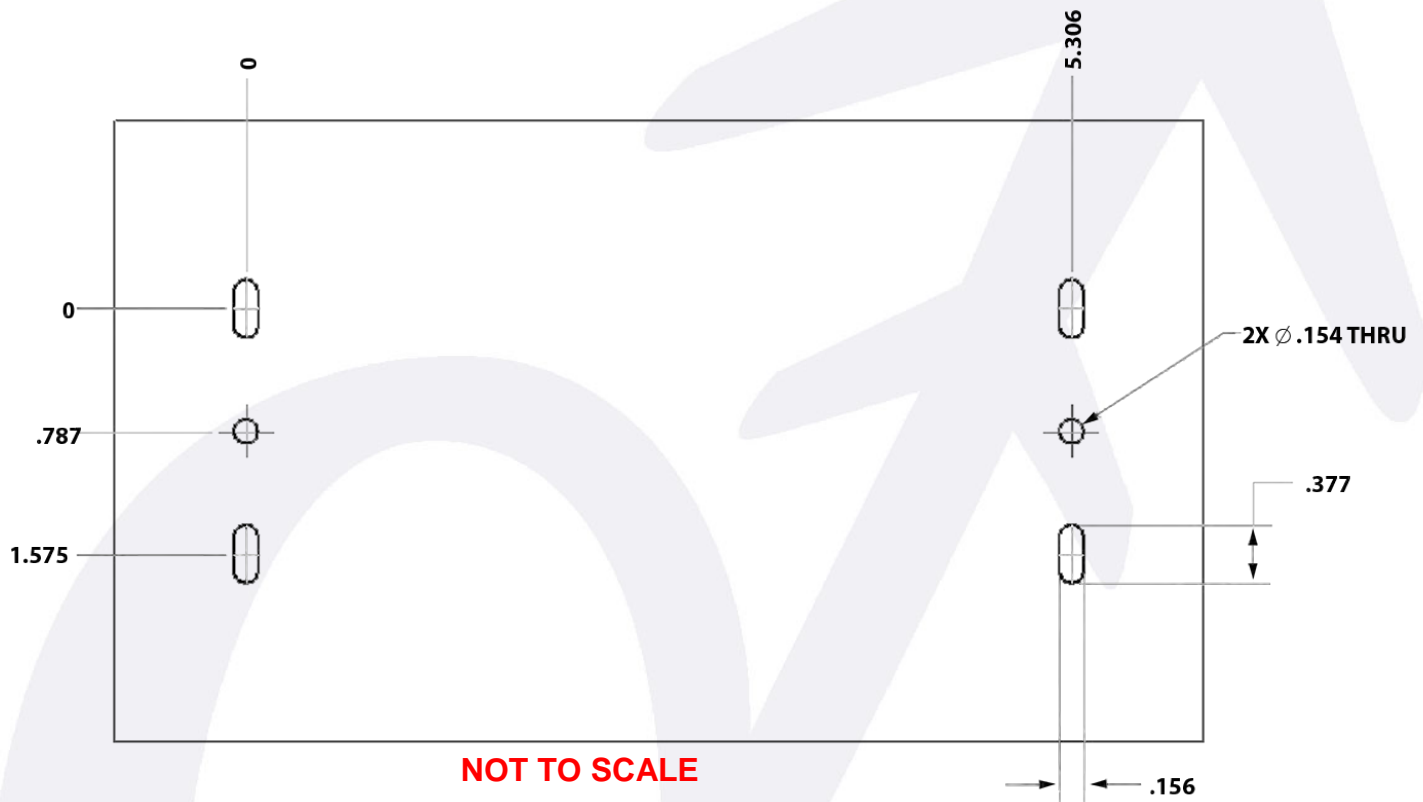

1.16 Pressurized Interface Modules:



In a pressurized system, the Alpha Systems angle of attack unit constantly samples pressures at two points from the AOA probe and conveys those changing pressures, via sense lines, to the **Sensor Interface Module**. The **Sensor Interface Module** converts those pressures into an electronic signal that's transmitted to the **IM** via an existing bulkhead connector and provided cable. From the bulkhead connector, the signal is transmitted to the **IM** via the AUX I/O connector. The **IM** then sends a digital signal to the AOA display. The display interprets the signal and turns on the appropriate segments to convey the angle of attack / lift information to the pilot.

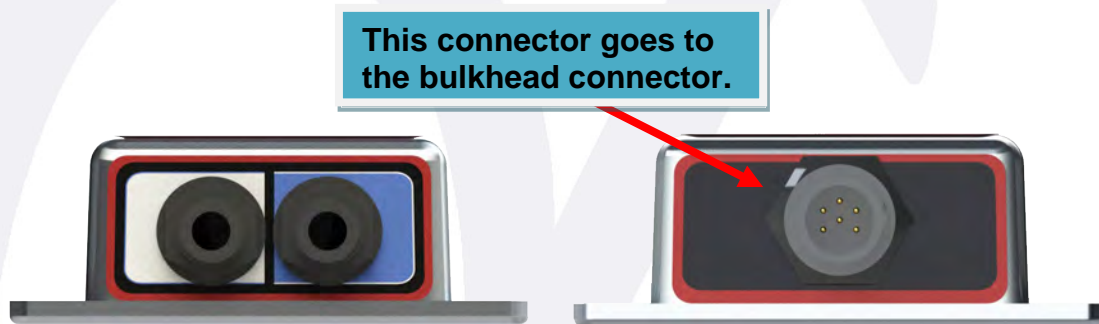

1.17 Display Overview:

Alpha Systems AOA **Merlin** is an AOA display with 16 colored LED segments and has the dimensions of 3.5" long X .810" high X 1.230" deep and weighs .300 LBS, with the extension cable. The display can be mounted anywhere in the cockpit, but it is recommended to be placed directly in front of the pilot, mounted underneath or preferably on top of the glare shield with either the solid or custom swivel mount. The swivel kit compensates for a sloping glare shield, allowing the display to be positioned to be seen in the pilots' or co-pilots' peripheral vision.

Merlin AOA Display

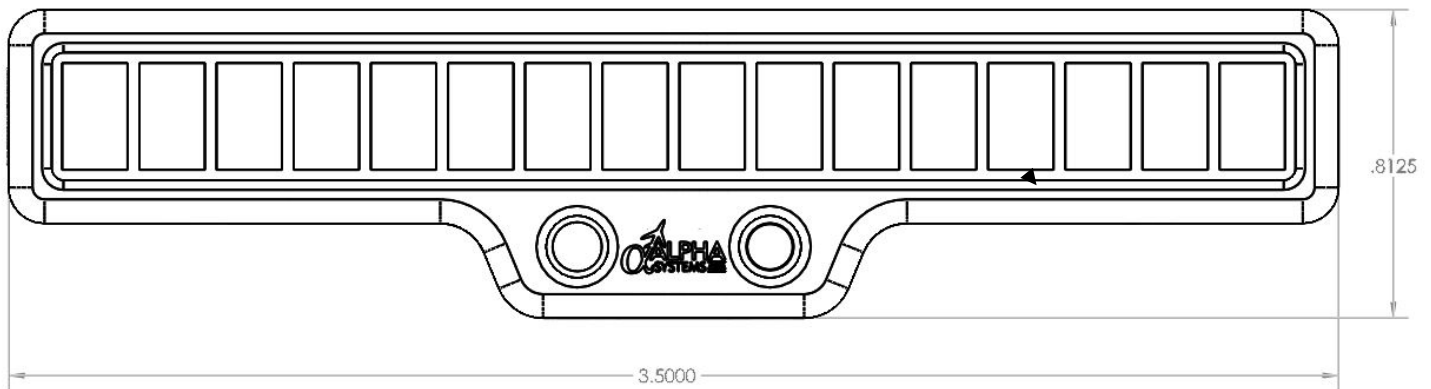
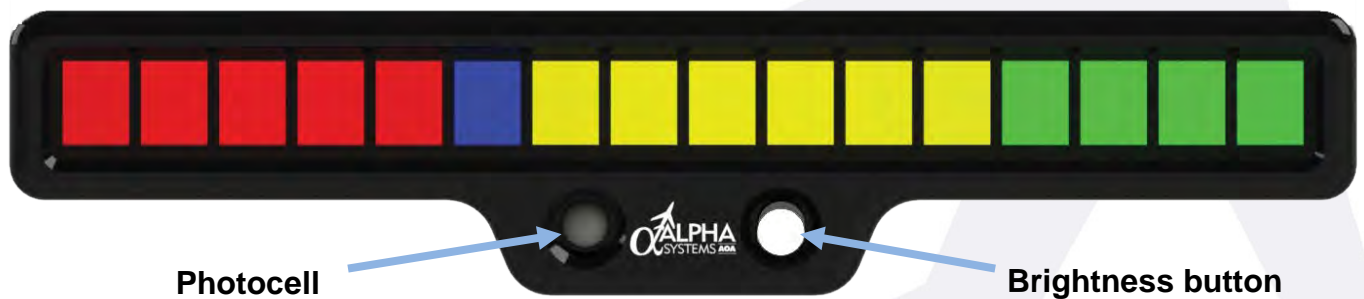

The Merlin AOA system requires the addition of a switch panel. This panel is used for calibration entries, audio mute indicator and the audio mute switch



The wide end of the slot is the position identifier.

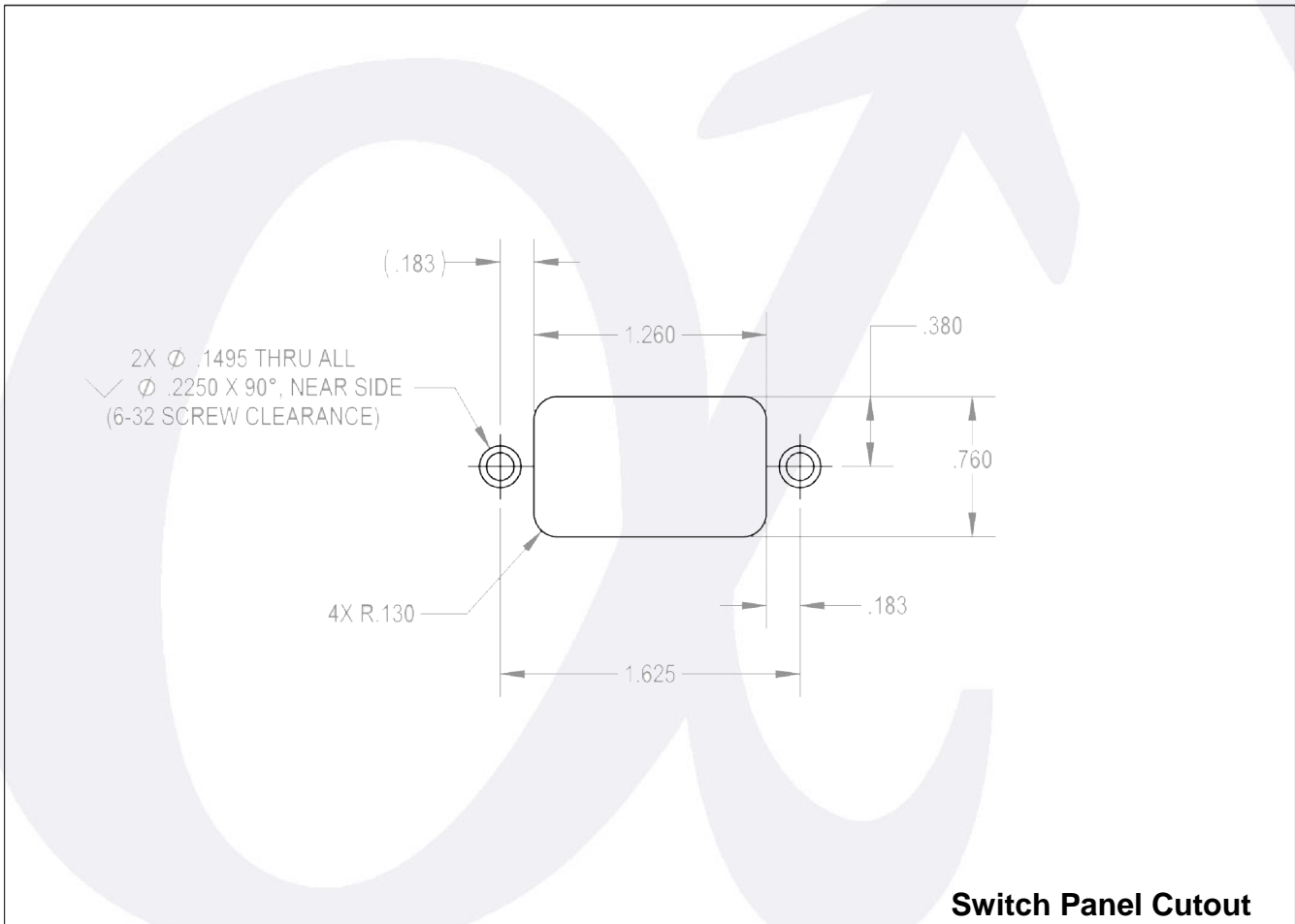

Switch Panel Cutout

NOT TO SCALE

1.18 Display Mounting Kits:

The **Merlin** AOA display can be mounted in the pilot's peripheral vision under the glare shield and can be mounted on top by purchasing either of the 2 optional mounting kits; a solid mount or swivel kit which compensates for curvature of the glare shield and accurate positioning in a horizontal orientation.

Vertical Swivel Mounting Kit

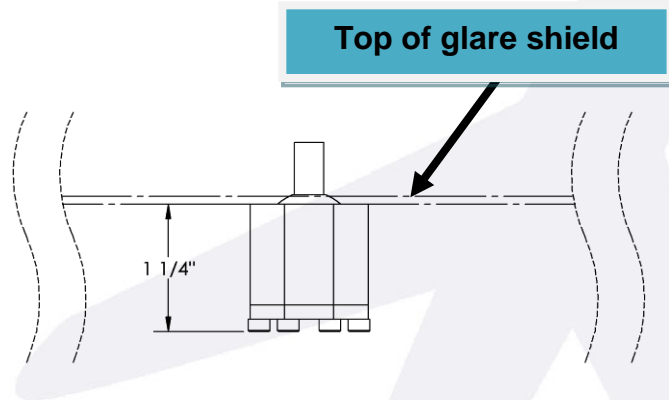
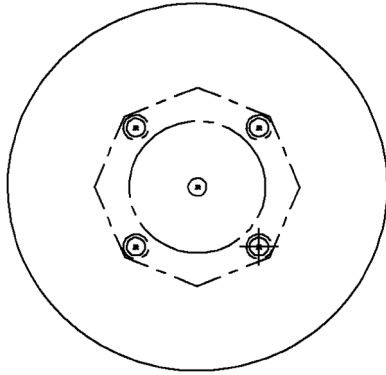

The Merlin display has mounting holes on the back, top and bottom of the case threaded for 6/32 screws

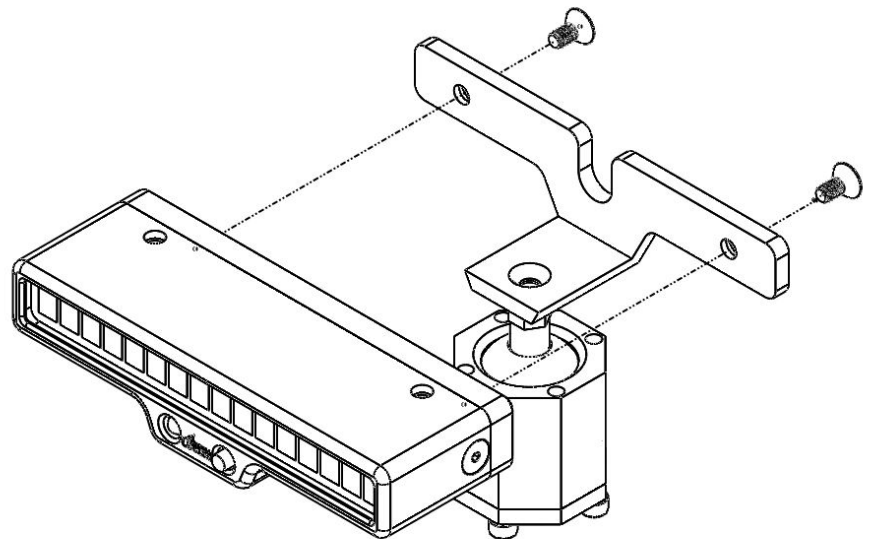
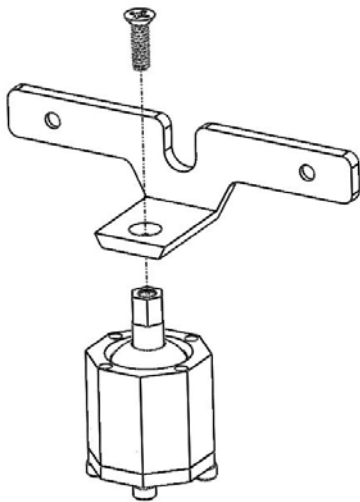

The swivel kit is mounted from under the glare shield and the shaft allows the L bracket to be mounted solidly with the provided screw

The swivel mount drill guide disk is included with the mounting kit. It's used to aid in the drilling of the mounting holes for surface placement.

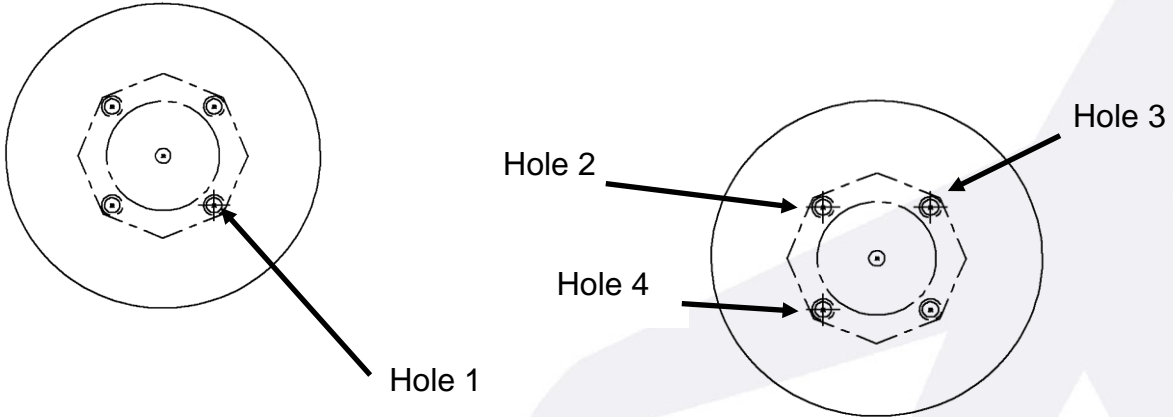

Step 1

Orient drill guide in location where swivel will mount, Using a #40 drill, drill hole, Cleco through hole, spin disk in final location.

Step 2

When disk is in the final position, drill hole 2, Cleco, drill hole 3, Cleco, drill holes 4 and 5.

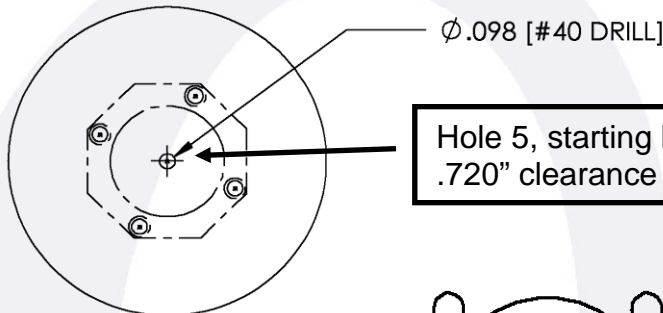

Hole 5, starting hole for .720" clearance drill.

4 Mounting holes and center clearance pattern on dash.

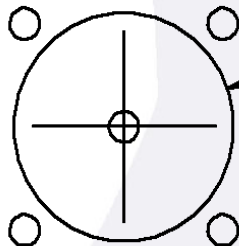

Ø .720 [23/32"]

Step 3

Using Hole 5, drill for clearance swivel base of .720".

Once the 4 outer holes are located and drilled, re-drill with a # 32 (.116") clearance for the 4-40 mounting screws.

NOT TO SCALE

Glare Shield Mounting Kit

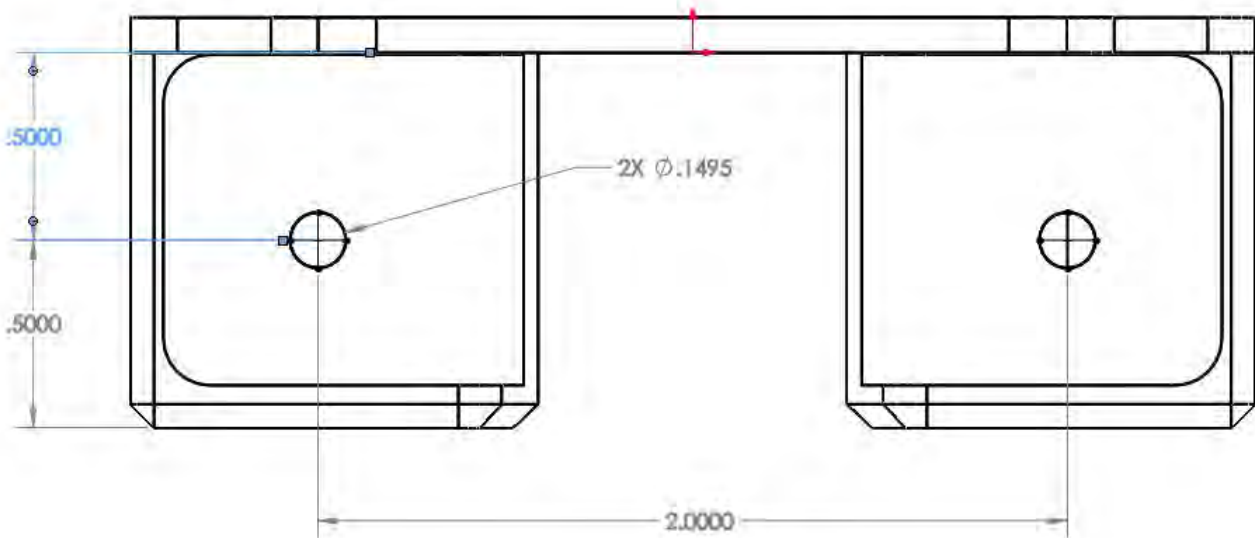
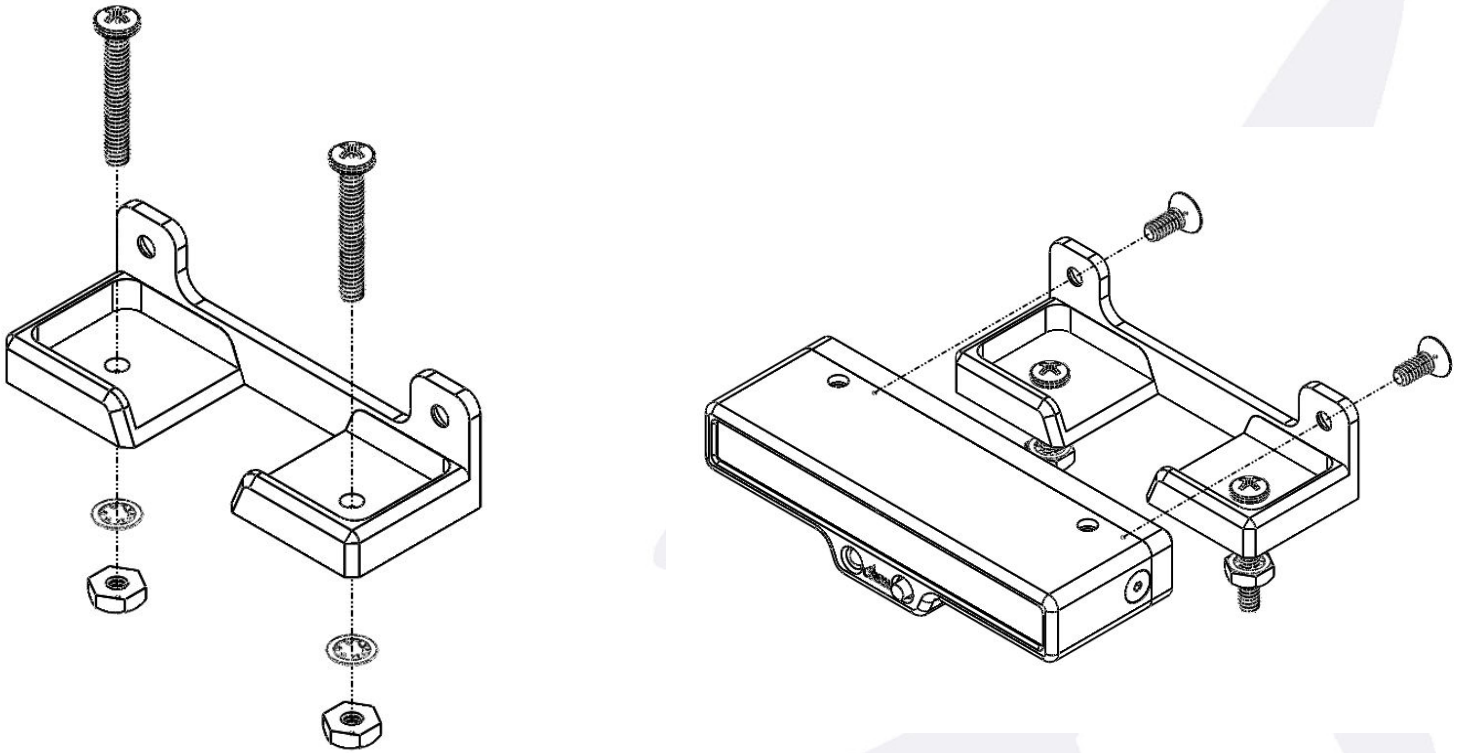

NOT TO SCALE

The Merlin display was designed to be viewed in the pilot's peripheral view without looking down when flying the aircraft. There are 3 mounting options to assist in any aircraft installation.

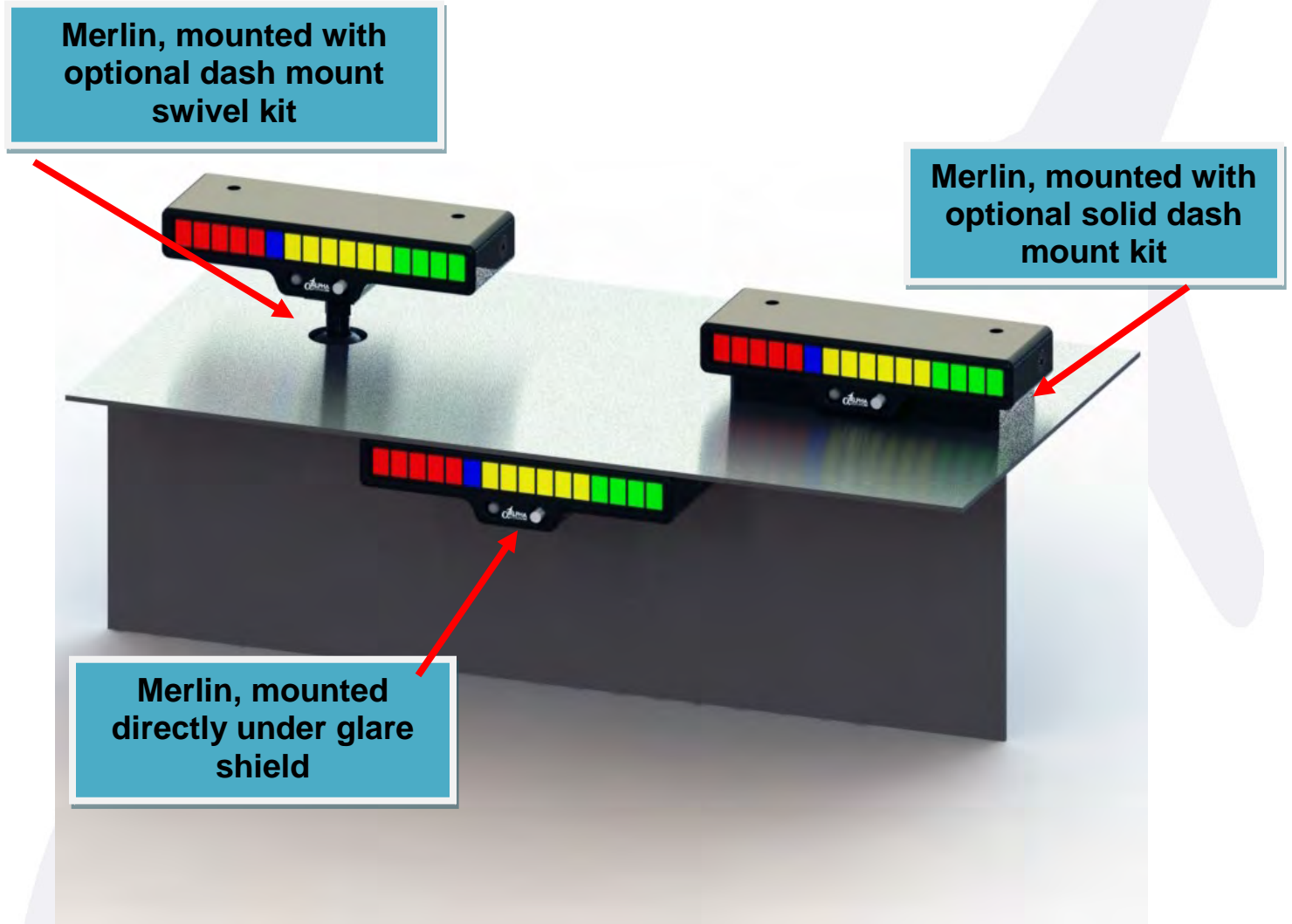

2. PLANNING

2.1 Preparation:

This chapter will guide you through the planning phase of the installation process. To prepare for the installation, it is recommended that you read this manual in its entirety and complete this chapter prior to performing any work.

2.2 Establish the Desired Location of the Angle of Attack Display:

The Alpha Systems AOA is intended to provide supplemental information; therefore, it cannot be used as a replacement for any required instruments.

There is some good guidance in AC43.13-2B Chapter 11 and FAR §23.1321 that refer to the location and installation of the instruments. Basically, the instruments should be arranged in the standard “T” configuration with the Alpha Systems AOA indicator, **preferably** as high and left of the attitude indicator as possible. The location should also allow routing of the electrical wiring so it will not interfere with any moving controls, cables or come in contact with any line containing flammable fluids or gases.

Since the Alpha Systems AOA Indicator is electronic, there are a number of other factors to be considered. For example, the intent of FAR 23.1311 is to cover installation of “CRT” or “LCD” displays that replace conventional analog instruments. Since the AOA system does not replace any required instruments and does not involve a “CRT or “LCD” display, this regulation does not apply. Showing compliance with this FAR can be done as follows:

- 23.1311 Electronic display instrument system
 - (a)(1) Arrangement and visibility; this requirement will have been met by complying with FAR 21.1321.
 - (a)(2) Be easily legible under all lighting conditions. This requirement has been met by design; the display is designed to be seen in direct sunlight and has a built in dimming device for lower levels of light.
 - (a)(3-7),(b)&(c) Does not apply since the system is stand alone and does not interface with, or replace any existing instruments or displays. It is not considered essential for flight.

Listed below are four different scenarios. Find and complete the one that pertains to your installation and use the following formula when calculating the additional load:

(Indicator Weight) X (Aircraft “G” Limit) X 1.5 (Safety Margin) = Additional Load

Example:
 .5lbs X 6.6 X 1.5 = 4.95 lbs.

- **If you are planning to install the indicator in an existing hole** on the instrument panel, then a determination is needed to insure that the fasteners/shock mounts will accept the additional load of the indicator. The indicator weighs .5 lbs. (or less, depending on the model). The addition of the indicator should not normally exceed the limits of the mounting hardware. This is a preferred method of installing the indicator and in most cases will require no additional alterations; hence a minor alteration. Please refer to AC43.13-2B Chapter 1 and Chapter 2 paragraph 203(a-e) for guidance.

- **If you are planning to install the indicator in a panel that is shock mounted and has no existing mounting hole present** you will need to make two determinations. First, will the shock mounts accept the additional load of the indicator and secondly, will the panel be strong enough with an additional instrument hole in it. The indicator weighs .5lbs (or less, depending on the model) so the addition of the indicator should not normally exceed the limits of the shock mounts. The panel strength should not be an issue if you keep the hole spacing the same as the original panel layout. This is also a preferred method of installing the indicator and in most cases will require no additional support structure, hence a minor alteration. Please refer to AC43.13-2B Chapter 1 and Chapter 2 paragraph 203(a-e) for guidance.
- **If you are planning to install the indicator on a glare shield** you will need to determine if the structure is strong enough to support the weight of the indicator. This is also a preferred method of installing the indicator, and in most cases will require no additional support structure; hence a minor alteration. Please refer to AC43.13-2B Chapter 1 and Chapter 2 paragraph 205(a-c) for guidance.
- **If you are planning to install the indicator in a panel where no mounting hole is present and the panel is not shock mounted**, two determinations will be required. First, if the panel is **non-structural**, you will need to determine that the mounting hardware will accept the additional load of the indicator and secondly, will the panel be strong enough with an additional instrument hole in it. The indicator weighs .5 lbs. (or less, depending on the model). The additional load of the indicator should not normally exceed the limits of the mounting hardware. The panel strength should not be an issue if you keep the hole spacing the same as the original panel layout. This method of installing the indicator will, in most cases, not require additional support structure; hence a minor alteration. If you intend to install the indicator in a **structural** panel, then this would be considered a **major alteration** and engineering data **may** be required and should be obtained prior to any work being performed. Please refer to AC43.13-2B Chapter 1 and Chapter 2 paragraph 203(a-e) for guidance.

2.3 Establish the Desired Location for the AOA Interface Module (IM):

The AOA Interface Module (**IM**) is used to convert pressures, measured at two points on the probe, to an electrical signal that is then delivered to the indicator - which displays angle of attack / lift information to the pilot. The AOA **IM** may be physically installed in a variety of locations while observing the following limitations:

- The structure must support the additional load of the module.
- The sense lines are routed so that they do not interfere with any moving controls or cables.
- The electrical wiring does not interfere with any moving controls or cables and shall not come in contact with any line containing flammable fluids or gases.
- The AOA **IM** must be bonded to the airframe (grounded for shielding).
- The AOA **IM** must be mounted within six feet of the AOA indicator.
- The AOA **IM** must be mounted within six feet of the power source, fused and connected with an on/off switch.

Note: *If a longer cable is required it may be possible to have a longer custom cable assembly fabricated. Contact Alpha Systems for more information (763) 506-9990.*

Use the following formula when calculating the additional load:

$$(\text{Module Weight}) \times (\text{Aircraft "G" Limit}) \times 1.5 (\text{Safety Margin}) = \text{Additional Load}$$

Example:

$$.8 \text{ lbs.} \quad \times \quad 6.6 \quad \times \quad 1.5 \quad = 7.92 \text{ lbs.}$$

If the AOA **IM** can be installed without additional support structure, then it would normally be a minor alteration. Please refer to AC43.13-2B Chapter 1 and Chapter 2 paragraphs 201, 202, 204-206 for guidance.

2.4 Establish the Location for the AOA Probe:

The AOA probe is mounted on the wing with the following limitations:

- The AOA probe is mounted a minimum of 24 in. outboard of the propeller arc.
- The AOA probe is mounted a minimum of 9 in. inboard of the wing tip.
- The AOA probe is mounted, with clearance, inboard or outboard of any struts or landing gear.
- The AOA probe is mounted between 10% to 90% of the Mean Aerodynamic Chord (MAC), or 6 inches from the leading edge and 10 inches from the trailing edge - center span optimal.
- If the heated probe is to be installed, the AOA probe must first be checked to verify that there is NO effect when turned on to any equipment such as a remote compass system.

For twin-engine aircraft, the AOA probe can be mounted on the nose on a non-structural area if approved by your A&P mechanic.

Due to the vast number of aircraft, wing designs, inspection locations, braces, struts and so on, the object of the "best location" is the probe to be mounted in "clean air flow / undisturbed air." At this location of the probe, all AOA angles, slips or attitudes would not affect the measurement of air present at the tip of the AOA probe. With this in mind, the AOA probe can be mounted on the nose area for twin engine or pusher type aircraft.

Remove the inspection cover and use it as a template to cut our standard 9" x 9" AOA probe mounting plate to the same shape and drill the same holes. If required, install a "doubler" plate for strength.

Note: For fabric wing aircraft, composite wing aircraft or dual prop aircraft, please contact Alpha Systems AOA for guidance with installation of the AOA Probe at (763) 506-9990.

Listed below are three different scenarios. Find and complete the one that pertains to your installation, and use the following formulas when calculating the additional load and drag.

$$(\text{Probe + Hardware Weight}) \times (\text{Aircraft "G" Limit}) \times 1.5 (\text{Safety Margin}) = \text{Additional Load}$$

Examples:

$$.6 \text{ lbs.} \quad \times \quad 6.6 \quad \times \quad 1.5 \quad = 5.94 \text{ lbs.}$$

$$(\text{Drag Coefficient}) \times (\text{Frontal Area of the Probe}) \times V_{NE}^2 = \text{Drag in lbs. at } V_{NE}$$

$$.000327 \quad \times \quad .064 \quad \times \quad 200^2 = .83712$$

- **If a non-structural inspection panel** is available, determine if the existing structure will support the additional load and drag of the probe and mounting hardware. Please refer to the airframe manufactures maintenance manual, AC43.13-2B Chapter 1 & Chapter 3 for guidance. This is the preferred method of installing the probe and in most cases will require no additional support structure; hence a minor alteration. However, if you have a very fast and/or a thin skinned aircraft the addition of supporting structure may be required. If so, this would be considered a major alteration.
- **If a structural panel is available** and used to support the probe, this would be considered a major alteration. Engineering data **may** be required and should be obtained prior to any work being performed. Please refer to the airframe manufactures maintenance manual, AC43.13-1B Chapter 4, AC43.13-2B Chapter 1 & Chapter 3 for guidance.
- **If no inspection panel is available** to support the probe, an inspection hole along with a doubler and/or supporting structure may be installed in the wings skin. This would also be considered a major alteration and engineering data **may** be required and should be obtained prior to any work being performed. Please refer to the airframe manufactures maintenance manual, AC43.13-1B Chapter 4, AC43.13-2B Chapter 1 & Chapter 3 for guidance.

2.5 Establish a Plan to Route the Sense Lines Through the Aircraft Structure:

Observe the following limitations:

- **Do not remove hose end caps until final connector installation.** This keeps contamination from entering the sense lines during installation.
- Minimum bend radius of 4" for the lines must be observed.
- Attach lines at regular intervals by means of suitable clamps.
- Do not clamp lines at the end fittings.
- Use AN931 Grommets (preferred) or bulkhead fittings where they pass through bulkheads.
- To install our system in a pressurized aircraft, Alpha Systems has created a pressurized kit to utilize existing electrical connector pass-through.
- Keep the lines well clear of any moving controls or cables.

Refer to the airframe manufactures maintenance manual and AC43.13-1B chapter 12 section 4 for instructions on replacing/installing new pitot-static lines.

2.6 Establish a Plan for the Electrical Power:

The Alpha Systems AOA unit requires approx. ¼ amp (250 mA) of electrical power within its acceptable voltage range of 12-32VDC. Our recommendation would be to have the Alpha Systems AOA draw power from the avionics bus, through an on/off switch and with a 1 Amp fuse or breaker in-series with the positive lead for the **IM** (this would offer some protection from surges during startup and the on/off switch enhances operational flexibility).

For additional information, please refer to AC43.13-1B Chapter 11 which has a wealth of information on wire, switches, loads, etc. AC43.13-2B Chapter 2 paragraph 207 is useful as well.

2.7 Optional AOA Probe Heat Installation:

The optional probe heat requires 8 Amps of electrical power at 12 or 28VDC. We recommend a separate 10 Amp dedicated breaker for the heated option.

Determine the size of wire required from AC43.13-1B Chapter 11 Section 5, (12VDC in free air, #14 wires will be adequate for runs up to 20' & for 24VDC in free air, #16 wires will be adequate for runs up to 25'). As an added precaution, to prevent interference with other aircraft systems, use MIL Spec. shielded wire. Electrical cable/wire must be installed such that the risk of mechanical damage and/or damage caused by fluids, vapors, or sources of heat, is minimized. Route as far away as possible from any instrument system or wiring that may be affected (i.e. Eaton 8500 K9, MS24523-22 SPST switch). AC43.13-1B Chapter 11 has a wealth of information on wire, switches, loads, etc., AC43.13-2B Chapter 2 paragraph 207 is useful, as well.

2.8 Review Your Plans:

Make sure that your plans meet the requirements of the following regulations:

§23.1301:

- (a) Is it of a kind and design appropriate to its intended function? **If you intend to add an Alpha Systems AOA and can do it as described above then the answer is "YES".**
- (b) Can it be labeled as to its identification, function? **The Alpha Systems AOA meets this identification requirement for the indicator. However, if you install the optional on/off switch or heated probe, then you are required to label the switch and circuit breaker(s) as to their function.**
- (c) Can it be installed according to limitations specified? **You must meet all specified requirements to answer this "YES".**

If you answered any of the above questions with a "NO," revise your plan until you can answer all the questions with a "YES".

§23.1309:

- (a) When performing its intended function, will it adversely affect the response, operation or accuracy of any:
 - Equipment essential to safe operations? **If the Alpha Systems AOA is installed correctly it should not affect any other equipment as it is a standalone system which does not interface with any other equipment. One exception is the optional heated probe which must be looked at very closely.**
 - Other equipment unless there is a means to inform the pilot of the effect? **Same as above; additionally, do not utilize a circuit breaker shared with any other piece of equipment for the Alpha Systems AOA or the heated probe in an effort to avoid this situation.**

Refer to AC23.1309-1D section 9. It will help you answer the previous questions and the flow chart helps to determine if the installation will meet the requirements of §23.1309(a).

If you answered either of these two questions with a “YES,” revise your plan until you can answer them both with a “NO.”

If you made it through this section successfully, you are now ready to install the Alpha Systems AOA in your aircraft.

(End of chapter)

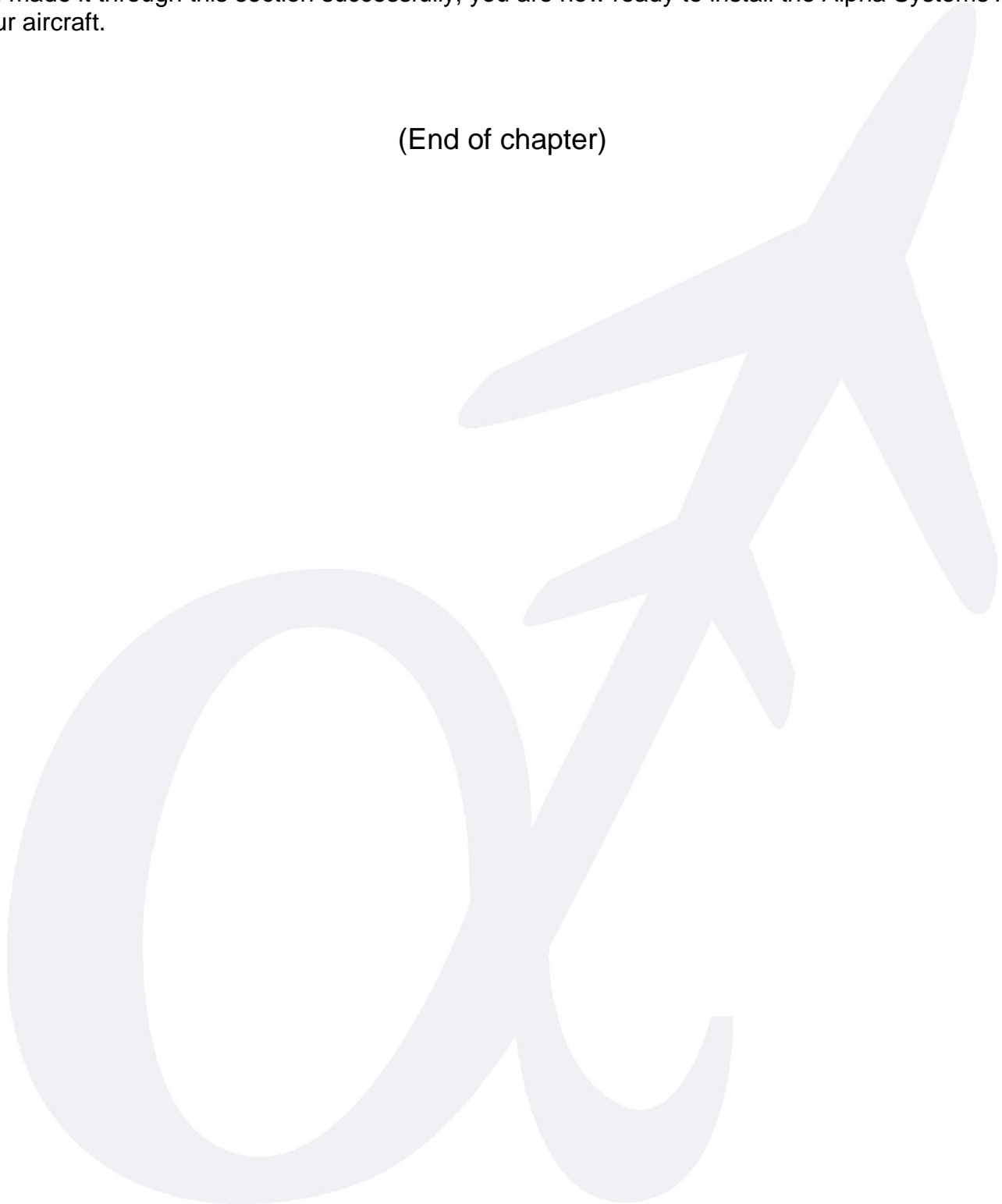

3. Installation

3.1 Preparing to Install the Probe:

In chapter two, the location for the probe was established. If it was determined that additional structure or modification to the wing will be required, perform that work now in accordance with the established plan and/or any required engineering data.

If not already done, remove the inspection panel at the location where the probe will be mounted.

Modify the AOA probe mounting plate to fit the hole (the panel removed may be used as a template or the brackets from the AOA plate may be removed and the AOA plate be used as a template to install the brackets to the existing plate).

Ensure that the slot in the mounting plate is aligned so that the rounded end faces forward (direction of flight).

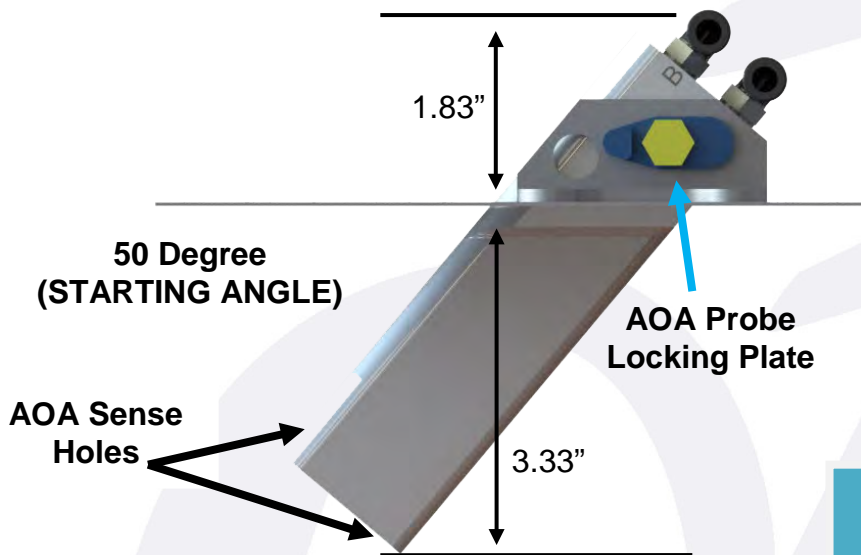

The design of this system requires that the AOA probe be mounted close to a 50 degree angle to the chord of the wing. Mounting the probe plate on a surface that is not parallel to the chord would require tilting and locking the probe at an increased or decreased angle referenced to the mounting plate, allowing the system to accept a correct OAA value.

The AOA probe mounting plate is cut to fit any desired shape or opening.

Weights:

- 1.) Probe and 2 fittings = .23 lbs.
- 2.) 9"x 9" plate + hardware = .40 lbs.
(Less when cut to fit existing opening)
- 3.) Add .25 lbs. with optional probe heat
- 4.) Weight of sense line is .02 lbs. / ft.
- 5.) .040", 6061-T6 Aluminum

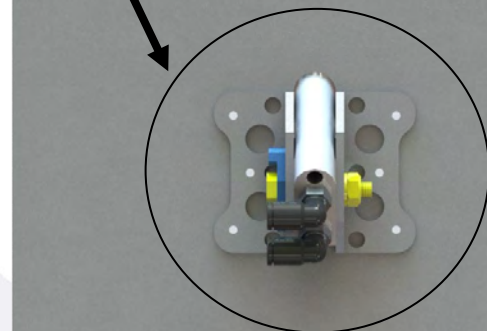

On a non-structural panel, the screw spacing should be no less than one screw every two to three inches along the circumference of the mounting plate. If the existing layout is greater, add nut plates as required to accomplish the proper screw spacing (on a structural panel the screw spacing would be much closer).

Drill holes in the probe mounting plate to match the layout in the wing. (Use the inspection panel as a template).

Install the mounting plate on the wing and check for a proper fit. When satisfied, remove the panel and prepare the panel for paint.

Finish panel as desired and set aside to cure.

3.2 Installation of the AOA Sense Lines:

Gain access to the aircraft so that the AOA sense lines can be installed and routed through the aircraft from the probe location to the AOA Interface Module location in accordance with the plan established in chapter two.

Route the sense lines and observe the following requirements:

- The sense lines have a minimum bend radius of 4”.
- Attach sense lines at regular intervals by means of suitable clamps.
- Do not clamp sense lines at the end fittings.
- Use AN931 grommets (preferred) or bulkhead fittings where the sense lines pass through bulkheads.
- To install our system in a pressurized aircraft, Alpha Systems has created a pressurized kit to utilize existing electrical connector pass-through.
- Do not remove the caps installed on either ends of the sense lines, and leave sufficient length so they may be cut to length later in the installation process.

Note: Keep the lines well clear of any moving controls or cables.

3.3 Install the Wiring, Switch & Circuit Breaker For the AOA System:

*Note: It may be advantageous to perform the steps in **section 3.4** at the same time the following work is performed, **if the optional probe heat is to be installed.***

In chapter two, a plan was established to ensure that the requirements for supplying power to the AOA system were satisfied. In accordance with that plan:

- Ensure that the aircraft electrical system is **NOT** powered and the aircraft battery is disconnected.
- Install the circuit breaker (**1 Amp**). Mount in a manner accessible to a crewmember during flight for circuit breaker resetting.
- Identify and label the circuit breaker.
- **(Optional)** Install the on/off switch so it is accessible to appropriate crewmembers. If installed, label the switch as to its operation.

(Continued on next page)

- Route the cable/wire from the circuit breaker to the on/off switch (if installed), then to the control module location. Observe the following:
 - Keep wires clear of any moving controls or cables.
 - Physically separate electrical wire from lines or equipment containing oil, fuel, hydraulic fluid, alcohol or oxygen.
 - Route wires above flammable fluid lines and securely clamp to structure.

WARNING: *In no case may a wire be clamped to a line containing flammable fluids.*

- Connect the **WHITE WIRE (NO Stripe)** to power (+).
- Connect the **WHITE WIRE WITH BLUE STRIPE** to an adequate ground (-).

Note: *If additional wire was used, ensure the wire is identified / labeled, tested for proper connection and insulated properly.*

- Attach the shielding together at a break in the wire (i.e. at the switch) and ensure it is insulated so as to prevent contact with any other conductor. Do not connect the shield to ground as it is grounded at the connector; doing so would cause a ground loop.
- Recheck for proper polarity.**
- (+, power) = White wire.**
- (-, ground) = White with Blue Stripe.**

3.4 Install the Wiring, Switch and Circuit Breaker For the Probe Heat:

Note: *This section may be skipped if the optional AOA probe heat is not to be installed.*

In chapter two, a plan was established so that the requirements for installing the probe heat were satisfied. In accordance with that plan:

- If not already done so, ensure that the aircraft electrical system is **NOT** powered and the aircraft battery is disconnected.
- Install the circuit breaker (**10 Amp**). Mount in a manner accessible to a crewmember during flight for circuit breaker resetting.
- Identify and label the circuit breaker.
- Install the on/off switch so it is accessible to appropriate crewmembers.
- Label the switch as to its operation.
- Label the wire so it may be identified once installed.

See **optional** switch relay electrical schematic for dual, AOA & pitot, heat power.

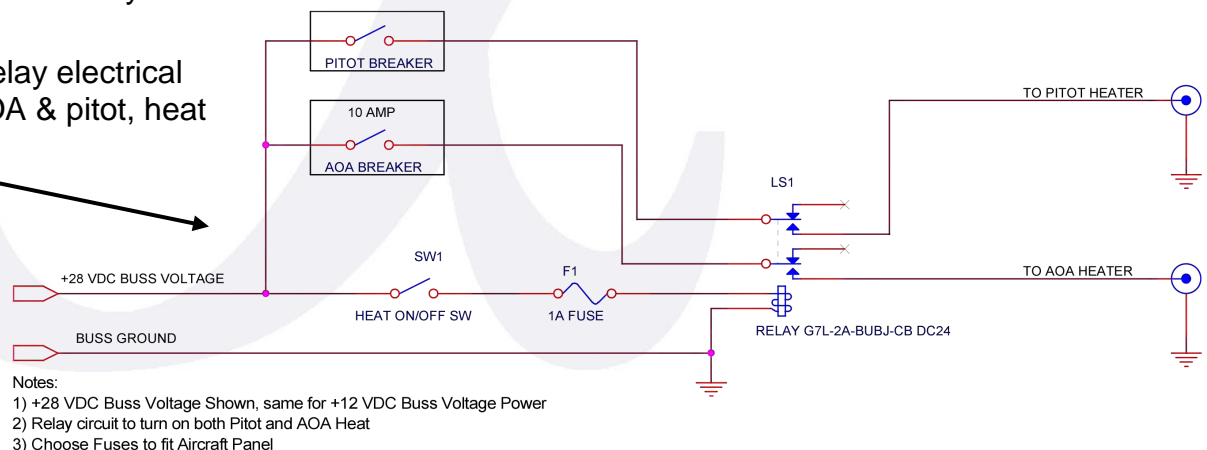

Install the wire from the circuit breaker, through the switch, to the probe location and to a suitable ground. Observe the following:

- Physically separate electrical wire from any lines or equipment containing oil, fuel, hydraulic fluid, alcohol or oxygen.
- Route wires above any flammable fluid lines and securely clamp to structure.

WARNING: *In no case may a wire be clamped to a line containing flammable fluids.*

- Route as far away as possible from any instrument, system or wiring that may be affected (i.e. compass/flux gate, antenna or antenna coax).
- Leave sufficient wire at the probe location so it may be cut to length and connected to the probe later in the installation process.

Attach the shielding to a suitable ground on one end of the wire only to prevent a ground loop. Attach the shielding together at a break in the main conductor (i.e. at the switch connections) and ensure it is insulated as to prevent contact with any other conductor.

3.5 Install the AOA Display:

In chapter two, the location for the AOA display was established. If it was determined that additional structure or modification to the instrument panel will be required, perform that work now in accordance with the established plan and/or any required engineering data.

The Alpha Systems AOA cannot be placed in the cockpit in such a manner as to obstruct the pilot's view or cause distraction.

The Alpha Systems AOA cannot be placed in the cockpit in such a manner as to interfere with the pilot's view of primary flight instruments.

Install the AOA display and check for fit and clearances. The AOA display may be mounted using the four (6x32) threaded mounting holes. This allows the AOA display to be mounted and positioned so that the display is up as high in the cockpit as possible, preferably on top of the glare shield, allowing a view of the aircraft's AOA without looking down to see the display.

Route the cable from the AOA display to the AOA **IM** location. Observe the following:

- Keep wires well clear of any moving controls or cables.
- Physically separate electrical wire from lines or equipment containing oil, fuel, hydraulic fluid, alcohol or oxygen.
- Mount electrical wire bundles above flammable fluid lines and securely clamp to structure.

In a dual system, route the cables from both AOA displays to the **Dual Display Interface** using the provided display extension cables.

WARNING: *In no case may a wire be clamped to a line containing flammable fluids.*

3.6 Install the AOA Interface Module (IM):

In chapter two, the location for the AOA Interface Module (**IM**) was established. If it was determined that additional structure or modification will be required, perform that work now in accordance with the established plan and or any required engineering data.

Attach the AOA **IM** to the airframe utilizing the attached mounting base plate. The AOA **IM** must be grounded for shielding. If the module is not grounded by the mounting hardware, install a grounding strap from one of the mounting screws to a suitable ground.

Cut the AOA sense lines (at a 90° angle, **NO burs**) to length with a razor blade and insert the lines firmly in the connectors. Observe the color coding: **BLUE / FRONT connector → blue sense line AND WHITE / BOTTOM connector → white sense line**. When correctly installed, the line will be inserted approximately 3/8" into the connector.

Note: Push hose into connector until it stops.

Ensure the line is installed correctly by giving the tubing a light pull. If the tubing does not back out, it is a good connection.

How to remove the tubing from Quick-Release fittings:

- Using a ¼" box end wrench, or your fingers. Push down the release ring on the fitting and then pull air tube to remove.

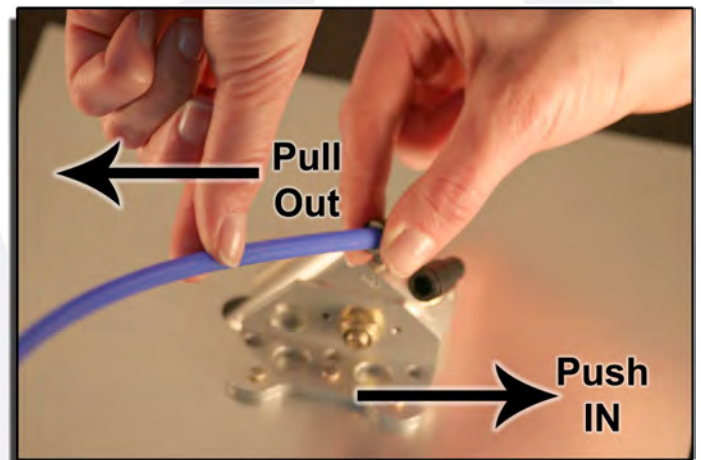
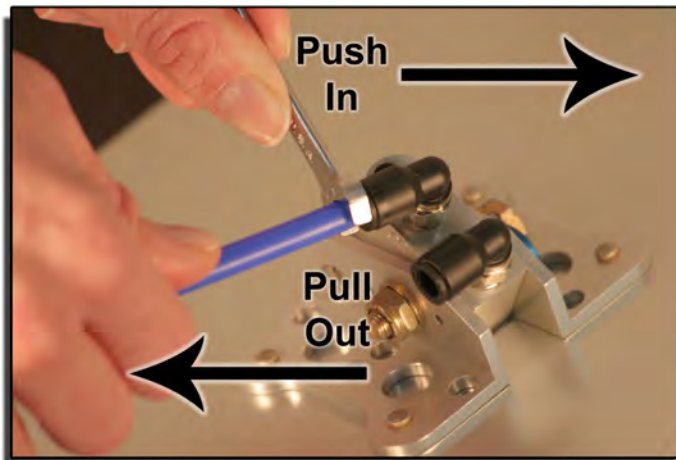

Quick installation hint!

The Alpha Systems AOA utilizes push-in fittings. Once the hoses are installed, draw a line on the hose at the junction of the fitting. Remove hose and reinsert, verifying the hose is inserted completely to the line. If the reinsertion of the hose covers the line, the hose was not inserted fully the first time!

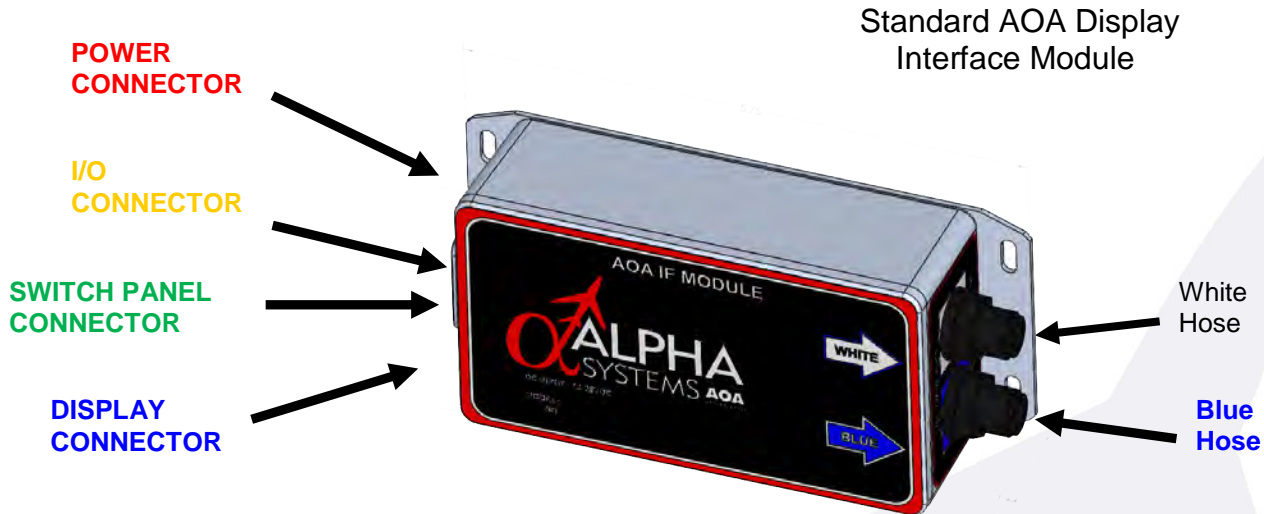

Note: The blue and white hose connects to the **Sensor Interface Module** in a pressurized system.

Connect the display cable connector (10 pin) to the AOA Interface Module (**IM**) connector - they are both color coded **BLUE**. This may be accomplished by holding the cable connector by its black strain relief and rotating it on the **IM** display connector until the alignment keyways mate up. Then, push towards the control module and the retaining collar will snap into place tightly against the AOA **IM**.

Connect the switch panel cable connector (6 pin) to the AOA **IM** connector – they are both color coded **GREEN**. This may be accomplished by holding the cable connector by its black strain relief and rotating it on the **IM** power connector until the alignment keyways mate up. Then, push towards the AOA **IM** and the retaining collar will snap into place tightly against the AOA **IM**.

Connect the power cable connector (4 pin) to the AOA **IM** connector - they are both color coded **RED**. This may be accomplished by holding the cable connector by its black strain relief and rotating it on the **IM** power connector until the alignment keyways mate up. Then, push towards the AOA **IM** and the retaining collar will snap into place tightly against the AOA **IM**.

Note: Pull lightly on the wire. If the connector stays on the **IM**, the connector is seated completely.

To remove either of the electrical connectors, grip the collar and pull away from the AOA **IM**. The connector will slide off.

The DB 15 pin connector on the **IM** marked with **YELLOW** is for the audio interface and future I/O connections.

In a pressurized system, the **YELLOW** connector connects to the audio. However, it also connects to the power, ground, and sensor output wires of the **Sensor Interface Module**.

3.7 Install the AOA Probe and Mounting Plate:

Due to the vast number of aircraft and the wide variety of possible inspection cover locations, Alpha Systems AOA has designed an AOA sense probe that can be tilted and locked at different angles, ranging from 35 degrees to 90 degrees. This design allows for the deviation or tilt of the skin surface difference from the chord of the wing while allowing for the AOA probe to be “pinned” in place to get an accurate full-scale range of AOA output.

Install the AOA probe in the mounting plate and secure it as follows:

- Locate the 50° index hole on the AOA probe using the following figure as a starting angle.
- Insert the AN ¼-28 bolt through the probe lock plate. Make sure that the pin on the probe lock plate faces the thread side of the bolt.
- Insert the AOA probe through the mounting bracket and line up the bolt hole in the AOA probe with the bolt hole in the mounting bracket.
- Insert the AN ¼-28 bolt and probe lock plate loosely through the AOA mounting bracket and AOA probe from the left side (looking at AOA probe from rear).
- Line up the 50° index hole on the AOA probe with the front hole in the mounting bracket. Insert the longer pin on the probe lock plate through the front hole on the mounting bracket and into the 50° hole on the AOA probe. The probe lock plate location should match the following figure.

Note: Refer to Appendix section 5.2 AOA Probe Angles on page 5.12 and 5.13 for more information on the probe lock plate.

AOA Probe Pin Positions – Left Side

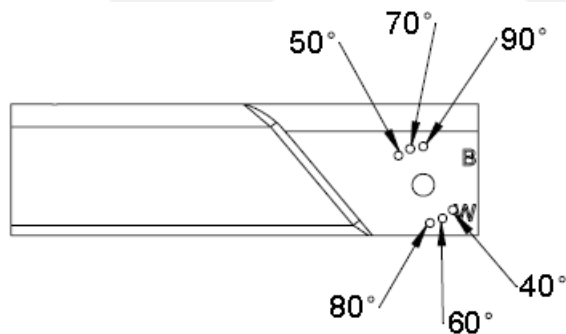

AOA Probe Pin Positions – Right Side

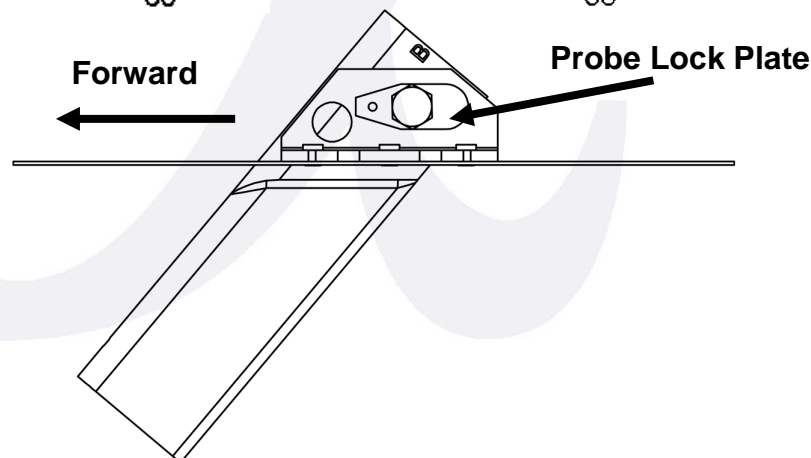
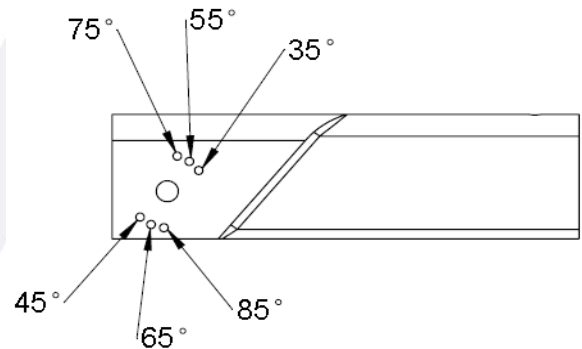

3.8 Correct Position of Probe Lock Plate:

Note: The probe lock plate can face forwards or backwards and can be placed on either the left or right side of the AOA probe depending on which pin hole is selected on the AOA probe.

It may be necessary to remove material from the mounting plate that would prevent the AOA probe from being installed at the proper angle. If the 50° (or less) angle of the AOA probe interferes with the plate, or in the final calibration steps the AOA probe needs to be at a tighter angle, remove material from the mounting plate only as required to allow enough range of motion for accurate calibration.

CAUTION: *Drilling out the probe is not needed and will nullify the warranty.*

To finish the AOA probe installation:

- Install the washer and nut onto the AN4 bolt and tighten it so the AOA probe will not move in flight.
- Use the included protractor to confirm that the AOA probe is at an initial 50° angle. If not, loosen the nut enough that the probe lock plate can be backed out of the mounting bracket enough to rotate the AOA probe until the correct hole is lined up. Then, reinsert probe lock plate and retighten bolt and nut.
- Cut the sense lines (at a 90° angle, **verify NO burrs**) to length so they may be easily attached to the AOA probe but short enough so they will not kink when the mounting plate is secured to the wing. Allow enough hose to re-position the AOA probe angle for final adjustments.
- Insert the lines firmly in the connectors. Observe the two letters on the side of the AOA probe, **“B” for blue** (Front Hole) → **BLUE LINE** and **“W” for White** (Bottom Hole) → **WHITE LINE**. When correctly installed, the tube is inserted approximately 5/8 in. into the connector. Push hose in firmly until a positive stop is felt.

Note: *Ensure the lines are installed correctly. The Alpha Systems AOA utilizes push-in fittings. Once the hoses are installed, draw a line on the hose at the junction of the fitting. Remove hose and reinsert, verifying the hose is inserted completely to the line. If the reinsertion of the hose covers the line, the hose was not inserted fully the first time! If you ever need to disconnect the lines depress the black collar (the furthest outboard portion of the connector) on the fitting and pull the line out.*

- Slowly slide the AOA probe and mounting plate into position ensuring that everything will fit properly (no kinks or bends). When satisfied, secure the mounting plate to the wing and tighten all screws.

(Optional) If installing a heated probe, it will come from the factory installed with high temperature fittings and colored (**Blue / White**) high temperature hoses with the heater in the AOA probe.

(Optional) Cut the electrical wires for the AOA heated probe to length and connect them to the heater. Polarity is not an issue. Connect power to one lead and ground to the other. Attach the shielding to a suitable ground on one end of the wire only; this will prevent a ground loop.

3.9 Inspect the AOA Installation:

Follow these steps to inspect the AOA system installation:

- Inspect in the areas that were opened to install the AOA sufficiently so you can determine that the installation was done correctly and no discrepancies are left unresolved.
- Connect the aircraft battery and close any open circuit breakers for the AOA system and probe heat.
- Turn on the aircraft's electrical system and the AOA unit, then the probe heat, if installed. Disregard any AOA indications at this time.

Note: *The Alpha Systems AOA display will be flashing ALL AOA segments; this indicates ALL calibrations need to be made BEFORE it is functional.*

- **Power off the system.**
- Re-inspect the areas that were opened to install the AOA system, paying particular attention to the electrical part of the installation. Determine that there are no unresolved issues with the electrical part of the installation.
- If probe heat was installed, check the operation of the probe heat with the switch in the "on" and "off" position. Ensure the compass or other systems are **NOT** affected by the probe heat.

WARNING: When finished, turn the probe heat off. When you check the AOA probe heater, **DO NOT TOUCH THE AOA PROBE!** Use a thermometer or place your hand above the probe to feel the radiated heat. Leaving the probe heat on for extended periods while on the ground will shorten its service life.

- Close the aircraft up by installing any access panels or equipment removed to install the AOA.

(End of chapter)

4. DOCUMENTATION

4.1 Background Information:

The Alpha Systems Angle of Attack System (AOA) may be installed on many aircraft models numerous ways. For this reason we cannot point you to a boiler plate logbook entry or sign off that will be good for all aircraft. We will help you through the documentation process by explaining pertinent topics and direct you in the proper direction by employing those topics in sample logbook entries.

4.2 Major vs. Minor Alteration:

In subject 1.3 we discussed the difference between a major and minor alteration, again ***“a minor change is one that has no appreciable effect on the weight, balance, structural strength, reliability, operational characteristics or other characteristics affecting the airworthiness of the product.”*** In Chapter 2, some scenarios were listed that may, in our judgment, make the installation a major alteration; **however, this determination is the responsibility of the person performing the installation.** If a determination was made that:

- The alteration was a **minor** alteration, the aircraft can be returned to service by an appropriately rated mechanic or by an individual that holds a repairman’s certificate for that specific aircraft by documenting the alteration in the aircraft records.
- The alteration was a **major** alteration, the FAA must be informed. The form used to report the alteration and the FAA’s response shall be determined by what part of the FAR’s the aircraft was certified under. For example:
 - If a certified mechanic with “Inspection Authorization” (IA) **performs** a major alteration to a type certificated aircraft using **approved data** (STC’s, AD’s, etc.), he/she must report that alteration to the FAA on a form 337 by mailing it to them at Oklahoma City within 48 hours of returning the aircraft to service, no response is required by the FAA.
 - If a certified mechanic with “Inspection Authorization” (IA) **intends** to make a major alteration to a type certificated aircraft using **acceptable data** (i.e. AC43.13-1B, AC43.13-2B, etc.), he/she must submit a FAA form 337 to the local **FSDO** describing the work to be completed and reference the acceptable data **prior to commencing the work**. The FAA’s response will normally be to approve the acceptable data by signing block 3 on the 337 form and return it to the mechanic. This is referred to as a “Field Approval.” Once the alteration is completed and the aircraft is returned to service the mechanic must mail the completed 337 form to the FAA at Oklahoma City within 48 hours of returning the aircraft to service.
 - If a certified mechanic or a person holding a repairman’s certificate for a specific experimental aircraft make or intend to make a major alteration to that aircraft they must report that alteration to the appropriate **FSDO** and **receive a written response prior to further flight**. There is no specific form that must be used to report the alteration; however the FAA will use the data you submit to determine if your alteration would require your aircraft to be returned to Phase 1 for further flight testing. It would be to your benefit to report the alteration using references of acceptable data so your aircraft will not be returned to Phase 1 unnecessarily.

4.3 Logbook Entries:

The pertinent parts of FAR § 43.9 (in italics) that describe the requirements for content, form, and disposition of alteration records that pertain to the AOA installation are listed below. I will explain the intent of the FAR as it applies to this installation.

FAR 43.9 – Content, Form, and Disposition of Maintenance Records:

*(a) Each person who maintains, performs preventive maintenance or **alters an aircraft** shall make an entry in the maintenance record of that equipment containing the following information:*

*(1) A description (or reference to data acceptable to the Administrator) of work performed. **The FAA would like a description of the work completed and under what authority was this alteration done. Your description of the work along with references to acceptable data satisfies this requirement. Acceptable data, listed in chapter two of this manual, may be used to support the description of the alteration.***

*(2) The date of completion of the work performed. **Self-explanatory.***

*(3) The name of the person performing the work if other than the person specified in paragraph (a)(4) of this section. **If work was performed on an airframe by anyone who does not hold an airframe mechanic/repairmen certificate, which is allowed under the authority of FAR § 43.3(d), their name should be included in the logbook entry.***

*(4) If the work performed on the aircraft has been performed satisfactorily, the signature, certificate number, and kind of certificate held by the person approving the work. The signature constitutes the approval for return to service only for the work performed. **The FAA wants to know who is responsible for returning the aircraft to service. This could vary from a private pilot performing preventive maintenance in accordance with § 43.3(g) to an A&P mechanic with IA returning a certified aircraft to service after a major alteration. Please refer to subject 4.2 for a more in depth explanation of who can return your aircraft to service after the installation of the AOA system.***

*(d) In addition to this entry, major alterations shall be entered on a form, and the form disposed of, in the manner prescribed in appendix B, by the person performing the work. **This is the requirement to notify the FAA described in the 4.2 section of this manual.***

Following this criteria, here is a list of examples of different situations pertaining to logbook entries:

For the first example, an A&P mechanic, Stacy, installs the angle of attack system in a customer's Flight Master 128 - a certified aircraft. She has made a determination that the installation is a minor alteration. In this case, only a logbook entry is required to return the aircraft to service. She could make the following basic entry fulfilling the requirements of § 43.9:

-March 22, 2015- Installed an Alpha Systems Angle of Attack System, part number DSTR-AOA-XXXXK, in accordance with the Alpha Systems Installation Manual, IOM-Merlin, Rev XX.

*Stacy R. Aviator
A&P 546324567*

However, Stacy is a very conscientious mechanic and wants to make an entry that not only meets the FAR requirements but also documents the alteration in enough detail so that if a question arises in the future, it can be remedied by simply reading the entry. She decides to make the following entry:

March 22, 2015

Aircraft Total Time: 358.2

To facilitate installing an Alpha Systems Angle of Attack System, part number DSTR-AOA-XXXXK, the following work was performed:

- *Removed an existing inspection panel on the left wing 24" inboard of the wing tip at station 121. The probe mounting plate was trimmed to fit the opening and attached with a quantity of 8 AN526C832R8 screws. Successfully performed a structural analysis and static test in accordance with AC43.13-2B Chapter 1. Removed the mounting plate, prepped, primed and painted the mounting plate.*
- *Routed two sense lines from the left glare shield to the location of the probe in the left wing in accordance with AC43.13-1B Chapter 12 Section 4 Paragraph 61(a & b).*
- *Installed the probe, part number AOA-4027, to the probe mounting plate and connected the sense lines. Installed the probe assembly to the opening on the left wing at station 121 and attached with a quantity of 8 AN526C832R8 screws.*
- *Installed an Alpha Systems Angle of Attack Indicator, part number DSTR-AOA-XXXX, serial number AOAIXXXX-XX, above the airspeed indicator on top of the glare shield in accordance with AC43.13-2B Chapter 1 and Chapter 2 paragraph 205(a-c).*
- *Installed an Alpha Systems Angle of Attack, AOA Interface Module, part number DSTR-AOA-XXXXM, serial number DSIXXXX-XX, behind the instrument panel on the avionics shelf at station 119, in accordance with AC43.13-1B Chapter 11, AC43.13-2B Chapter 1 and Chapter 2 paragraphs 201, 202, 204 & 207.*
- *Inspected the Alpha Systems AOA installation and performed the initial system power up, the zero pressure (on the ground) set-point calibration and (on the ground) brightness calibration procedures.*

Additionally, all work described above was done in accordance with the Alpha Systems Installation Manual, IOM-Merlin, Rev XX and in accordance with § 21.93(a) & 43.13(b). This airframe alteration is considered a minor alteration and is at least equal to its original condition.

The "In-Flight" calibration procedures need to be performed in accordance with the Alpha Systems Operations Manual and the satisfactory results recorded in the permanent aircraft records.

*Stacy R. Aviator
A&P 546324567*

Note: *If this was an experimental aircraft and the owner held a repairman certificate for that specific aircraft, he/she could also return the aircraft to service.*

After the “In-flight” calibration of the angle of attack (AOA) system, the aircraft owner made the following entry:

July 23, 2015

Aircraft Total Time: 359.3

A series of flights were made to successfully complete the in-flight calibration procedure. The probe angle after calibration is 50 degrees. The probe mounting bolt was tightened, the set screw was installed and the mounting plate was reinstalled. Actions performed in accordance with the Alpha Systems Operations Manual.

Joe B. Aviator

Commercial Pilot Certificate # 546324567

In this next example, an aircraft owner is very handy but does not hold a mechanic or repairmen’s certificate and would like to do the installation. Under FAR § 43.3(d) the installation may be performed under the supervision of a certificated mechanic. Stacy has developed a good reputation for doing a nice job on the installation of the AOA system and has agreed to supervise Paul. She adds Paul’s name as the person performing the work when she makes the logbook entry.

August 12, 2015

Aircraft Total Time: 1432.2

To facilitate installing an Alpha Systems Angle of Attack System, part number DSTR-AOA-XXXXK, the following work was performed:

- Removed an existing inspection panel on the left wing 32” inboard of the wing tip at station 136. The probe mounting plate was trimmed to fit the opening and attached with a quantity of 8 AN526C832R8 screws. Successfully performed a structural analysis and static test. Removed the mounting plate, prepped, primed and painted the mounting plate.*
- Routed two AOA sense lines from the left instrument panel to the location of the probe in the left wing.*
- Installed the AOA probe, part number AOA-4027, to the probe mounting plate and connected the AOA sense lines. Installed the probe assembly to the opening on the left wing at station 136 and attached with a quantity of 8 AN526C832R8 screws.*
- Installed an Alpha Systems Angle of Attack Indicator, part number DSTR-AOA-XXXX, serial number AOAIXXXX-XX, left of the airspeed indicator in an existing hole.*
- Installed an Alpha Systems Angle of Attack AOA Interface Module, part number DSTR-AOA-XXXXM, serial number DSIXXXX-XX, on the base of the glove box at station 124.*
- Inspected the Alpha Systems AOA installation and performed the initial system power up, (on the ground) zero pressure set point calibration and (on the ground) brightness calibration procedures.*

Additionally, all work described above was done in accordance with AC43.13-1B Chapter 11 & 12 section 4 Paragraph 61(a & b), AC43.13-2B Chapter 1 & 2 paragraphs 201, 202, 203(a-e) & 207 as well as in accordance with the Alpha Systems Installation Manual, IOM-Merlin, Rev XX by Paul R. Pilot under my supervision. In accordance with FAR § 21.93(a) & 43.13(b), this airframe alteration is considered a minor alteration and is at least equal to its original condition.

The in-flight calibration procedure needs to be performed in accordance with the Alpha Systems Operations Manual and the satisfactory results recorded in the permanent aircraft records.

*Stacy R. Aviator
A&P 546324567*

On the above entry, notice that the references to acceptable data were listed at the end of the entry, rather than with the individual steps. Either way is acceptable.

Paul is a student pilot, so he had his flight instructor make the calibration flight and the following logbook entry:

August 16, 2015

Aircraft Total Time: 1432.8

The AOA in-flight calibration procedures were successfully performed in accordance with the Alpha Systems Operations Manual.

*Justin C. Lindberg
Commercial Pilot Certificate # 546324567*

Justin is not a mechanic or the aircraft owner, so Stacy performed the work listed in her entry below:

August 16, 2015

Aircraft Total Time: 1432.8

The probe mounting bolt was tightened, the set screw was installed and the mounting plate was reinstalled. Actions performed in accordance with the Alpha Systems Installation Manual, IOM-Merlin, Rev XX.

*Stacy R. Aviator
A&P 546324567*

Stacy's name is getting around and she is doing quite a few of the AOA installations. She is approached by a customer that has a Flight Master 240, a twin, and he would like the Alpha Systems AOA system with the probe heat option. After reviewing Chapter 2, she determines that the only thing that would qualify as a major alteration is the addition of the probe heat because of the electrical load. She explains this to the aircraft owner and offers two options: The first option is to fill out an FAA form 337 for the entire AOA installation and submit it to the FAA for a field approval. The second option is to do the installation now as a minor alteration, without the probe heat, and submit the paper work for the addition of the probe heat and install it at a later date. The owner decides to have the AOA system installed now since he will be back later this fall for the annual anyway. Stacy did the installation and made a similar logbook entry as before, and she followed AC43-210 and submitted a 337 form along with Instructions for Continued Airworthiness (ICA) to the FAA for a field approval of the probe heat. Below is the narrative from box 8 of the 337 form:

Flight Master 240 Serial number: 123, Registration: N14U, August 18, 2015

Paragraph 1.) The objective of this alteration is to install the probe heat option to a previously installed Alpha Systems angle of attack system.

Paragraph 2.) Install heated probe in accordance with the Alpha Systems Installation and Operations Manual, IOM-Merlin, REV XX and AC43.13-1B Chapter 11 and AC43.13-2B Chapter 2 paragraph 207.

----- END -----

Before requesting a field approval, ensure your request meets the criteria for a major alteration, fill out the paper work completely, and use appropriate acceptable data and keep it simple. The FAA does not want to spend time reviewing requests for field approvals when the alteration can be done as a minor alteration.

Below is another example from box 8 of FAA 337 form. Stacy submitted this prior to doing the work on Joe's AOA installation. The work was done the morning of July 22, and she made an appropriate logbook entry prior to beginning the work on the AOA installation.

Flight Master 128 Serial number: 321, Registration: N4JA, July 12, 2015

Paragraph 1.) The objective of this alteration is to install an inspection panel, identical to other inspection panels found along station 121. The inspection panel will be located in the lower skin of the left wing, 24" inboard of the wing tip equally distant between two ribs at station 121.

Paragraph 2.) Cut a 4" x 6" oval hole in the area described in paragraph 1. Install a doubler assembly, Flight Master part number DBLR-240LW. Fabricate an inspection cover from .032" 2024-T3 aluminum prep and paint. Secure the inspection cover with Qty. 8 AN526C832R8 screws. Work was performed in accordance with the AC43.13-1B Chapter 4 Section 4.

----- END -----

For more information please refer to AC43-210 which describes the field approval process and AC43.9-1F, instructions for completing the 337 form.

4.4 Documentation Review:

If the installation is determined to be a **minor** alteration, the aircraft can be returned to service with a logbook entry made by a certificated mechanic or a person that holds a repairman's certificate for that specific aircraft.

If the installation is determined to be a **major** alteration, the aircraft can be returned to service with a logbook entry made by a person that holds a repairman's certificate for that specific aircraft, certificated mechanic or a certificated mechanic with inspectors authorization (depending on the aircraft) **AND** the FAA has been informed of the major alteration and a written response is received authorizing flight after the alteration or a Field Approval is granted.

The calibration flight(s) may be conducted under §91.407 by at least a private pilot that is rated to fly the aircraft. §91.407(b) regarding carrying persons other than crew members. This only applies if the alteration has appreciably changed its flight characteristics or substantially affected its operation in flight; which is not the case with this alteration. The adjustment and tightening of the probe may be accomplished by a mechanic, a person that holds a repairman's certificate for that specific aircraft or the aircraft owner if they hold at least a private a private pilot certificate under part §43.3(g) and Appendix "A" to Part §43 item (c)(26). These events need to be documented by the person performing the procedure(s); it can be done in one entry if performed by the same person.

The logbook examples demonstrate various ways to document work. Detailed entries require additional time and effort, but may be invaluable down the road if questions arise. **In addition, many people judge the quality of the work performed by the logbook entry.** One word of caution is that when doing your installation and paper work include only references that were actually complied with. Including references that were not actually complied with, just to make the entry look better, could be considered fraud.

Note: *In an effort to make the documentation process easier, the entry can be made on any computer and printed (do not use water based ink) on plain paper and attached to the log book using a glue stick.*

(End of chapter)

5. APPENDIX

5.1 Acronyms and Abbreviations

Acronyms and abbreviations used in this manual are defined as follows:

TERMS	DEFINITION
AC	Advisory Circular
AMP	Ampere
AOA	Angle of Attack
AP	Audio Panel
CL	Coefficient of Lift
CFR	Code of Federal Regulations
CLmax	Coefficient of Lift Maximum
Cd	Coefficient of Drag
CL/Cd	Coefficient of Lift over Coefficient of Drag
FAA	Federal Aviation Administration
FAR	Federal Air Regulations
FSDO	Flight Standards District Offices
IF module	Interface Module
IA	Inspection Authorization
MAC	Mean Aerodynamic Cord
MIL	Military
OAA	Optimum Alpha Angle
Vx	Speed that allows for best angle of climb
Vy	Speed that allows for the best rate of climb
STALL	Unable to maintain controlled flight
CAA	Critical Alpha Angle (STALL)
Va	Maneuvering speed
MAA	Maneuvering Alpha Angle

5.2 Operational and Environmental Limitations

Operating Airspeed Range:	Minimum 25 knots TAS Maximum 500 knots TAS
Operating Altitude Range:	Minimum 0 Ft MSL Maximum 30,000 Ft MSL
Operating Humidity:	Maximum 96% Relative Humidity
Operating Temperature Range:	Minimum -20°C (-4°F) Maximum 66°C (151°F)
Storage Temperature Range:	Minimum -30°C (-22°F) Maximum 85°C (185°F)
Voltage operating range:	Minimum 12 Volts Maximum 28 Volts
Electrical load:	IF Module: <200 mA at 14 VDC <100 mA at 28 VDC Heated Probe <8 AMP at both 12 VDC or 24 VDC
Angular Operation:	-5 to +25 degrees angle of attack.
Precipitation:	The AOA probe functions properly when flown through non-icing precipitation.
De-icing Fluid:	No de-icing fluid restrictions on probe.
Sideslip Operation	+/- 15 deg Note: At sideslip angles of greater than 15 degrees, the accuracy may be diminished. However, the error will cause the warning indications to provide a greater margin of safety prior to wing stall.
Calibration Accuracy	A properly calibrated system will result in an accuracy of +/-3% over the full scale of the calibration.

5.3 Diagrams



Merlin Display

Calibration Set Points:	
1 - Ground	(Zero Set Point)
2 - Indication of Impending STALL	(CAA)
7 - Optimum Alpha Angle (OAA)	(1.3 x Vs)
17/18 - Cruise Alpha	(Va or Maneuvering Speed)

Note: Display Option 1





Note: Display Option 2



Note: Display Option 3

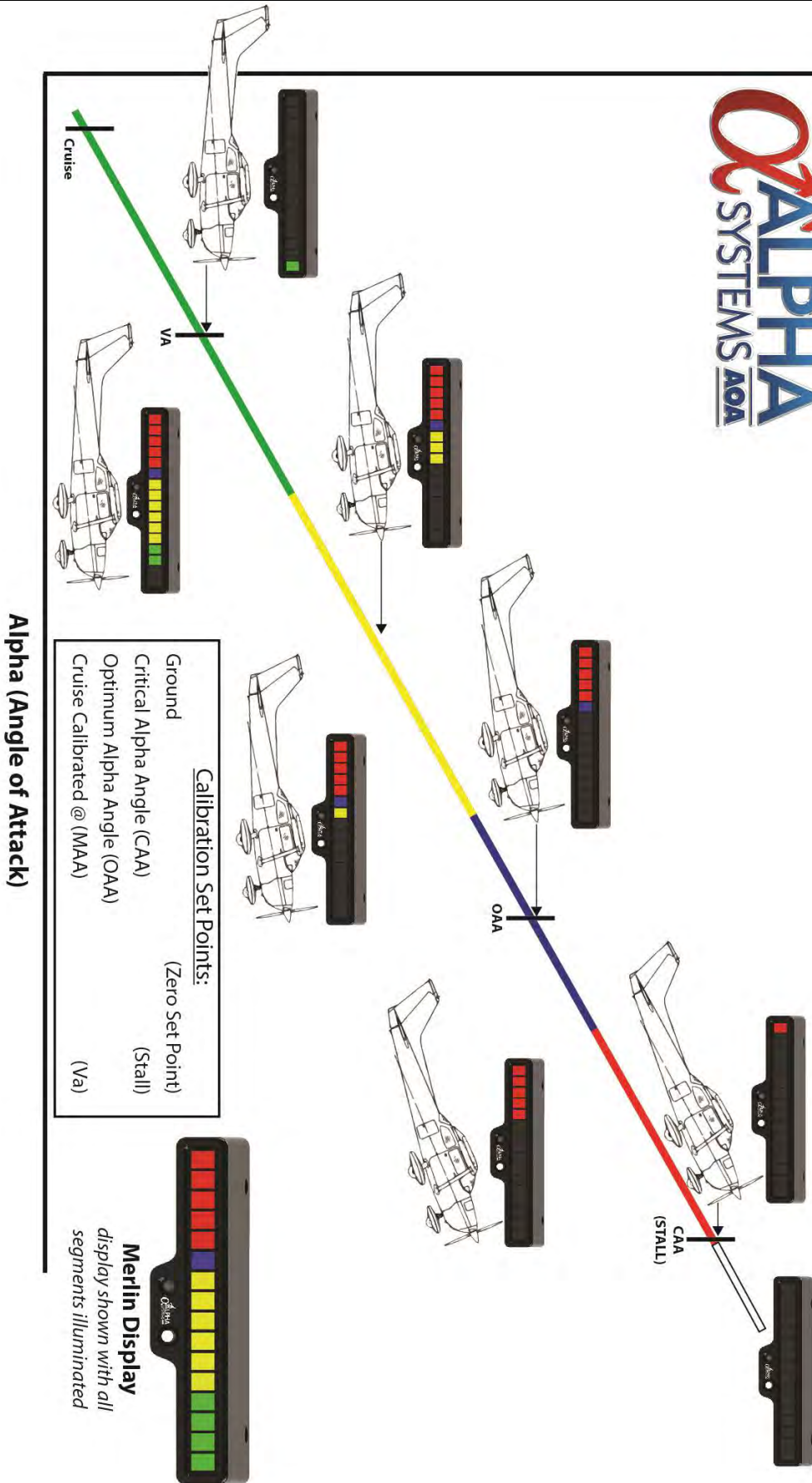

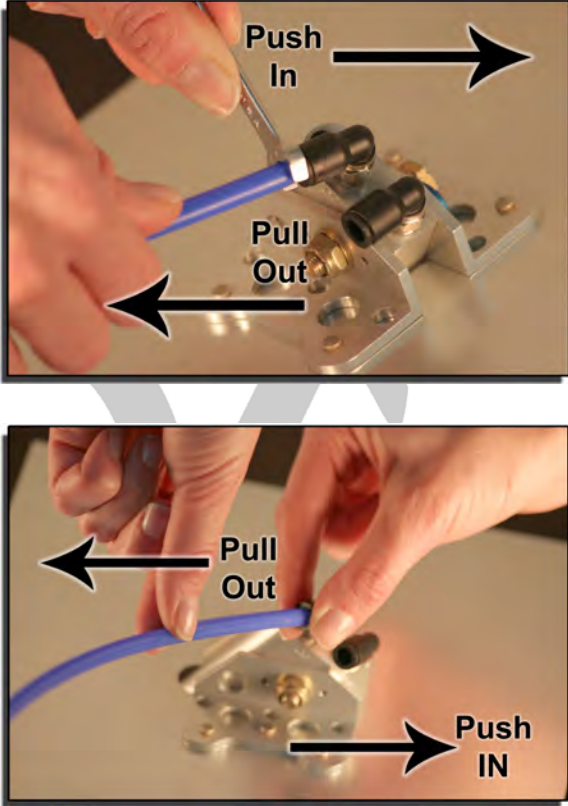

	<p>How to remove air tube from Quick-Release fittings:</p>
<p>Using a ¼” box end wrench, or your fingers, push down the release ring on the fitting and then pull air tube to remove.</p>	
<p>6180 140th Ave. N.W. Ramsey, MN 55303 www.alphasystemsaoa.com Tech Support Call: (763) 506-9990</p>	

Drawing Location: P:\Operations\DepotStar\Alpha Systems AOA\AOA WIRING DIAGRAMS 2014\AOA SYSTEM CONNECTION DIAGRAMS PDF\Merlin System Connection

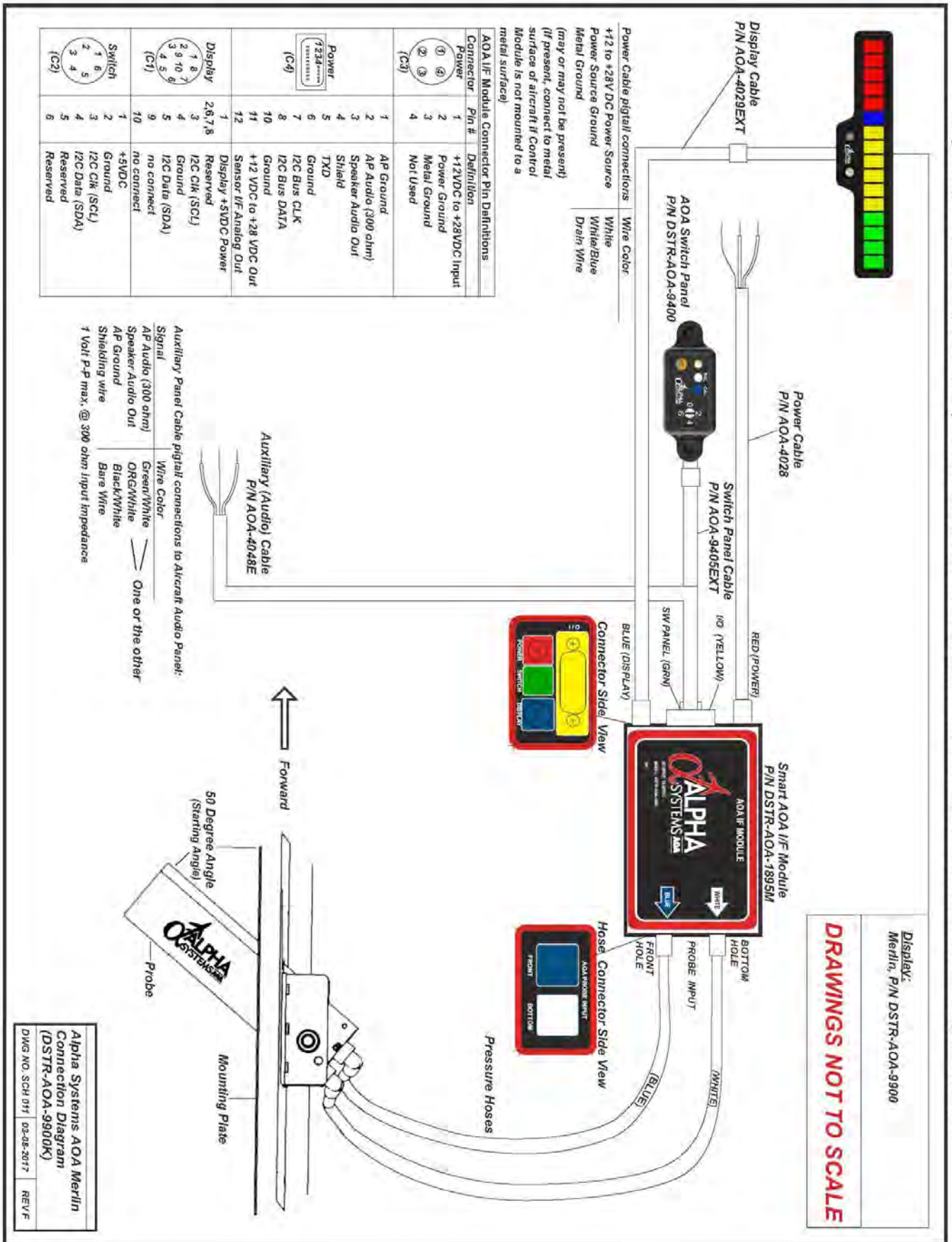

Drawing Location: P:\Operations\DepotStart\Alpha Systems AOA\AOA WIRING DIAGRAMS 2014\AOA SYSTEM CONNECTION DIAGRAMS PDFs\Merlin System Connection

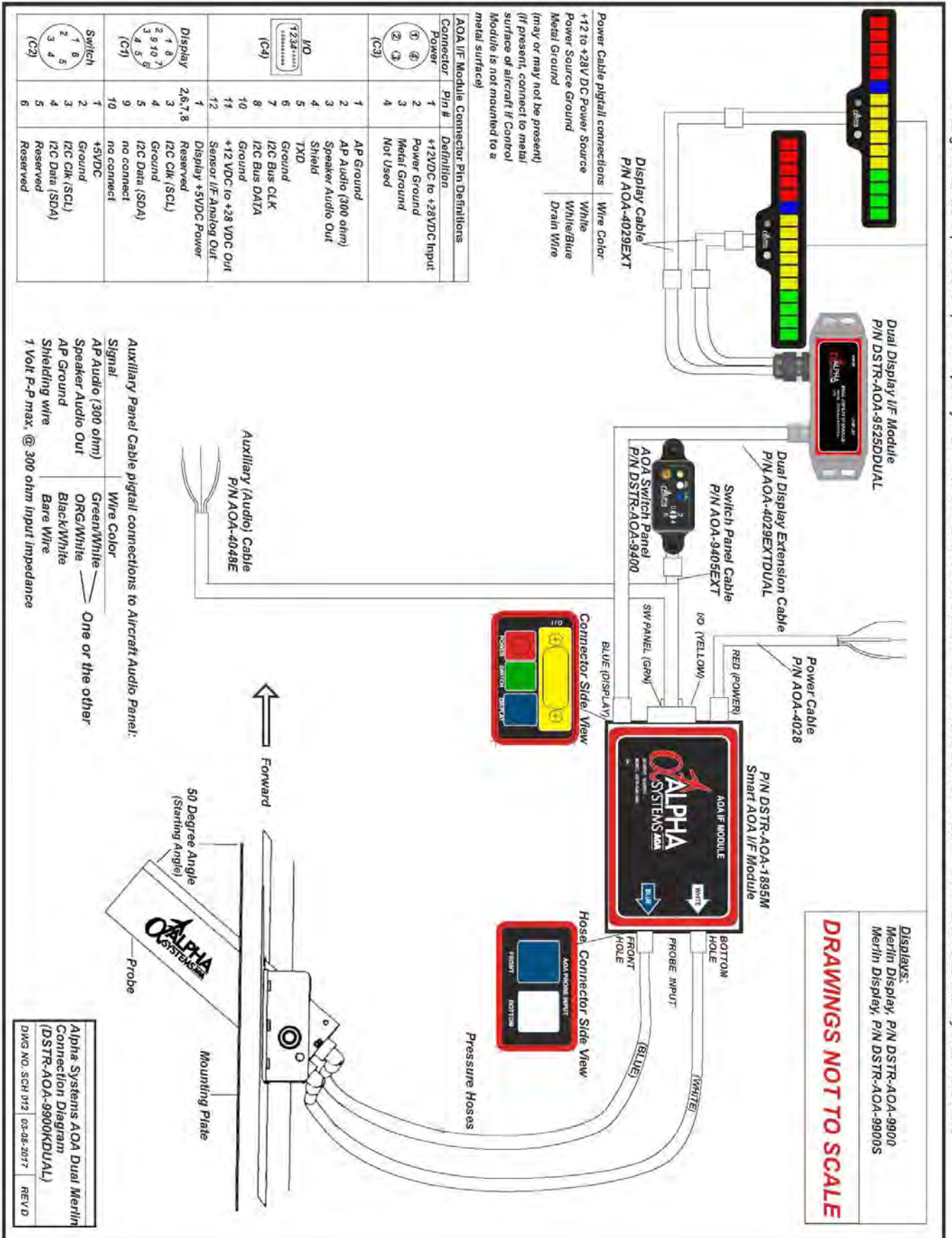

AOA I/F Module Connector Pin Definitions		
Connector	Pin # Definition	
Power (C-2)	1	+12VDC to +28VDC Input
	2	Power Ground
	3	Metal Ground
	4	Not Used
I/O (C-4)	1	AP Ground
	2	AP Audio (300 ohm)
	3	Speaker Audio Out
	4	Shield
	5	TXD
	6	Ground
	7	I2C Bus CLK
	8	I2C Bus DATA
	9	Ground
	10	+12 VDC to +28 VDC Out
Display (C-1)	1	Sensor I/F Analog Out
	2	Display +5VDC Power
	3	Reserved
	4	I2C CLK (SCL)
	5	Ground
	6	I2C Data (SDA)
	7	no connect
	8	no connect
	9	no connect
	10	no connect
Switch (C-3)	1	+5VDC
	2	Ground
	3	I2C CLK (SCL)
	4	I2C Data (SDA)
	5	Reserved
	6	Reserved

Auxiliary Panel Cable pigtail connections to Aircraft Audio Panel:

Signal	Wire Color
AP Audio (300 ohm)	Green/White
Speaker Audio Out	ORG/White
AP Ground	Black/White
Shielding wire	Bare Wire

1 Volt P-P max. @ 300 ohm input impedance

Alpha Systems AOA Dual Merlin Connection Diagram (DSTR-AOA-9900KDUAL)

DWG NO. SCH 012 | 03-08-2017 | REV D

Drawing Location: P:\Operations\DepotStar\Alpha Systems AOA\AOA WIRING DIAGRAMS 2014\AOA SYSTEM CONNECTION DIAGRAMS PDF\Merlin System Connection

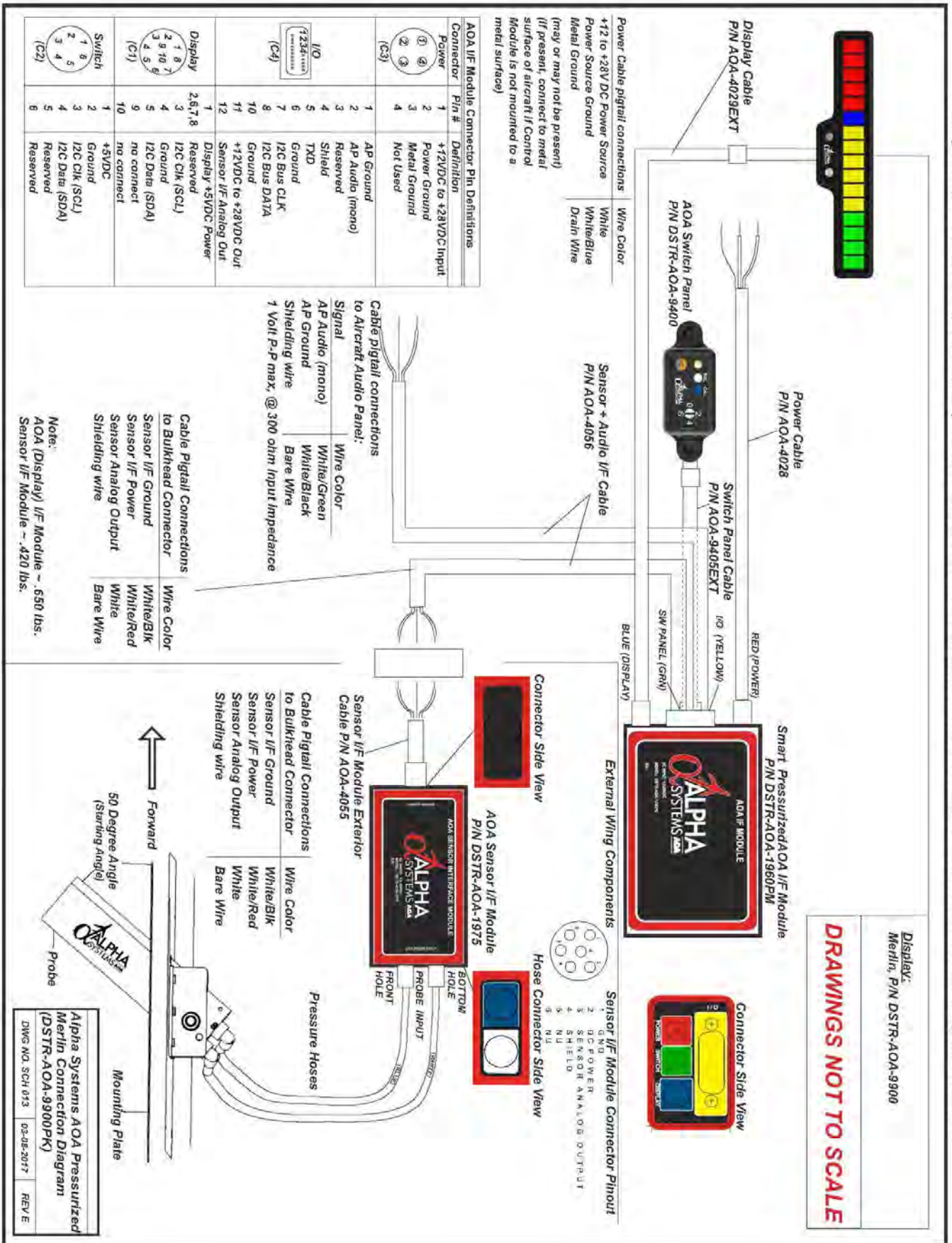

Drawing Location: P:\Operations\Depot\StarAlpha Systems AOA\AOA WIRING DIAGRAMS 2014\AOA SYSTEM CONNECTION DIAGRAMS PDF\Merlin System Connection

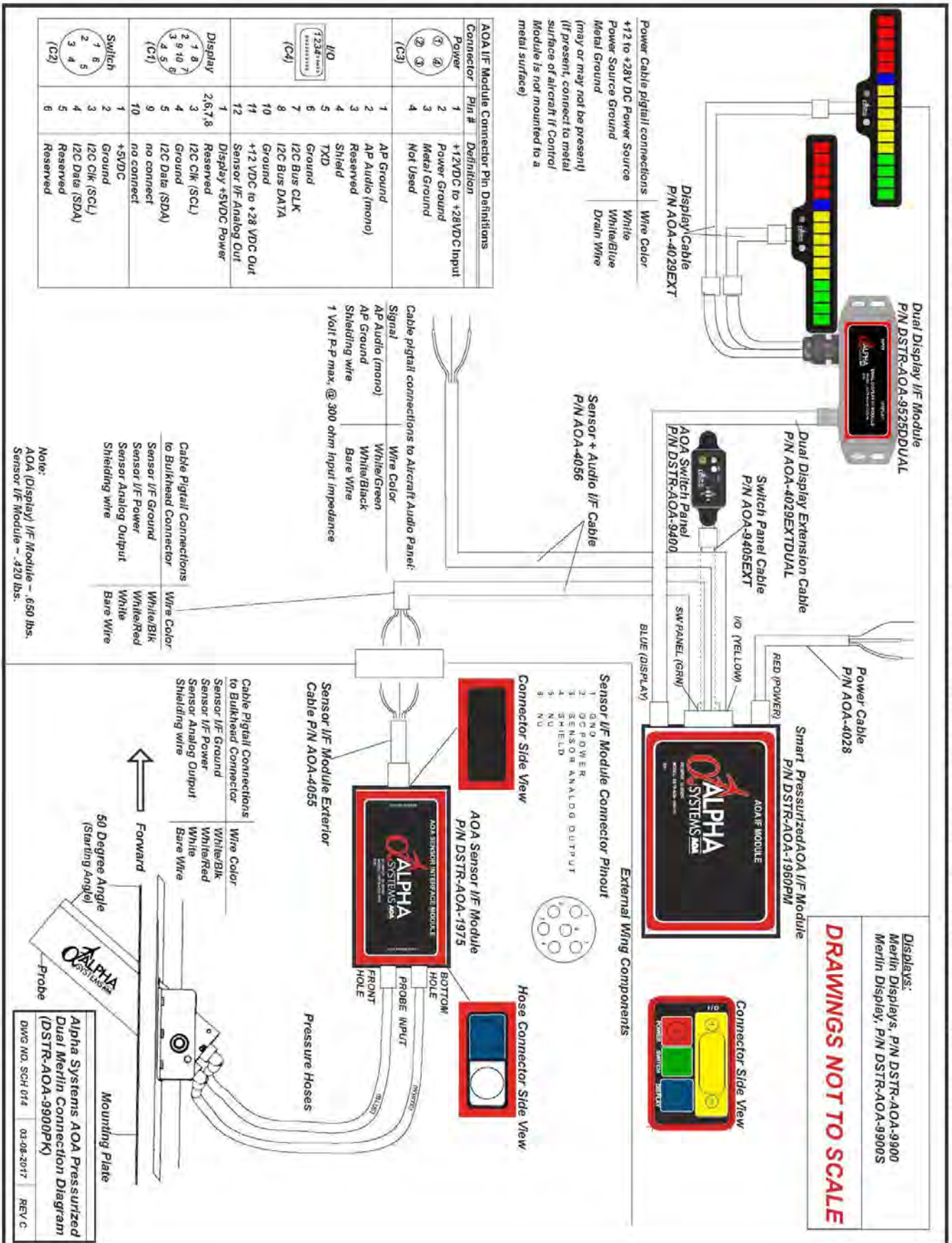

Pressurized Diagram

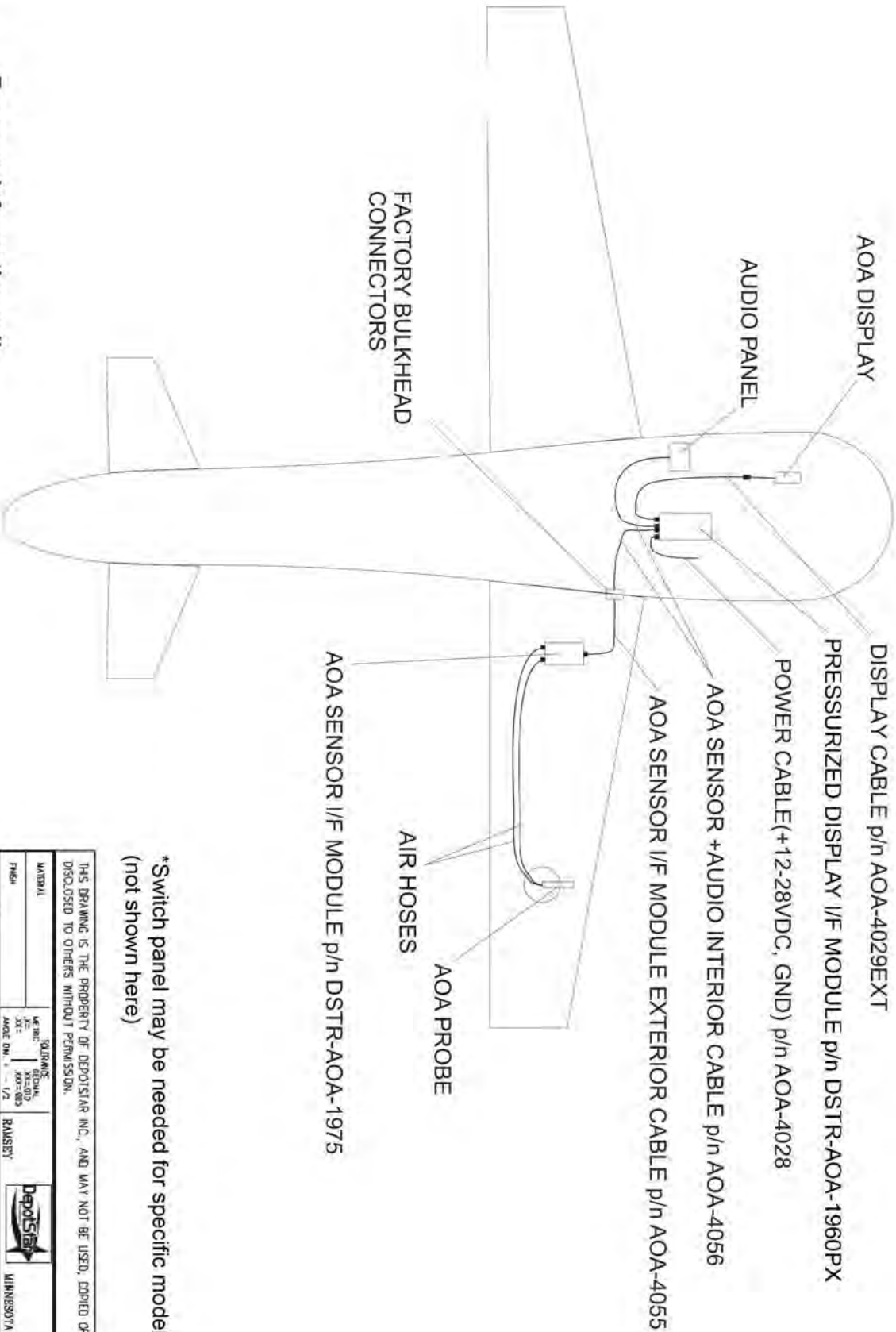

*Switch panel may be needed for specific models (not shown here)

For more information call
Alpha Systems AOA at 763-506-9990

THIS DRAWING IS THE PROPERTY OF DEPOSITAR INC., AND MAY NOT BE USED, COPIED OR DISCLOSED TO OTHERS WITHOUT PERMISSION.			
MATERIAL	ISO DIMENSIONS	DEPOSITAR	MINNESOTA
FINISH	MEASUREMENTS TOLERANCES	RAMSEY	
REF. DRAWINGS WHEN USED	MODEL NO. 000	TITLE	
	ECO NUMBER 0001	PRESSURIZED AOA SYSTEM WIRING DIAGRAM	
	DATE	SIZE	DRAWING NO.
	MRG	B	
NO. SHEET	CHECKED	SCALE	REV.
PAGE UNIT	N/A		B

Dual Pressurized Diagram

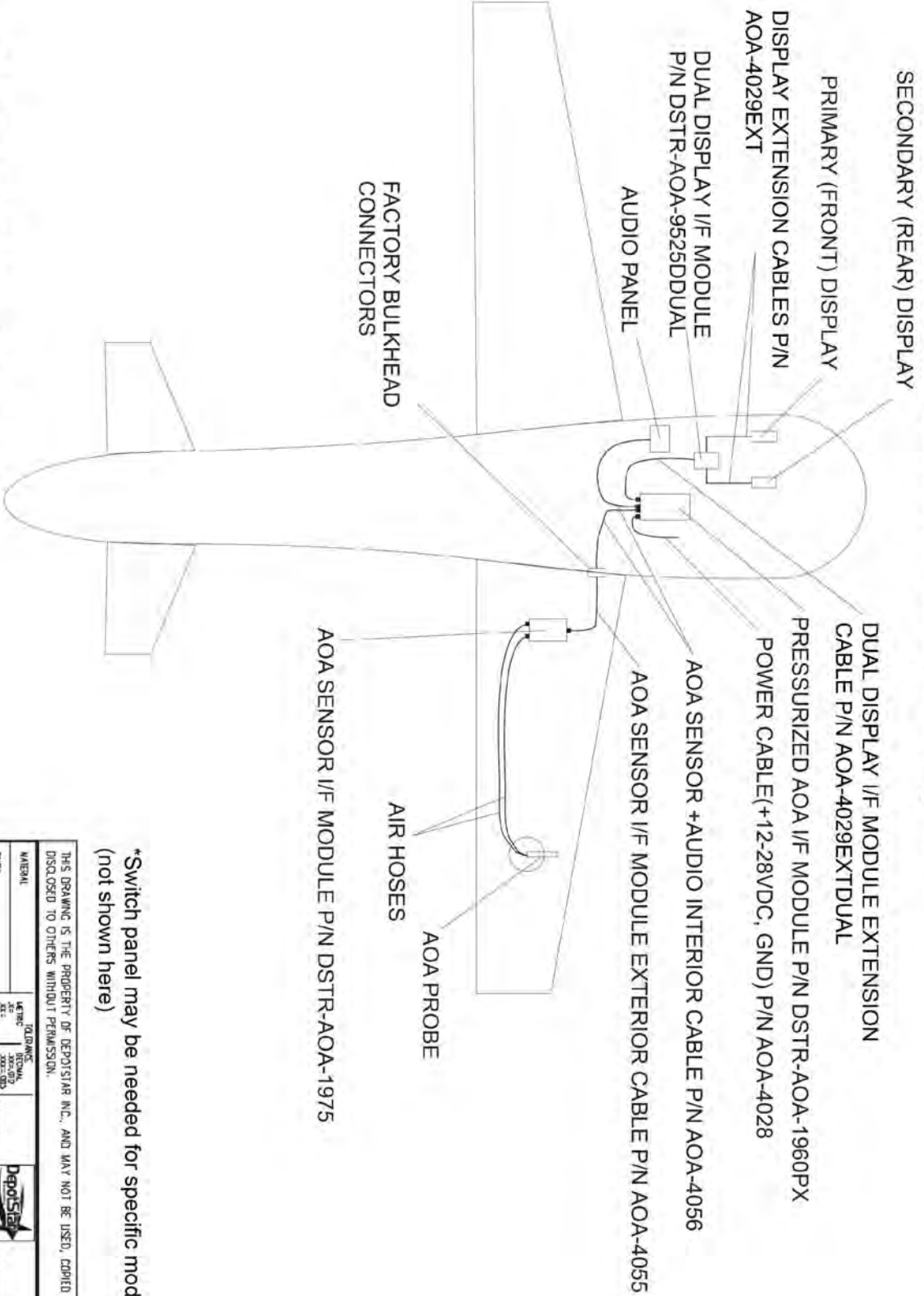

*Switch panel may be needed for specific models (not shown here)

For more information call
Alpha Systems AOA at 763-506-9990

MATERIAL				TOLERANCE				DepotStar		MINNESOTA	
FINISH				LETTERING SIZE X-HEIGHT ANGLE DIA. 1 - 1/2				RANGBY			
REF. DIMENSIONS NOT USED				ECD NUMBER 000				THE PRESSURIZED AOA SYSTEM WIRING DIAGRAM (Dual Display System)			
NO. FIELD P/N DIA				DRAWG. ST. DATE MFG. QW/15/15				SCALE N/A		REV. A	

THIS DRAWING IS THE PROPERTY OF DEPOTSTAR INC., AND MAY NOT BE USED, COPIED OR DISCLOSED TO OTHERS WITHOUT PERMISSION.

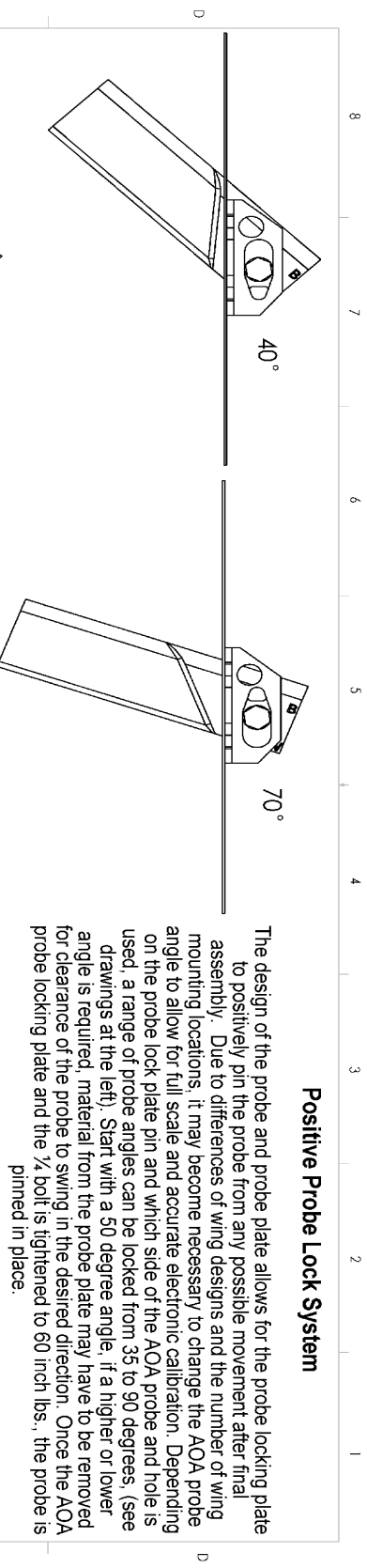

Positive Probe Lock System

The design of the probe and probe plate allows for the probe locking plate to positively pin the probe from any possible movement after final assembly. Due to differences of wing designs and the number of wing mounting locations, it may become necessary to change the AOA probe angle to allow for full scale and accurate electronic calibration. Depending on the probe lock plate pin and which side of the AOA probe and hole is used, a range of probe angles can be locked from 35 to 90 degrees. (See drawings at the left). Start with a 50 degree angle, if a higher or lower angle is required, material from the probe plate may have to be removed for clearance of the probe to swing in the desired direction. Once the AOA probe locking plate and the 1/4 inch bolt is tightened to 60 inch lbs., the probe is pinned in place.

LEFT SIDE INCREMENTS

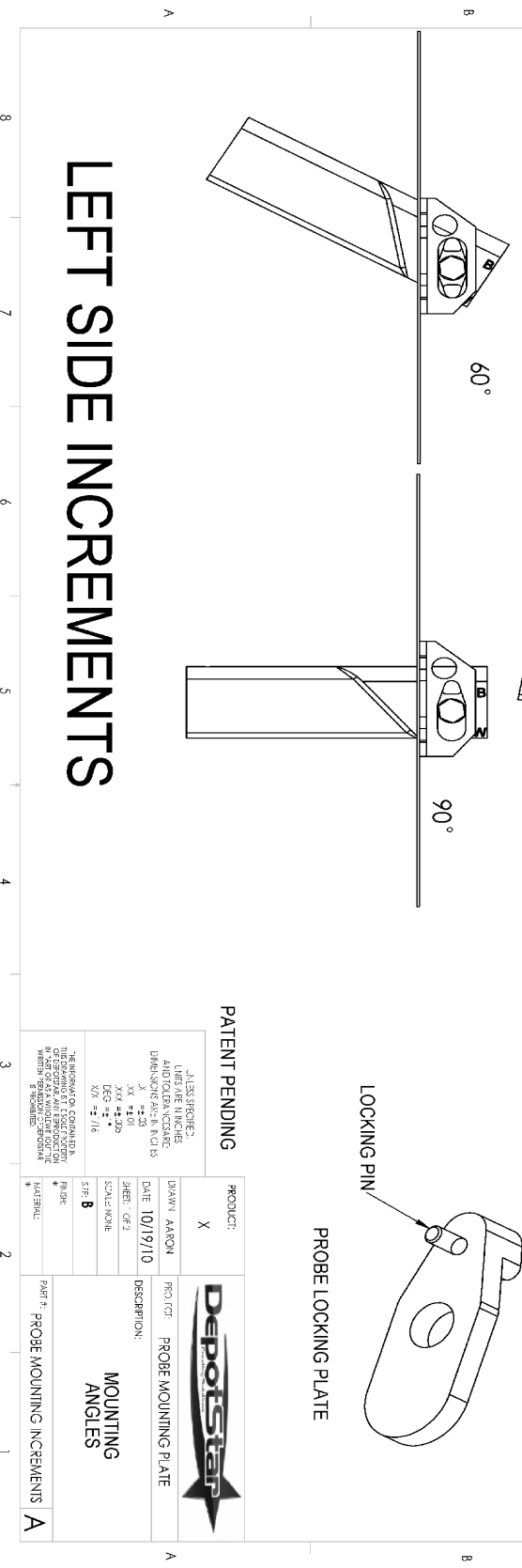

PATENT PENDING

ALL SIZE PROBER, LINES ARE IN INCHES AND DECIMALS THEREOF. DIMENSIONS ARE IN FIGURES XX - ±.01 XXX - ±.025 DEG - ±.1 X/A - ±.1/16	PRODUCT: X DESIGN: AARON DATE: 10/19/10 SHEET: OF 2 SCALE: NONE SFP: B	PROJ. COT: PROBE MOUNTING PLATE DESCRIPTION: MOUNTING ANGLES PART #: PROBE MOUNTING INCREMENTS A
--	---	--

Positive Probe Lock System

The design of the probe and probe plate allows for the probe locking plate to positively pin the probe from any possible movement after final assembly. Due to differences of wing designs and the number of wing mounting locations, it may become necessary to change the AOA probe angle to allow for full scale and accurate electronic calibration. Depending on the probe lock plate pin and which side of the AOA probe and hole is used, a range of probe angles can be locked from 35 to 90 degrees, (see drawings at the left). Start with a 50 degree angle, if a higher or lower angle is required, material from the probe plate may have to be removed for clearance of the probe to swing in the desired direction. Once the AOA probe locking plate and the 1/4" bolt is tightened to 60 inch lbs., the probe is pinned in place.

RIGHT SIDE INCREMENTS

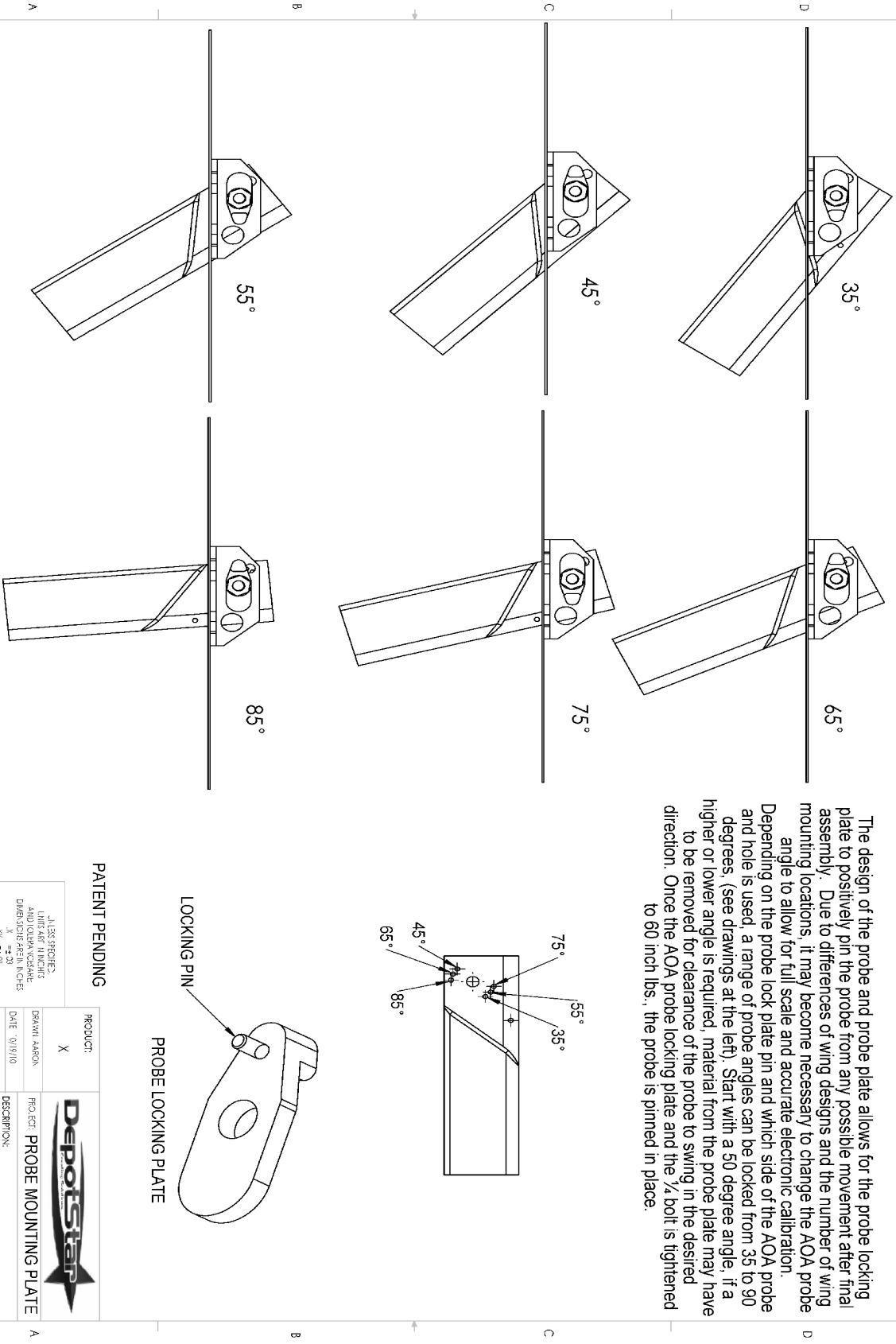

PATENT PENDING

JALISS SPECIES FAULT TOLERANCE DIMENSIONAL GREEN K-CHEE X # = 23 XX # = 01 DXA # = 206 DVA # = 1/16 X/Y # = 7/16 SEE B	DEKAWI AARON DATE: 01/19/10 SHEET 2 OF 2 SCALE: NONE FIGURE: B MATERIAL:	PROJ. ECT: PROBE MOUNTING PLATE DESCRIPTION: MOUNTING ANGLES PART #: PROBE MOUNTING INCREMENTS A
--	---	--

Switch Relay for AOA & Pitot Power

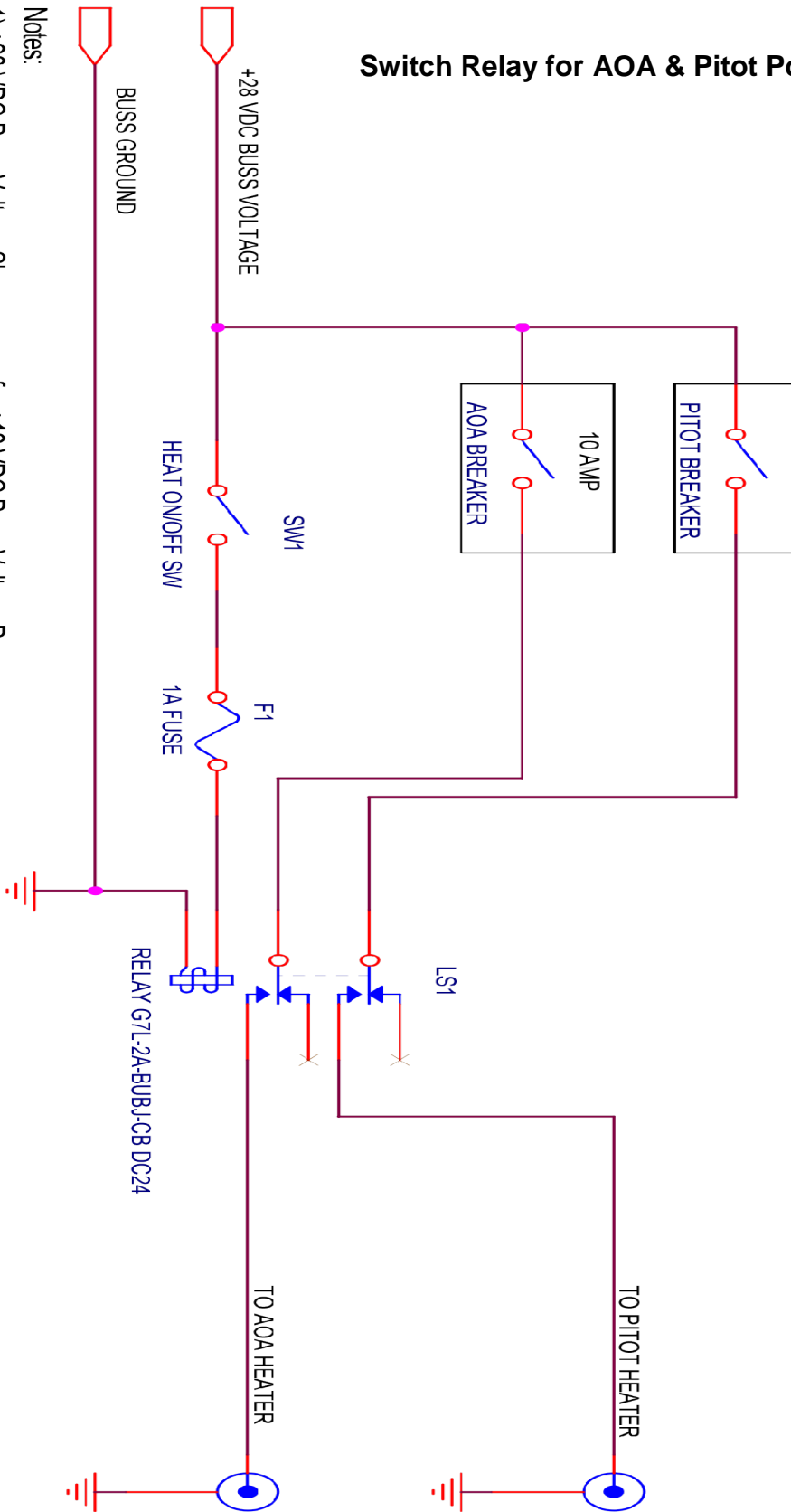

Notes:

- 1) +28 VDC Buss Voltage Shown, same for +12 VDC Buss Voltage Power
- 2) Relay circuit to turn on both Pitot and AOA Heat
- 3) Choose Fuses to fit Aircraft Panel

PROBE PLATE MOUNTING EXAMPLE

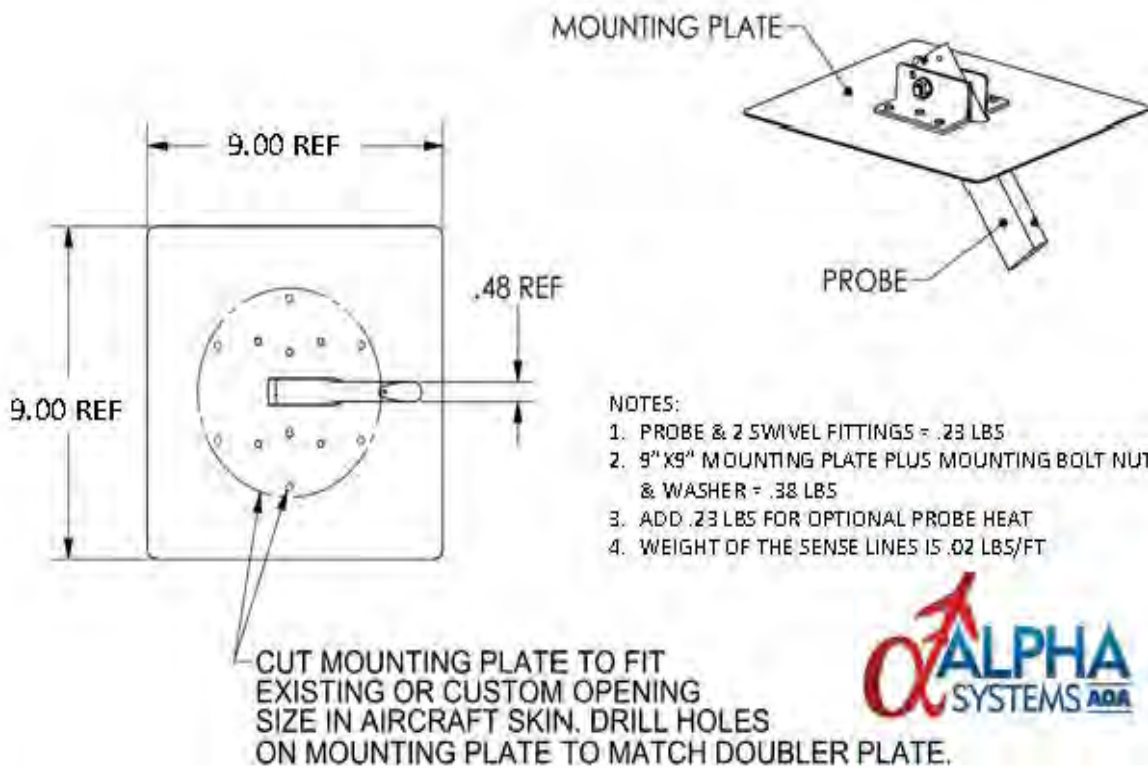
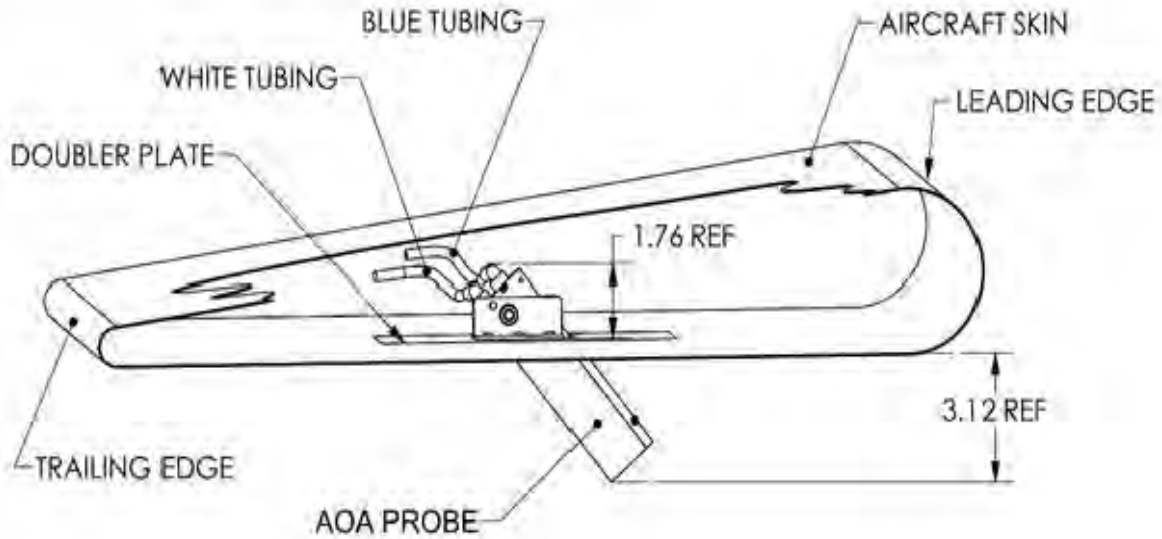

NOT TO SCALE

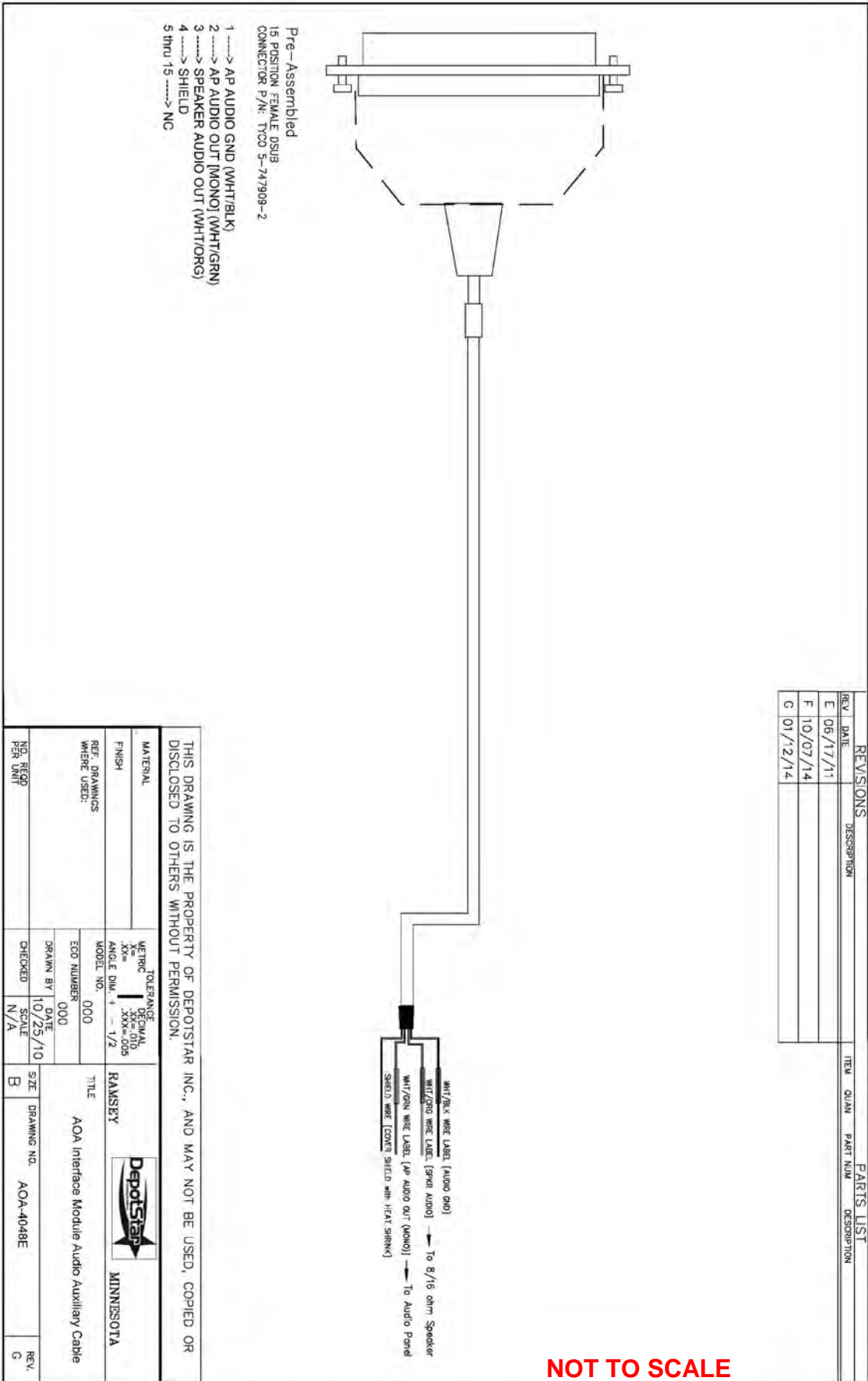

NOT TO SCALE

REAR VIEW OF CONNECTOR OR SOLDER VIEW

4 POSITION FEMALE HIROSE CONNECTOR P/N: HR10A-7P-4S(73)

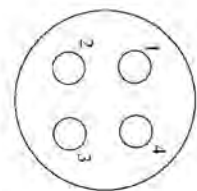

- 1 -----> WHITE WIRE (POWER)
- 2 -----> WHITE/BLUE WIRE (GROUND)
- 3 -----> NC
- 4 -----> NC

FRONT VIEW OF CONNECTOR

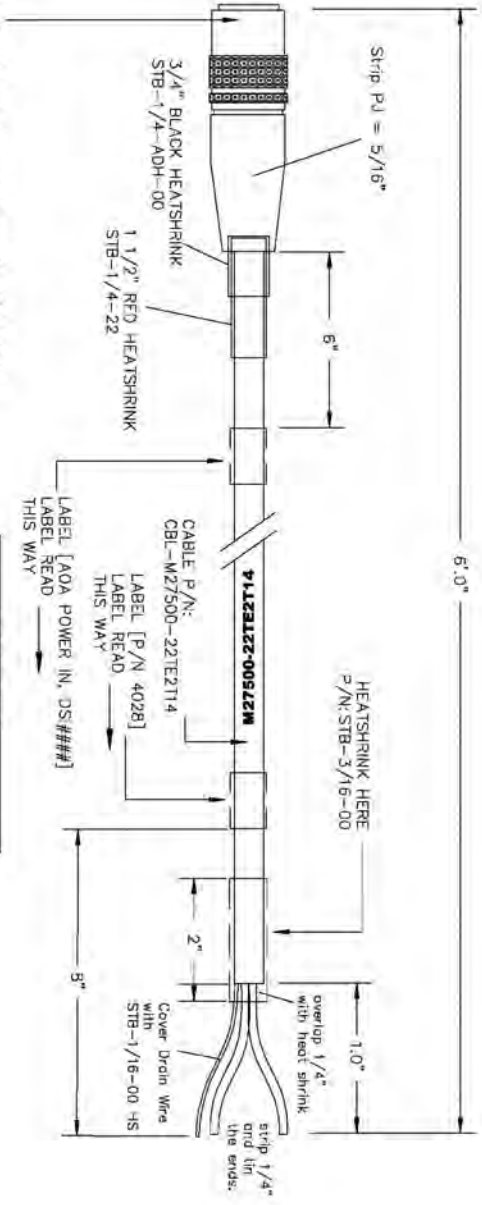
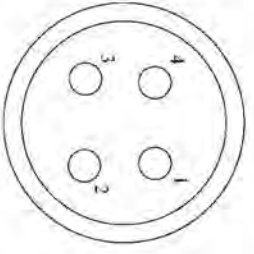

Strip cable jacket back to expose enough shield to be crimped under cable clamp.
 Put a drop of locite onto threads of the P shell and screw the plug body into the P shell.
 Plug the cable assembly into the torque fixture and tighten the p shell onto the plug using a modified torque wrench.
 Put a drop of locite on set screw.
 Tighten the set screw onto one of the bosses of the clamp and put on the cord bushing.

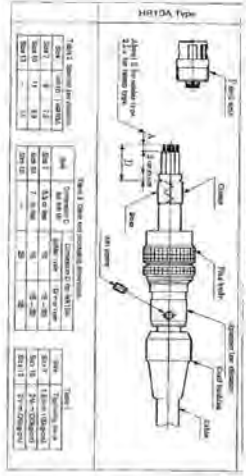

REVISIONS		PARTS LIST	
REV	DATE	DESCRIPTION	ITEM QUANTITY
K	12/19/14		

INSTRUCTIONS

CONNECTOR SIDE
 Put on in this order before soldering:
 1. AOA Power IN LABEL
 2. Rubber Boot
 3. 1/4" Adhesive Shrink Tubing (Black)
 4. 1/4" Shrink Tubing (Red)

THIS DRAWING IS THE PROPERTY OF DEPOTSTAR INC., AND MAY NOT BE USED, COPIED OR DISCLOSED TO OTHERS WITHOUT PERMISSION.

MATERIAL	TOLERANCE DECIMAL	RAMSEY	
FINISH	XX-010	AOA 1000 POWER CABLE	
REF. DRAWINGS WHERE USED:	MODEL NO. 000	SIZE	DRAWING NO. AOA-4028
ECO NUMBER	DATE	REV.	
NO. READ	SCALE		

NOT TO SCALE

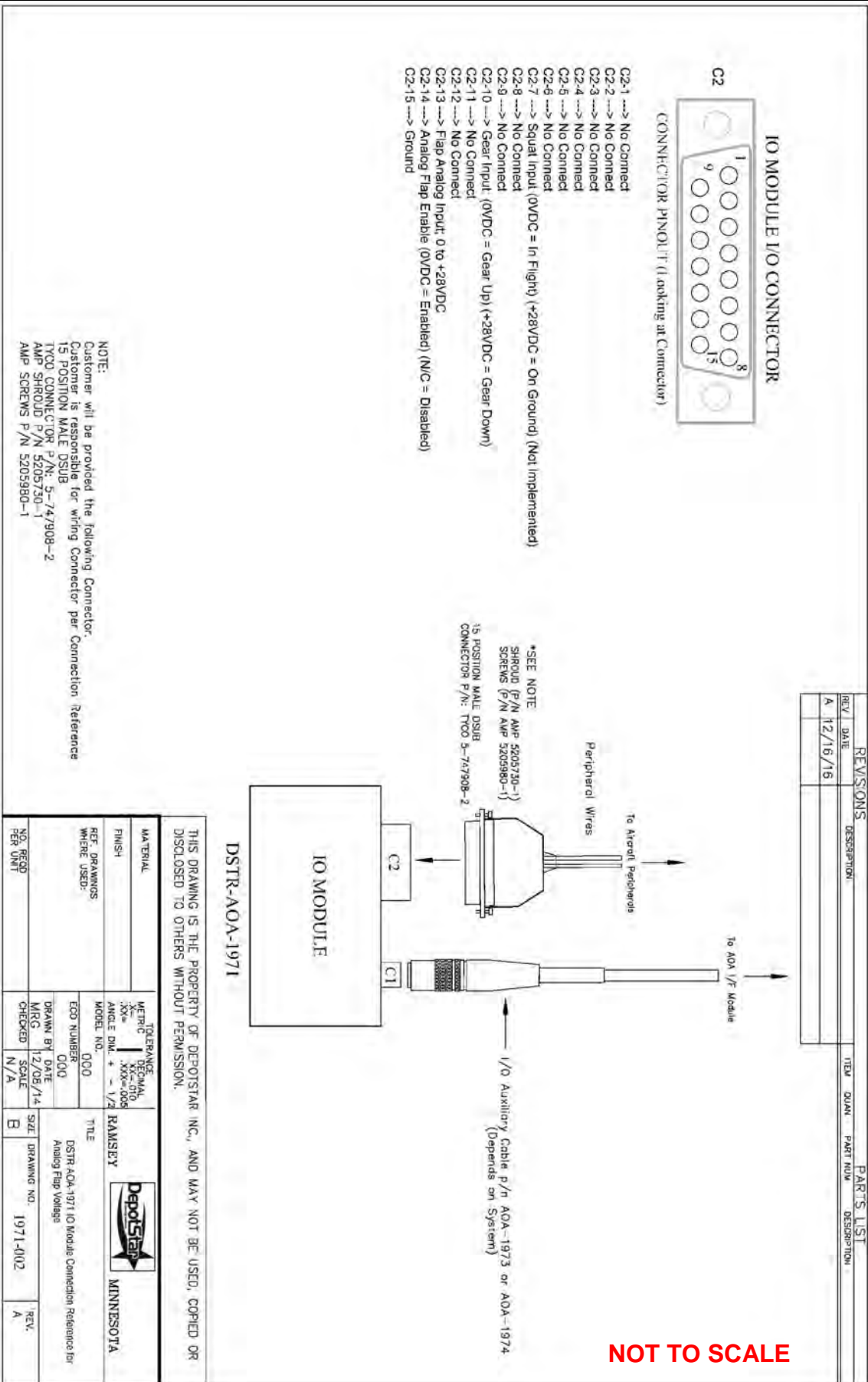

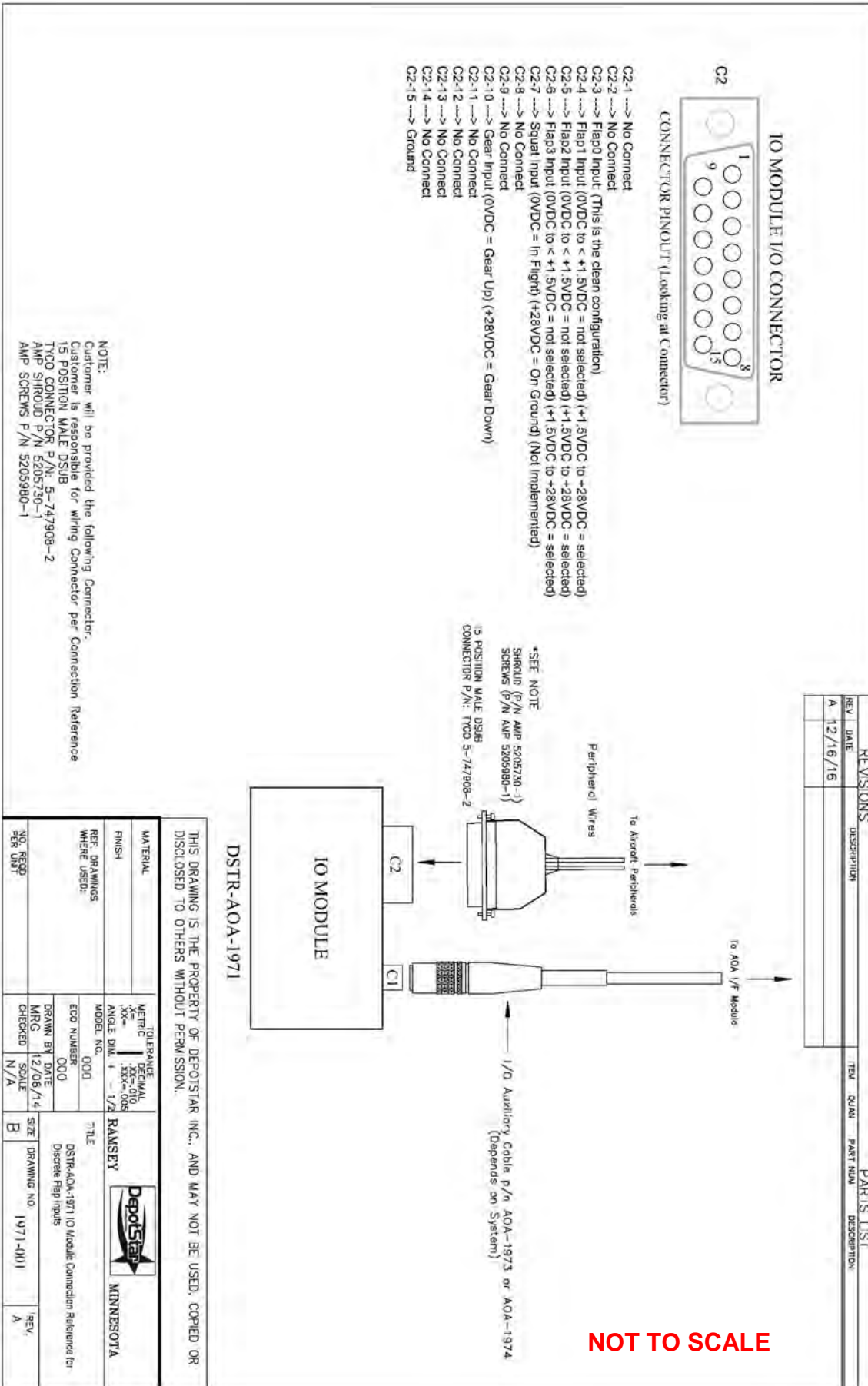

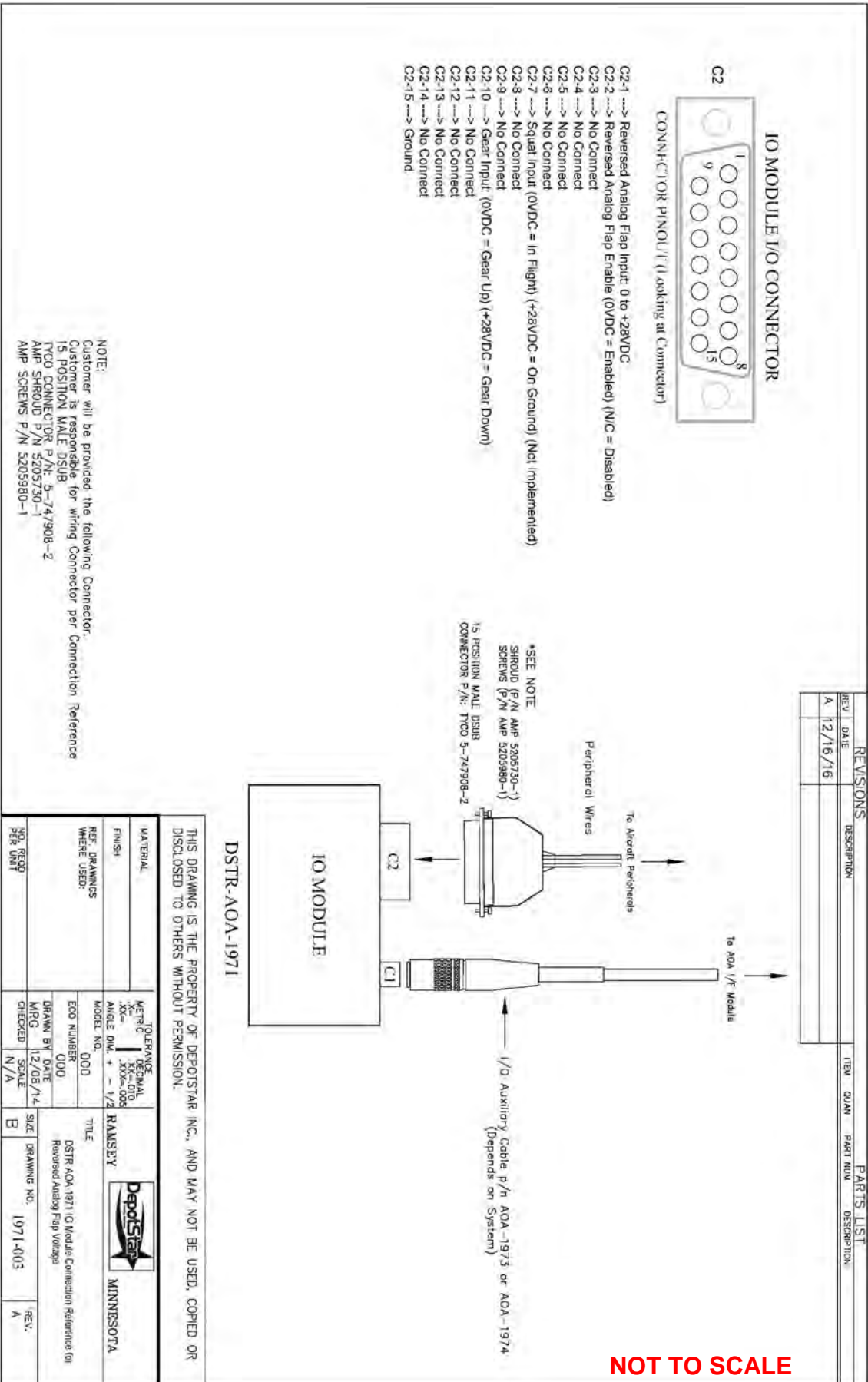

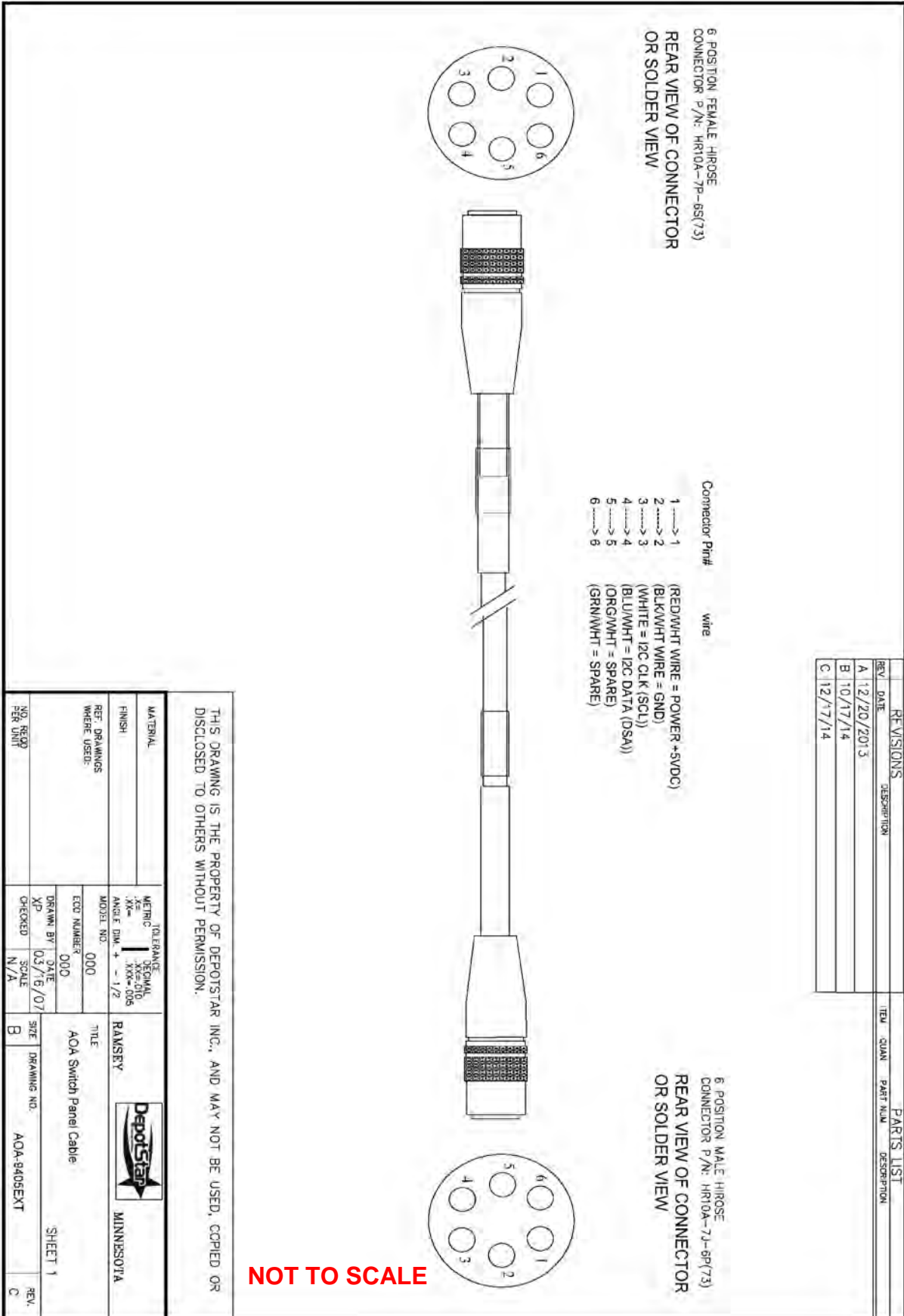

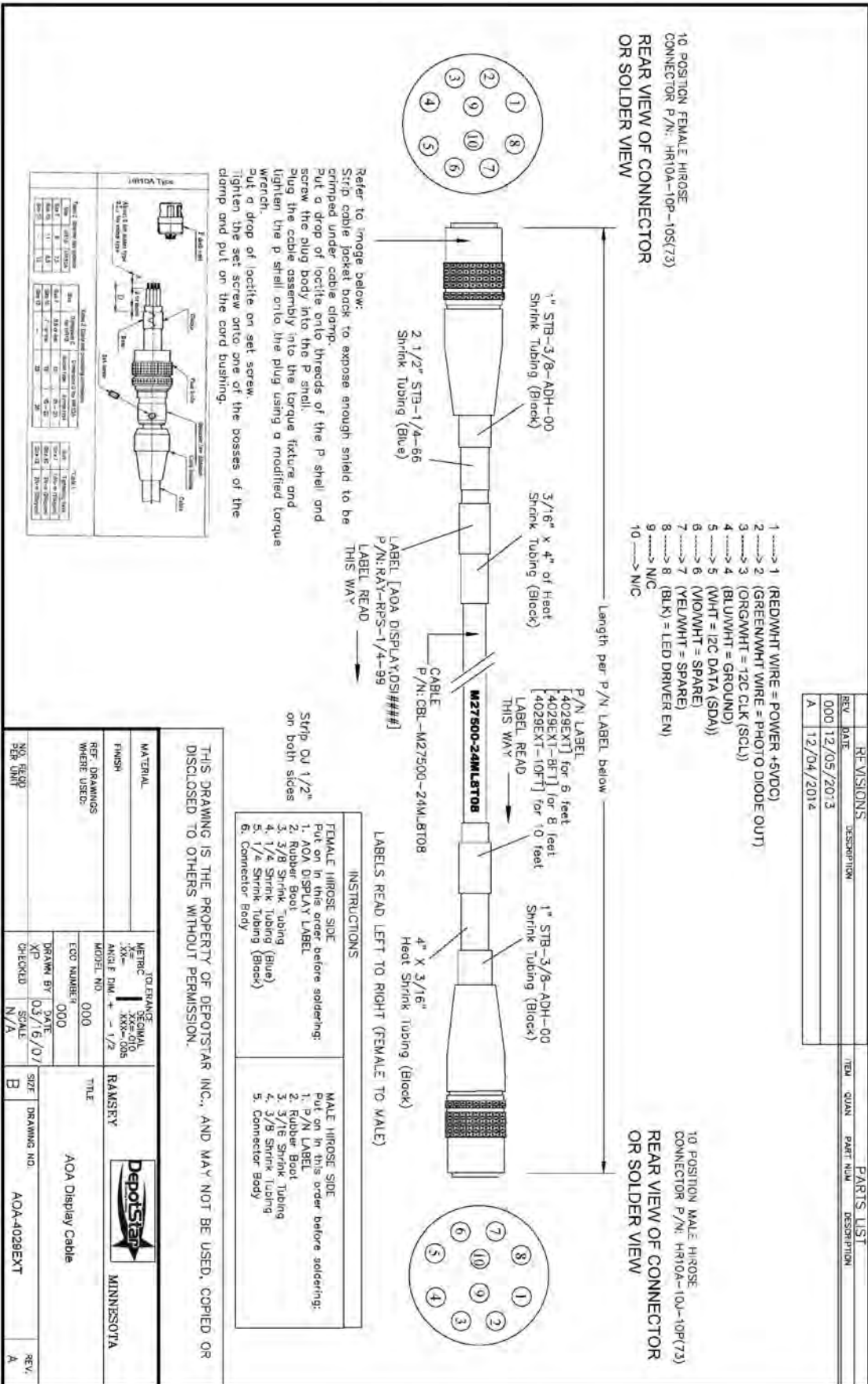



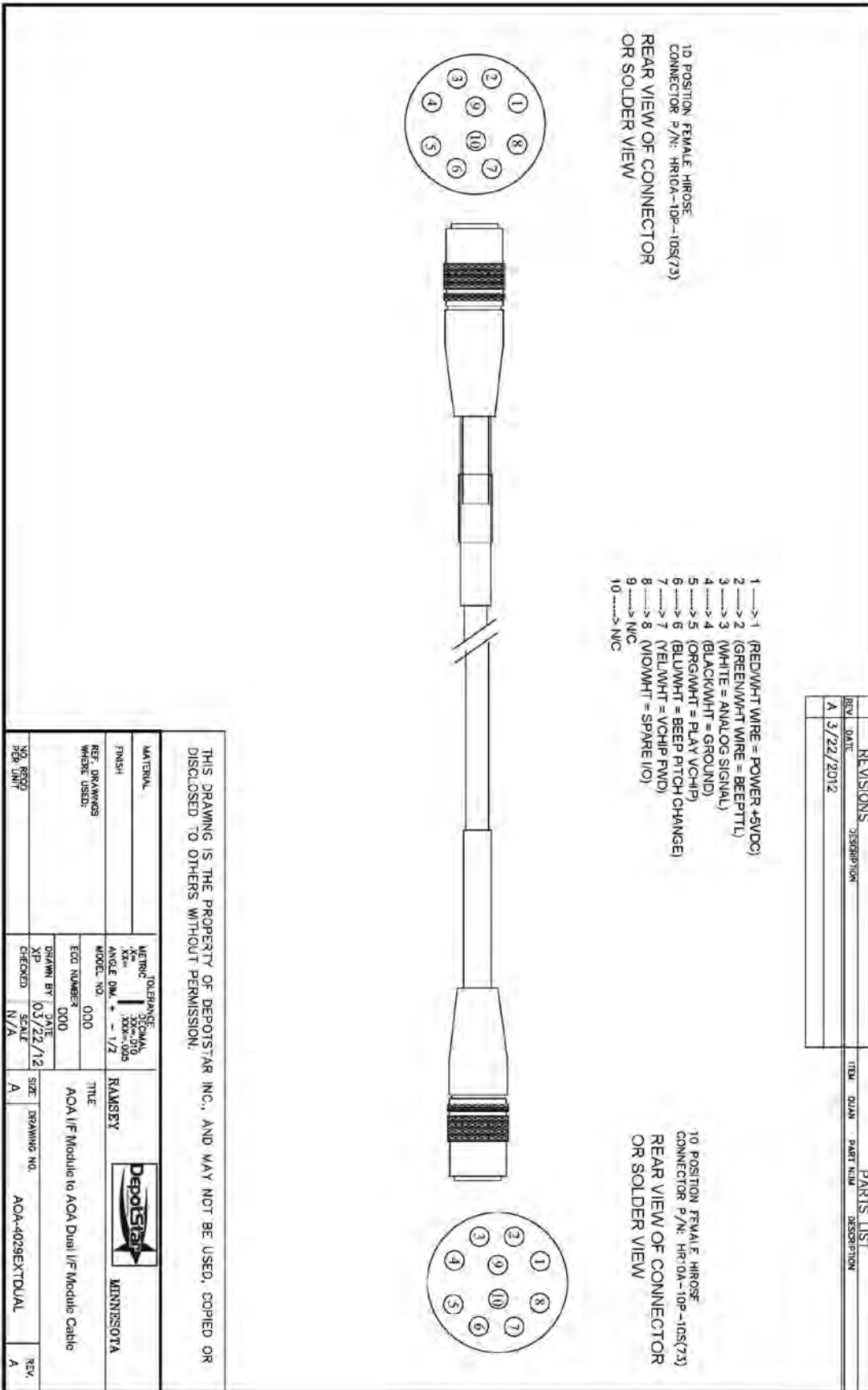

NOT TO SCALE







NOT TO SCALE

Alpha Systems AOA Merlin on the Ground Calibration Card



STEP	ACTION	AUDIO RESPONSE	DISPLAY RESPONSE
1. Ground, Zero Calibration - on ground, engine off, no airflow at AOA probe (clears all settings)			
	Turn system power OFF		
	Turn rotary switch to position 1		
	SEL button, press & hold		
	System Power ON	"Set Zero Offset"	 All LEDs flash
	CAL button, press	"Zero offset complete"	 Blue + green flash 5X
2. Brightness Calibration			
	Turn system power OFF		
	Turn rotary switch to position 3		
	SEL button, press & hold		
	Turn system power ON	"Set Brightness Levels"	 All LEDs ON
Set Daytime:	Light on Photocell, repeatedly press brightness button until desired level	"Maximum Brightness Reached"	Display cycles up through 16 levels of brightness then restarts at minimum level
Set Nighttime:	Cover Photocell, repeatedly press Brightness Button until desired level	"Maximum Brightness Reached"	Display cycles up through 16 levels of brightness then restarts at minimum level
At desired selection	Turn system power OFF		
3. Select Audio Type			
	Turn system power OFF		
	Turn rotary switch to position 5		
	SEL button, press & hold		
	Turn system power ON	"Set Audio Choice"	No display response
	CAL button, press	Cycles through 5 audio choices	
At desired selection	Turn system power OFF		

Alpha Systems Merlin AOA Calibration Flight Test Card

STEP	ACTION	AUDIO RESPONSE	DISPLAY RESPONSE
In-Flight Calibrations			
1. Optimum Alpha Angle (OAA) Vs x 1.3			
	System Power ON		
	Turn rotary switch to position 2		
	SEL button, press	"Set-point calibration on" "Set OAA set-point"	 Blue LED flash 3X approx. every 8 seconds
Fly @ identified Vs x 1.3 IAS (Hold Altitude)	On condition, press CAL	"OAA set-point complete"	 Blue LED ON & continues to flash 3X until Step 2
2. Cruise (weight adjusted Va, maneuvering speed)			
	SEL button, press	"set cruise set-point"	 Green LED flash 3X approx. every 8 seconds
	On condition, press CAL	"Cruise set-point complete"	 Green LED ON & continues to flash 3X until Step 3 completed
3. Save Settings & Exit			
	Turn rotary switch to position 0		
	SEL button, press	"Calibration off"	Display runs self-test
4. Set Flap Setpoints			
	Turn rotary switch to position 7		
	SEL button, press	"set Flap 1 (2) (3)"	Display remains active at current position
Fly Vs (Flaps #1) x 1.3 Fly Vs (Flaps #2) x 1.3 Fly Vs (Flaps #3) x 1.3	On condition, press CAL	"Flap 1 (2) (3) Complete"	 Blue LED ON
	Turn rotary switch to position 0		
	Turn system power OFF	"Calibration Off"	Display runs self-test
Repeat Step 4 for Flaps 2 and 3 if necessary			

Alpha Systems Merlin AOA Calibration Error Definitions

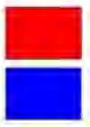
1	FAILURE	AUDIO RESPONSE	DISPLAY RESPONSE
<p>Ground, Zero Calibration - on ground, engine off, no airflow at AOA probe (clears all settings)</p> <p>Pressure - Too High</p>	<p>"Invalid set-point"</p>	<p>To isolate the failure between mechanical or electrical problems, the air hoses should be disconnected from the IM module (IM) and repeat steps 1-3 of section 1.5 in the operations manual.</p> <p>If the condition persists, then the failure is electrical and the IM should be returned for an authorized repair.</p> <p>If the setting is successful, the failure is mechanical, such as a blockage in the air hoses or AOA probe, etc. Identify the blockage and, once fixed, repeat steps 1-3 of section 1.5 in the operations manual.</p>	 <p>ALL LEDS FLASH CONTINUOUSLY</p>

2	In-Flight Calibrations	Optimum Alpha Angle (OAA) Vs x 1.3	
<p>Pressure - Too Low</p>	<p>"Invalid set-point"</p>	<p>If the pilot could not get a valid OAA value entered during the CAL button push and the display flashed BLUE and RED segments, the aircraft must be landed, and the AOA probe angle must be unpinned, rotated away from the leading edge of the wing 5 degrees and re-pinned, allowing the new angle to be secured and tightened. The in-flight OAA calibration procedure must be repeated.</p>	 <p>ERROR: FLASHES 3X THEN GOES DARK AND CONTINUES TO FLASH BLUE SEGMENT EVERY 5 TO 6 SECONDS UNTIL ACCEPTABLE VALUE IS ENTERED.</p>
<p>Pressure - Too High</p>	<p>"Invalid set-point"</p>	<p>If the pilot could not get a valid OAA value entered during the CAL button push and the display flashed a BLUE and YELLOW segments. The aircraft must be landed, and the AOA probe angle must be unpinned, rotated toward the leading edge of the wing 5 degrees, re-pinned and tightened. The OAA in-flight calibration procedure must be repeated.</p>	 <p>ERROR: FLASHES 3X THEN GOES DARK AND CONTINUES TO FLASH BLUE SEGMENT EVERY 5 TO 6 SECONDS UNTIL ACCEPTABLE VALUE IS ENTERED.</p>

3	Cruise (Va)	Pressure - Too Low	Pressure - Too High
	<p>"Invalid set-point"</p>	<p>If the pilot could not get a valid Cruise value entered and the display flashed the GREEN segment, the angle of attack was too high. Fly at weight corrected, Va speed and try the calibration again.</p>	<p>ERROR: FLASHES 3X THEN GOES DARK AND CONTINUES TO FLASH GREEN BAR EVERY 5 TO 6 SECONDS UNTIL ACCEPTABLE VALUE IS ENTERED.</p> 