



WHELEN AEROSPACE TECHNOLOGIES

Phone: (860) 526-9504
 Fax: (860) 526-2009
 Internet: www.flyWAT.com
 Sales/Service e-mail: info@flyWAT.com

Installation Guide/ICA:
Aviation model(s) OR6001G, OR6001R
P/N 01-0771733-01, 01-0771733-02
Orion 600 Wingtip PTA

TSO-C30c
 TYPE I, II & III;
 APPROVED

TSO-C96a
 CLASS II;
 APPROVED

The conditions and tests required for TSO approval of this article are minimum performance standards. Those installing this article either on or within a specific type or class of aircraft must determine that the aircraft installation conditions are within the TSO standards which include any accepted integrated non-TSO functions. TSO articles and any accepted integrated non-TSO function(s) must have separate approval for installation in an aircraft. The article may be installed only according to 14 CFR part 43 or the applicable airworthiness requirements.

SPECIFICATIONS:

Nominal Operational Voltage:12VDC
 (Operational from 9-14VDC)
Input Current:
 Position Lights0.48 Amps
 Anti-Collision Light (Avg.)1.0 Amps
 Anti-Collision Light (Pulse)5.2 Amps
 Flashrate45 ± 5 FPM

EQUIPMENT LIMITATIONS:

An approved forward position lighting system consists of two lights, one located on each wingtip. The baseplate must be mounted parallel to the vertical and horizontal centerlines of the aircraft to project the patterns properly. Certain types of installations may require additional testing.

AIRWORTHINESS LIMITATIONS:

The Airworthiness Limitations section is FAA approved and specifies inspections and other maintenance required under §43.16 and §91.403 of the Federal Aviation Regulations, unless an alternative program has been approved.

No airworthiness limitations are associated with the installation of the LED position/anti-collision light.

CONTINUED AIRWORTHINESS:

The forward position light is designed with Green LEDs or Red LEDs. The tail position light is designed with 2 White LEDs. The anti-collision light is designed with 24 White LEDs. If any one LED fails, the unit must be repaired or replaced.

Inspect the lens, replace if there is excessive scratching, pitting, discoloration or cracking. For additional lens maintenance detail see SAE ARP5637.

Note: To reduce eye strain, use an optical filter such as dark glasses or a blue covering dome during LED inspection.

PERIODIC INSPECTIONS:

An annual inspection shall be performed unless the OEM specifies a shorter interval.

INSTALLATION PROCEDURES:

The following information is to assist you in installing a WAT light system. The installation procedure described in the following text will be confined to a single light installation, but is identical for multiple light installations.

1. Choose the appropriate light assembly.
2. Using the mounting detail information provided, prepare the aircraft for means to secure the light assembly.
3. Carefully remove the #2 cap head screws and lens retainer. Remove the lens from the light assembly by lifting the rear of the lens approximately 1/2". Now slide the lens rearward approximately 1/2" and lift upwards to remove. **CAUTION! Do not touch the LED lens surface with either fingers or sharp objects. This could soil and/or damage the lens and affect the optical performance of the LEDs.** Remove the 3 black Phillips head screws securing the baseplate to the light assembly. Remove baseplate.
4. Using the appropriate hardware install the baseplate to the aircraft.
5. Connect the light inputs according to the chart shown. Connect the power lead to an appropriately sized breaker. Connections to be according to FAA approved methods.

Note: SYNC is a low-power, bi-directional control signal. Connecting to the synchronize signal of any WAT LED anti-collision assembly to another WAT anti-collision assembly will cause the lights to flash at the same time. If Synchronization is not necessary, the connection may be left open.

6. Re-install the light assembly on to the baseplate and insure that all leads are clear of any obstructions and secured as required. Note that proper orientation is achieved with the drain hole down.
7. Install lens in the reverse order as removal, return the lens retainer to its installed location, re-insert #2 cap head screw and tighten firmly. Confirm proper gasket fit.
8. When necessary, waterproof the light base to aircraft. Apply single-part Silicone (RTV) or equivalent around any open area where water could get in. Do not cover the drain hole.
9. Check all avionics systems for interference from this installation.
10. A flight check should be performed by a properly certified pilot.
11. If required, update aircraft records utilizing FAA Field Approval (Form 337) or equivalent.

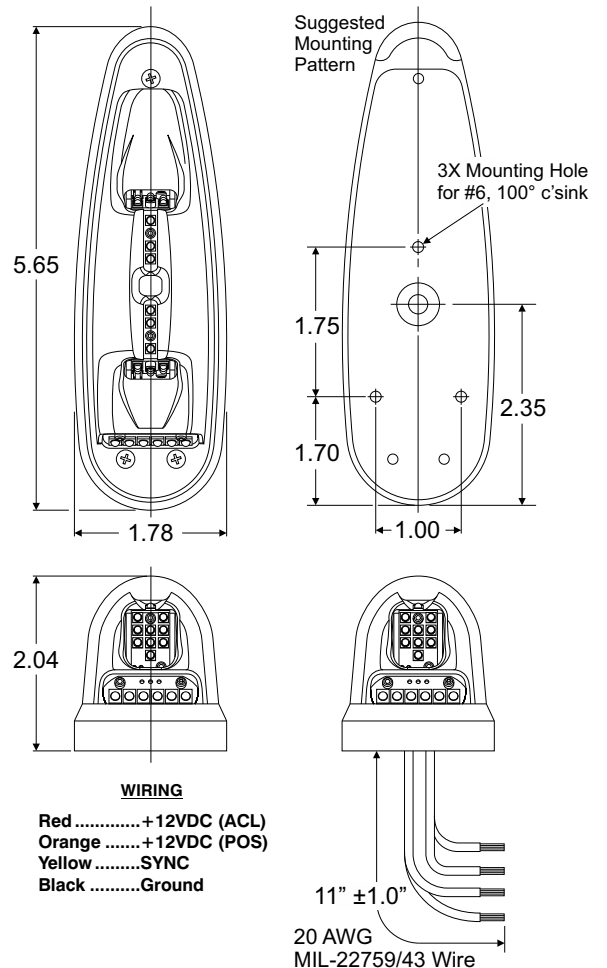

Aviation

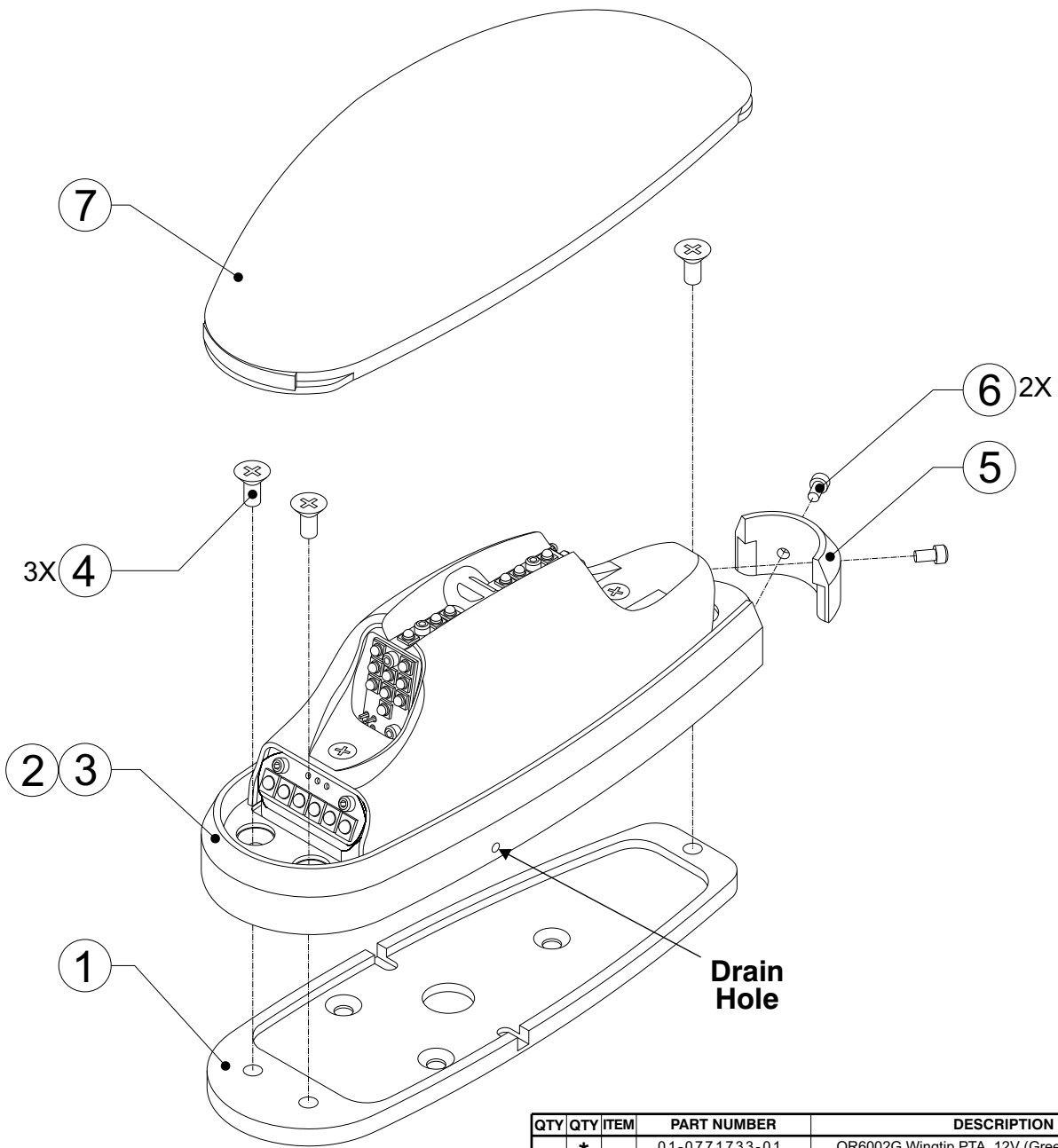

| QTY | QTY | ITEM | PART NUMBER | DESCRIPTION |
|-----|-----|------|---------------|---------------------------------------|
| | * | | 01-0771733-01 | OR6002G Wingtip PTA, 12V (Green) |
| * | | | 01-0771733-02 | OR6002R Wingtip PTA, 12V (Red) |
| 1 | 1 | 1 | 06-171708-001 | Baseplate |
| - | 1 | 2 | _____ | OR6001 Assembly (GREEN) |
| 1 | - | 3 | _____ | OR6001 Assembly (RED) |
| 3 | 3 | 4 | 14-0050581B03 | Screws, 4-40 x 5/16 P100FH MS24693-3B |
| 1 | 1 | 5 | 19-171730-00 | Retainer, Lens |
| 2 | 2 | 6 | 14-026A36-04M | Screws, 2-56 x 1/4 Socket HP Cap |
| 1 | 1 | 7 | 02-0371773-30 | Lens, Clear, Hardcoated |