



OWNER'S MANUAL

SAVE THESE INSTRUCTIONS

PRO20-115 PRO20-115RD 115-Volt AC

- PRO20-115AD** Automatic Diesel Nozzle
- PRO20-115MD** Manual Diesel Nozzle
- PRO20-115PO** Pump Only
- PRO20-115RD** For Remote Dispensing Systems
- PRO20-115PO/XTS** Pump Only - Extreme Temperature Series

PRO20-230 230-Volt AC

- PRO20-230AD** Automatic Diesel Nozzle
- PRO20-230MD** Manual Diesel Nozzle
- PRO20-230PO** Pump Only



DO NOT RETURN THIS PRODUCT TO THE STORE!

Please contact Great Plains Industries before returning any product. If you are missing parts or experience problems with your installation, our Customer Support Department will be happy to assist you:

800-835-0113 or **316-686-7361**

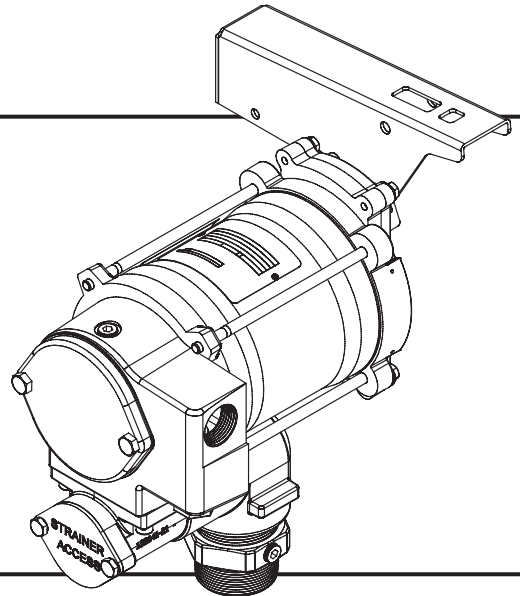

TABLE OF CONTENTS

General Information.....	2
Installation	2
Operation.....	4
Maintenance.....	4
Troubleshooting.....	5
Illustrated Parts Drawing	6
Specifications	7
Parts and Service	7
Warranty	See Insert

To the owner...

Congratulations on receiving your GPRO™ Fuel Transfer Pump. We are pleased to provide you with a system designed to give you maximum reliability and efficiency.

Your fuel pump is designed, tested, and approved for use with most thin viscosity petroleum fuels. Please take all due precautions when handling flammable liquid fuels. Your safety is important to us.

Also, to assure the longest possible service life, it is important that you follow the operation and maintenance procedures outlined in this manual. We are proud to provide you with a quality product and dedicated support. Together with your conscientious use, we are sure that you will obtain years of safe, dependable service.



Victor Lukic

Victor Lukic, President
Great Plains Industries, Inc.

EXPLANATION OF ISO SAFETY SYMBOLS



This symbol indicates a general warning to the user. See additional specific warnings.



This symbol indicates electrical shock hazard. Follow proper installation and maintenance instructions in this manual.



This symbol indicates hot surface. Take care to avoid coming into contact with hot surface.



This symbol indicates automatic restart. Pump contains thermal protection which automatically shuts off motor before overheating. Pump will turn back on automatically after cooling. Turn switch OFF and wait 30 minutes to resume normal pumping. Disconnect power before any inspection or service.



Owner's manual must be read before using, inspecting, or servicing this product.



Disconnect power when product is unattended or in the case of a malfunction. Disconnect power before any inspection, servicing, or maintenance.



Smoking, open flames, fires, and open ignition sources are prohibited in the vicinity of this product.

AVIATION FUELING

"Pump Only" models sold without a hose or nozzle are approved for ground-based refueling only. Do not use in or on aircraft. User must provide hose, suction pipe, nozzle, and accessories that meet the appropriate NFPA 407 Standard for Aircraft Fuel Servicing. Pumps have no actual or implied compliance with this standard. Please consult NFPA 407 for recommended safety requirements during ground fuel servicing of aircraft using petroleum fuels.

GENERAL INFORMATION

Your pump is designed for use with thin viscosity petroleum fuels such as gasoline blends (up to E15), diesel blends (up to B20), and kerosene. Additionally, "Pump Only" models (sold without a hose and nozzle) are compatible with aviation gasoline AVGAS 100LL and kerosene grade Jet A. Dispensing any fluids other than those for which it was designed can damage components and void the warranty.

Model Components

PRO20-115AD/ PRO20-230AD: Includes pump, hose, automatic diesel nozzle and components to assemble to unit before use.

PRO20-115MD/ PRO20-230MD: Includes pump, hose, manual diesel nozzle and components to assemble to unit before use.

PRO20-115PO / PRO20-230PO: Includes pump only and components to assemble to unit before use.

PRO20-115RD: Includes dedicated pump only for remote dispensing systems.

PRO20-115PO/XTS: Includes pump only and components to assemble to unit before use.

NOTE: Suffixes MD, AD, PO and PO/XTS are for ordering purposes only. Constructions described above are covered as alternate constructions under the Part No. PRO20-115 and PRO20-230 UL Listing.

SAFETY INSTRUCTIONS



The following safety alert symbols are used in this manual. Obey all safety messages that follow this symbol to avoid possible injury or death.

DANGER

DANGER indicates an imminently hazardous situation which, if not avoided, will result in death or serious injury.

WARNING

WARNING indicates a potentially hazardous situation which, if not avoided, could result in death or serious injury.

CAUTION

CAUTION indicates a potentially hazardous situation which, if not avoided, may result in minor or moderate injury.

CAUTION

CAUTION used without the safety alert symbol indicates a potentially hazardous situation which, if not avoided, may result in property damage.

There are inherent dangers wherever flammable fuel and AC electrical sources are in close proximity.

Static electricity as a source of sparking is always a con-

cern and requires extreme care in the installation and operation of your entire fuel transfer system.

Additional components such as meters, automatic nozzles and filters must be listed for use with fuel transfer systems. The flow of fuel through a hose and nozzle can generate static electrical charges and dangerous sparking can result in fire or explosion. Hoses and nozzles must be electrically conductive and bonded to ground.

It is your responsibility to:

- Know and follow applicable national, state and local safety codes pertaining to installing and operating electrical equipment for use with flammable liquids.
- Know and follow all safety precautions when handling petroleum fuels.
- Ensure that all equipment operators have access to adequate instructions concerning safe operating and maintenance procedures.

INSTALLATION

WARNING

Coverplates protect the operator from moving parts. Never operate the pump without coverplates in place. Never apply electric power to the pump without coverplates in place. Always disconnect power before repairing or servicing.

Mechanical Connections

All threaded fuel connections must be sealed with thread tape or a pipe thread sealing compound approved for use with petroleum fuels and tightened securely to prevent leakage.

Your pump must be mounted on a vented tank. If the tank is not vented, contact your GPRO™ distributor for the correct vent cap.

This pump has a built-in check valve to keep the pump primed. No additional check valve is required on suction pipes shorter than 15 feet (4.6 meters). Make sure any check valves or foot valves used are equipped with proper pressure relief valves.

Your pump is designed to mount directly to a standard 2 in. female tank fitting. For the suction pipe, a 1 in. galvanized steel pipe cut to length and threaded on one end may be used. Suction pipe should extend to within 3 inches of tank bottom. Apply thread tape to the suction pipe thread and securely tighten the suction pipe to the tank adapter. Once suction pipe is attached to tank adapter, insert suction pipe into tank and tighten tank adapter to tank fitting.

Install Nozzle Hanger

(Not applicable to pumps with -RD suffix)

Attention: The nozzle hanger for your pump was removed before shipping to protect against damage.

To reinstall the nozzle hanger follow the steps below.

1. Remove the two (2) 1/4"-20 x 1/2" bolts from the switch coverplate.
2. Place the nozzle cover on the switch coverplate and align holes.
3. Insert the two (2) 1/4"-20 x 1/2" bolts through the nozzle cover and thread into the switch coverplate. Torque bolts to 45-60 in/lb (Figure 1).

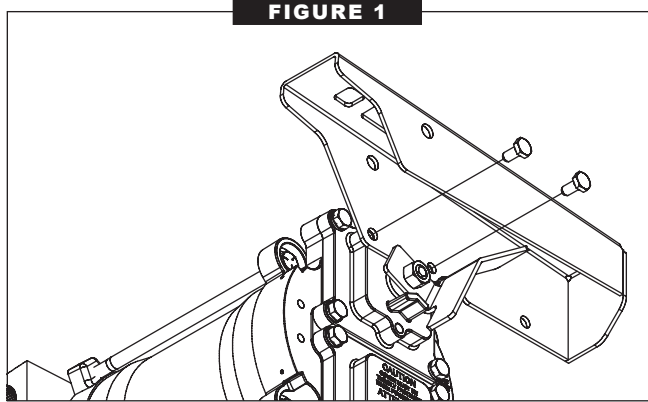

Switch Locking Lever

Attention: The PRO20-115RD remote dispenser pump incorporates an external switch locking lever that locks the pump switch in the "ON" position. The pump is typically shut off using the remote dispensing device "ON-OFF" mechanism.

Electrical Connections

⚠ DANGER

Pump must be installed by a licensed electrician and conform to National Fire Protection Association (NFPA) codes 30 and 70. You, as the owner, are responsible for seeing that the installation and operation of your pump complies with NFPA codes as well as any applicable state and local codes. Rigid conduit must be used to install wiring.

Failure to follow these wiring instructions may result in death or serious injury from shock, fire or explosion.

The pump must be properly grounded to avoid personal injury. Operating an ungrounded or improperly grounded pump may result in death due to electrical shock, fire or explosion.

Electrical wiring and connections must be made only by a licensed electrician in accordance with national, state and local electrical codes regarding Class I, Division 1, Group D locations. Other codes may apply.

Thread for the conduit connection at the pump electrical box is 1/2 in. FNPT.

A standard 15-amp breaker is recommended.

This pump is equipped with an auxiliary AC accessory lead. The third wire (brown for 115-volt system and purple for 230-volt system) is to be used to energize a control circuit that operates a device such as a signal light or a solenoid operated valve. Maximum amp draw on the

control circuit is 1 amp. If you do not need this feature, ensure that the wire is insulated and enclosed within the electrical cavity of the pump.

⚠ CAUTION

Connect pump to the proper voltage source. PRO20-115 Pumps are designed to operate on 115 VAC, 60 Hz.

PRO20-230 Pumps are designed to operate on 220-240 VAC, 50/60 Hz. Connection to improper voltage will damage pump.

Wiring Details

1. Remove electrical coverplate and O-ring (Figure 2). Install conduit and cable from switchbox to pump electrical box. Wiring must be in accordance with Class I, Division 1 requirements in the applicable national electrical code. Note that the lead wires are factory-sealed isolating the motor from the junction box.

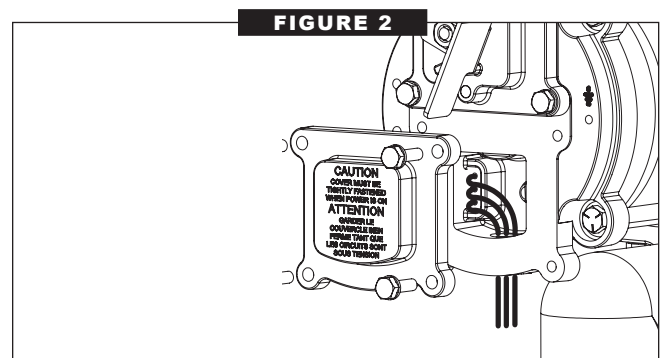

2. Attach ground wire using the green ground screw located inside the electrical box (Figure 3). The external bonding connection is only a supplemental bonding connection where local authorities permit or require such a connection. For 115-volt system connect the power cable to the black and white pump wires and the control circuit (if required) to the brown wire. For 230-volt system connect the power cable to the brown and blue wires and the control circuit (if required) to the purple wire. Secure with wire nuts. Refer to appropriate wiring diagram on Page 4.

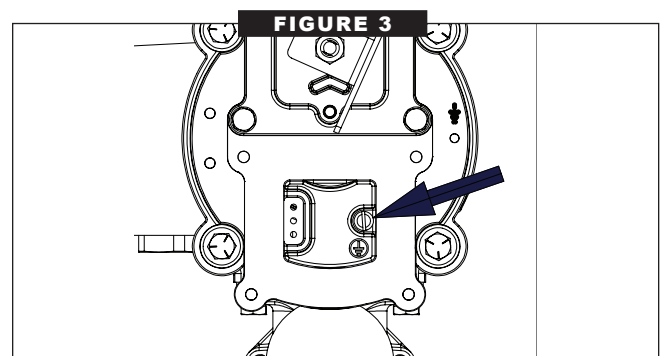

3. Position wires inside the electrical box. Replace O-ring and electrical coverplate. Install all four (4) screws. Torque to 45-60 in. lbs.

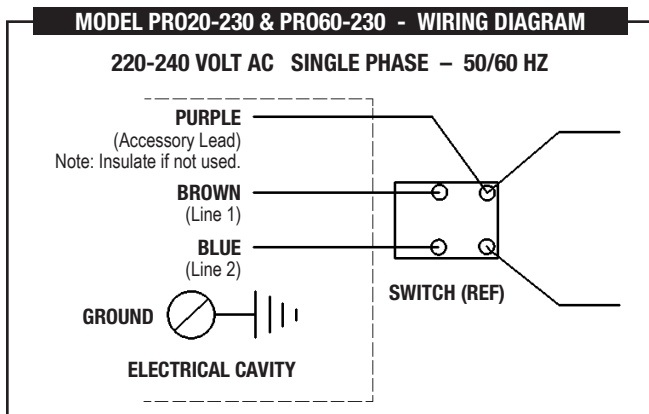
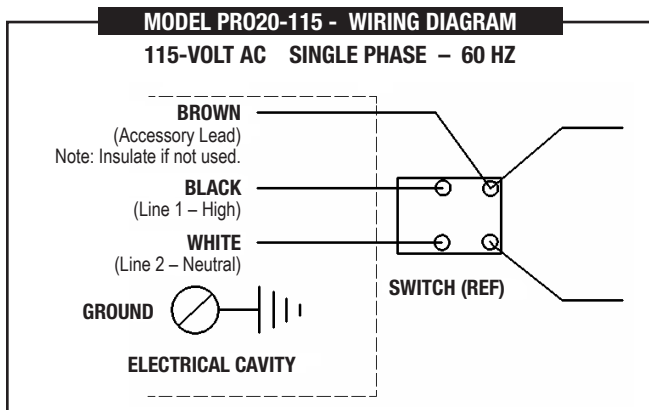

OPERATION

⚠ DANGER

To prevent physical injury, observe precautions against fire or explosion when dispensing fuel. Do not operate the dispenser in the presence of any source of ignition including running or hot engines, lighted cigarettes, or gas or electric heaters.

⚠ WARNING

Observe precautions against electrical shock when operating the system. Serious or fatal shock can result from operating electrical equipment in damp or wet locations.

⚠ CAUTION

Avoid prolonged skin contact with petroleum fuels. Use protective goggles, gloves, and aprons in case of splashing or spills. Change saturated clothing and wash skin promptly with soap and water.

To dispense fuel (for pumps with nozzle hanger):

1. Remove the nozzle from the holder. Turn the pump on by pulling the switch lever down.
2. Insert the nozzle into the receiving tank and squeeze the handle to dispense fuel.
3. After dispensing fuel, push the switch lever up to turn the pump off and return the nozzle to the holder. The nozzle may be locked in place to prevent unauthorized use.

The pump contains an automatic bypass valve to prevent pressure buildup when the pump is on but the nozzle

is closed. Do not leave the pump on for more than 10 minutes with the nozzle closed.

Never leave the pump running without fluid. Dry running can damage the pump components.

The pump has a duty cycle of 30 minutes ON and 30 minutes OFF. Do not overheat. Allow the motor to cool the same length of time it was in operation.

The fuel strainer and check valve assembly should be cleaned on a regular basis or if low flow rate is noticed. If the pump becomes too hot, an internal temperature-limiting device will automatically shut the motor off and prevent operation until it cools.

⚠ CAUTION

Always turn the pump off if the temperature-limiting device trips. The Remote Dispenser pump (PRO20-115RD) turns off at the dispensing device. If left on, the pump will automatically reset when cool and start pumping.

MAINTENANCE

This pump is designed for minimum maintenance. Motor bearings are sealed and require no lubrication. Inspect the pump and components regularly for fuel leaks and make sure the hose and power cord are in good condition. Keep the pump exterior clean to help identify leaks.

Do not use this pump for water, chemicals or herbicides. Dispensing any fluid other than those listed in this manual will damage the pump. Use of the pump with unauthorized fluids will void the warranty.

To Clean or Replace Strainer

All pump models have an inlet strainer. If flowrate is reduced, clean or replace strainer.

Turn the pump off and disconnect from power. Remove and clean the strainer with a soft-bristled brush and solvent. If the strainer is very dirty, compressed air may be used. If damaged, replace the strainer.

Replace components making sure that they are seated and fasteners are tightened securely.

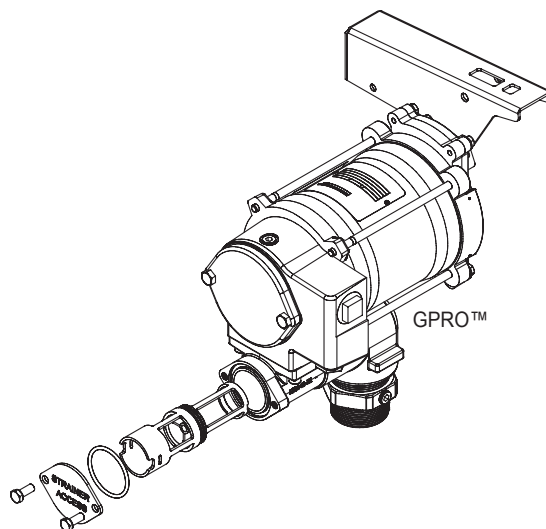

TROUBLESHOOTING

SYMPTOM	PROBABLE CAUSE	CORRECTIVE ACTION
A. MOTOR DOES NOT RUN	1. No electrical power to pump	Check breaker, switchbox and wiring.
	2. Temperature-limiting device tripped	Allow motor to cool. Temperature-limiting device will automatically reset.
	3. Rotor or vanes jammed	Remove coverplate and check for damage or obstruction.
B. MOTOR RUNS, BUT NO FLOW	1. Tank level low	Add fuel to tank.
	2. Clogged filter assembly	Remove and clean filter assembly.
	3. Clogged or broken suction pipe	Remove pump and clear suction pipe, replace as needed.
	4. Broken shaft key	Replace shaft key. Check rotor or vanes for obstruction.
C. PUMP FAILS TO PRIME	1. Air leak in system	Check for air leaks at all joints.
	2. Bypass valve stuck open	Remove bypass valve and clean or replace as needed.
	3. Check valve stuck open	Remove check valve and clean or replace as needed.
	4. Rotor or vanes worn	Check rotor and vanes for excessive wear.
D. LOW FLOWRATE	1. Low voltage	Check incoming line voltage.
	2. Clogged filter assembly	Clean filter assembly.
	3. Air leak in system	Check for air leaks at all joints.
	4. Bypass valve stuck open	Remove bypass valve and clean or replace as needed.
	5. Rotor or vanes worn	Check rotor and vanes for excessive wear.
	6. Outlet is blocked	Check all accessories for blockage.
	7. Clogged or broken suction pipe	Remove pump and clear suction pipe, replace as needed.
E. MOTOR STALLS WHEN NOZZLE IS CLOSED	1. Bypass valve stuck closed	Remove bypass valve and clean or replace as needed.
	2. Rotor or vanes worn	Check rotor and vanes for excessive wear.
	3. Low voltage	Check incoming line voltage.
F. FUEL LEAKAGE	1. Threaded joint loose	Check and reseal threaded joint.
	2. Insufficient bolt torque	Retighten bolts.
	3. Lost or damaged O-rings	Check O-rings for damage. Replace as needed.
	4. Shaft seal worn or damaged	Fuel leaking from drain hole indicates shaft seal needs to be replaced.
G. MOTOR OVERHEATS	1. Pumping high viscosity fluids	Pump only low viscosity fluids.
	2. Clogged filter assembly	Clean filter assembly.
	3. Clogged or broken suction pipe	Remove pump and clear suction pipe, replace as needed.

ILLUSTRATED PARTS DRAWING

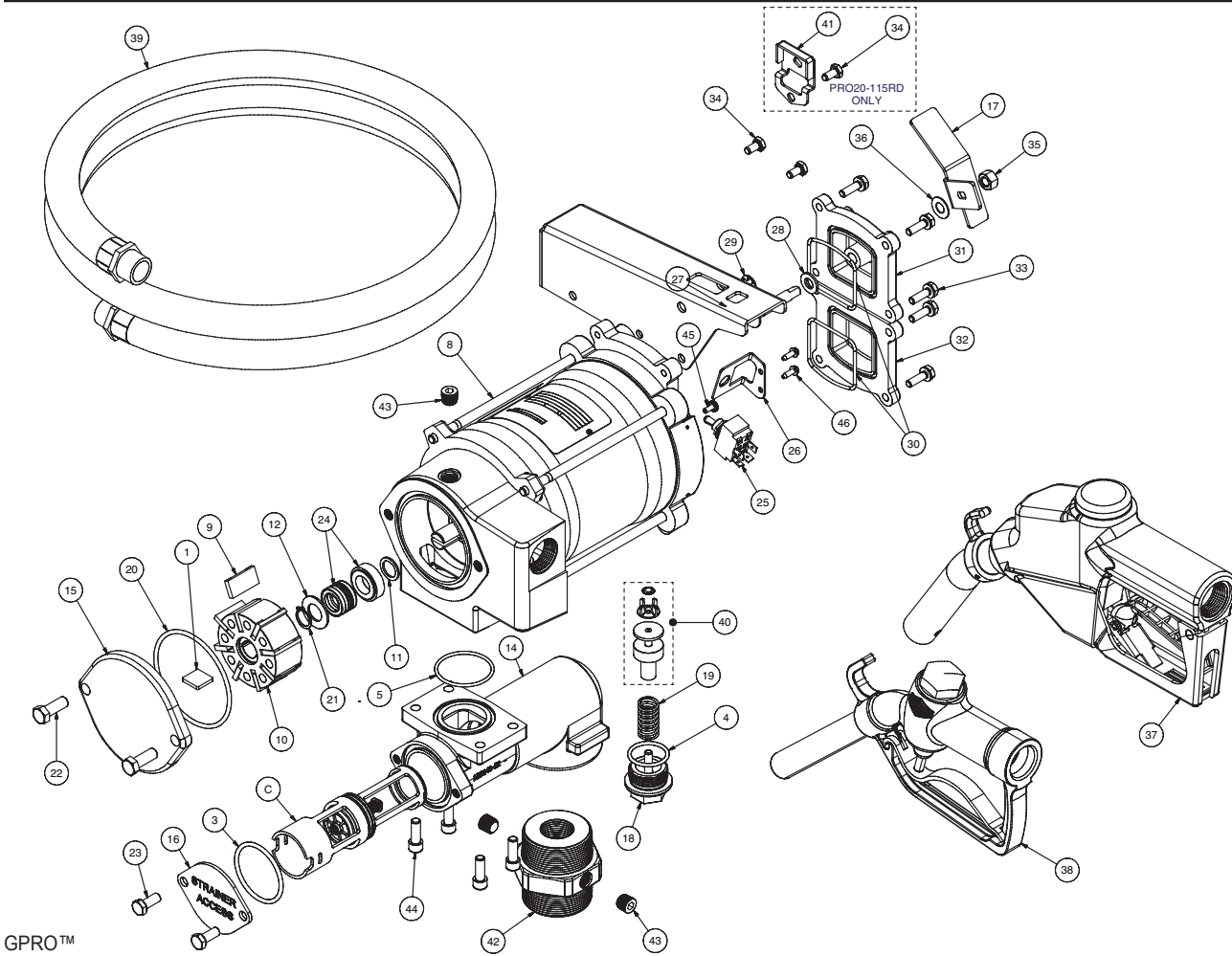

GPRO™

Part No.	Description	No. Req'd.
1	121010-02 Shaft Key.....	1
3	901001-90 O-Ring (or Kit A).....	1
4	901002-50 O-Ring (or Kit A).....	1
5	901002-89 O-Ring (or Kit A).....	1
8	133516-01 1/3 HP Motor Assembly, 115-volt.....	1
	133517-01 1/3 HP Motor Assembly, 230-volt.....	1
9	133020-1 Vanes.....	8
10	133022-1 Rotor.....	1
11	133026-1 Slinger Washer.....	1
12	133027-1 Spacer Washer.....	1
13	13312401 Nozzle Cover.....	1
15	133032-02 Coverplate.....	1
16	133033-1 Base End Plate.....	1
17	13312201 Switch Lever.....	1
18	133059-05 Poppet Plug.....	1
19	133062-1 Poppet Spring.....	1
20	901003-15 O-Ring (or Kit A).....	1
21	904006-33 Retaining Ring.....	1
22	904006-38 Hex Head Screw 3/8 -16 x 1".....	2
23	904001-37 Hex Head Screw 5/16 -18 x 3/4".....	2
24	906006-53 Shaft Seal.....	1
25	133535-01 Switch Kit (Includes Instructions).....	1
26	133848-01 Switch Bracket.....	1
27	133845-01 Switch Actuator Assembly.....	1
28	904006-63 Spring Washer.....	1
29	904004-97 Retaining Ring.....	1
30	110026-6 O-Ring (or Kit A).....	2
31	133802-01 Switch Cover.....	1
32	133881-01 Cover.....	1
33	904005-39 Hex Head Screw 1/4-20 x 7/8".....	8

Part No.	Description	No. Req'd.
34	904003-33 Hex Head Screw 1/4-20 x 1/2".....	2
35	904006-62 Hex Nut, 3/8-16.....	1
36	904006-16 Nylon Washer.....	1
37	906008-570 1" NPT Auto Diesel Nozzle, UL.....	1
	110120-2 Nozzle Hook Only.....	1
	904001-88 Set Screw Only.....	1
38	906001-10 1" NPT Manual Diesel Nozzle.....	1
39	110188-02 Hose Assembly.....	1
40	133505-01 Poppet Assembly Kit.....	1
41	133419-01 Switch Locking Lever (PRO20-115RD only).....	1
42	133142-01 Tank Adapter 2" x 1" NPT.....	1
43	90400812 Pipe Plug, 1/4" NPT.....	2
44	90400823 Socket Head 5/16 -18 x 7/8".....	4
45	904006-70 Ground Screw #10-32 x 3/8".....	4
46	904005-40 Screw, Tapping, #8-32 x 1/2".....	2

Kits and Accessories

133501-1	Vane Kit
133503-1	Shaft Seal Kit
133503-05	Shaft Seal Kit, Extreme Temperature Series
A 133504-1	Seal Kit
B 503500-2	Switch Kit, PRO20-115 / PRO20-230
C 121013-503	Check Valve Assembly Kit
504500-04	Spare Base Assembly 2" inlet
504500-03	Vacuum Breaker Kit
150100-502	Fuel Hose, Extreme Temperature Series, 1" NPT x 1" x 18'
906009-505	Automatic Diesel Nozzle, Extreme Temperature Series, 1" NPT, UL

SPECIFICATIONS

The PRO20-115 and PRO20-230 fuel pumps are designed to safely transfer low viscosity petroleum fuels such as gasoline (up to 15% alcohol blends such as E15), diesel fuel (up to 20% biodiesel blends such as B20) and kerosene. The pumps are designed for permanent mounting on vented storage tanks, either in-ground or above-ground. *RAINPROOF* for outdoor use. Use of alcohol blends above 10% (E10) and biodiesel blends above 5% (B5) have not been reviewed by UL.

Performance

Pump Rate: PRO20-115: Up to 20 GPM (76 LPM)
PRO20-230: Up to 20 GPM (76 LPM) @ 60 Hz
Up to 17 GPM (64 LPM) @ 50 Hz

Duty Cycle: 30 minutes ON, 30 minutes OFF

Dry Prime: 15 ft. (4.6 m) maximum

Discharge Lift: 10 ft. (3 m) maximum

Operating Temperature

-20° F to +125° F (-29° C to +52° C)

XTS Operating Temperature

Extreme Temperature Series pumps are capable of operation down to -40° F. Any pump operation below -20° F has not been evaluated by UL.

Bypass Pressure

22 PSI

Electrical

Input: PRO20-115: 115 VAC, 60 Hz
PRO20-230: 220-240 VAC, 50-60 Hz

Conduit: ½ inch FNPT

Current Draw: PRO20-115: 4.9 amps at full load
PRO20-230: 2.3 amps on 60 Hz
2.5 amps on 50 Hz
at full load on 230 VAC

Motor: PRO20-115: ¼ HP, 1725 RPM
PRO20-230: ¼ HP, 1725 RPM on 60 Hz
or .19 kw, 1425 RPM on 50 Hz

Both motors are induction type with an internal temperature-limiting device.

Mechanical Connections

Bung: 2 inch NPT

Inlet: 1 inch NPT

Outlet: 1 inch NPT

Accessories

Hose: 1 in. NPT x 1 in. x 18 ft. (5.5 m)
Buna-N electrically conductive

Nozzle: 1 in. NPT manual diesel or 1 in. NPT automatic diesel

Security: Nozzle can be padlocked

PARTS AND SERVICE

In order to preserve the UL Listing for pump safety, return the entire pump to the factory for repair or replacement. For products serviced outside the factory, the UL nameplates must be defaced to indicate that the equipment may no longer meet the requirements for UL Listing. This does not apply to products serviced outside the factory under the UL program for Rebuilt Motors for Use in Hazardous Locations.

For warranty consideration, parts, or other service information, please contact your local distributor. If you need further assistance, contact the Great Plains Industries Customer Service Department in Wichita, Kansas, during normal business hours.

800-835-0113 or 316-686-7361

To obtain prompt, efficient service, always be prepared with the following information:

1. The model number of your pump.
2. The manufacturing date code of your pump.

For the PRO20-115 and PRO20-230 series, the date code is located on the motor nameplate.

For warranty work, always be prepared with your original sales slip or other evidence of purchase date.

Please contact Great Plains Industries before returning any pump. It may be possible to diagnose the trouble and find a solution with a telephone call. Great Plains Industries can also inform you of any special requirements you will need to follow for shipping.

⚠ CAUTION

Do not return the pump without authority from the Customer Service Department. Due to strict government regulations, Great Plains Industries cannot accept pumps unless they have been drained and cleaned.

Ship Weight	PRO20-115PO	48.6 lbs (22.0 kg)
	PRO20-115MD	59.5 lbs (27.0 kg)
	PRO20-115AD	61.6 lbs (27.9 kg)
	PRO20-115RD	46.9 lbs (21.3 kg)

SAVE THESE INSTRUCTIONS



Wichita · Sydney · Mexico City

GREAT PLAINS INDUSTRIES



Great Plains Industries, Inc. / 800-835-0113 / GPI.net

© 2019 Great Plains Industries, Inc. All Rights Reserved. Made in U.S.A.  and GPRO™ are trademarks, and the electric gear pump design is a registered trademark of Great Plains Industries, Inc.