

**Andair Ltd
Unit 1,
Dunsbury Business Park,
Fulfood Road,
Havant, Hampshire,
PO9 5AX, England**

**Tel +44(0) 239 247 3945
Fax +44(0) 239 247 3946
Email - info@andair.co.uk
Website - www.andair.co.uk**

Andair
precision aircraft components

PRODUCT - Fuel Boost Pump

The reputation for high quality engineering and superb design continues in the form of the revolutionary New Brushless Motor High Pressure Fuel Pump from Andair.

After extensive research and development Andair have developed the 'PX375-TC' Boost and the 'XP375-TC' Transfer Pump.

Each model features a Brushless motor. This motor, also developed and manufactured by Andair is light weight, powerful and reliable.

The Pump components are D2 tool steel providing unequalled wear characteristics.



Within the body of the PX375-TC Boost Pump is contained the Bypass. This feature allows for fuel to flow around the positive displacement pump, whilst the pump is not running. The porting within the body has been computer optimised to ensure the best possible flow conditions.

The pump also incorporates a pressure relief system. Here, if the pump is pumping against a closed line, the pressure relief port will open and fuel will re-circulate within the pump.

With the Andair Brushless Fuel Pump the motor is immersed within the fuel. This has 3 distinct advantages; the fuel can be used to cool the internals and the design ensures there will never be any leaks between the drive to the pump, furthermore, using advanced materials and machining techniques we can use the fuel to lubricate the internals giving us better performance.

GENERAL PX375-TC SPECIFICATION :-

11-16.6 VDC 6 AMPS MAX / 4.5 AMPS NORM.

16 GPH @ 27-30PSI / OPEN FLOW 55-60 GPH @ 5PSI

NO FLOW MAX PRESS. 30-33 PSI

PRESS. DROP IN BYPASS MODE @ 36 GPH <0.5 PSI

SELF PRIMING TO 10ft (3m) THROUGH 3/8" TUBE

FITTINGS: 1/4 NPT INPUT AND MALE AN-6 OUTPUT

1/4 NPT TO AN-6 ADAPTER INCLUDED.

SOFT START / CONTINUOUS DUTY

WEIGHT 383g / AEROSPACE GRADE ALUMINIUM BODY

The PX375-TC has been developed as a boost fuel pump for the Lycoming I6360 range of engines. If however you require a pump with a different specification please contact Andair. Pump@andair.co.uk

Part No. PX375-TC	CAD generated drawing. Do not manually update.	Issue	ECN#	Change	Date	Drawn	Checked	Approval	Approval Date
		1		First drawn	14/07/2010	A Lindsay			

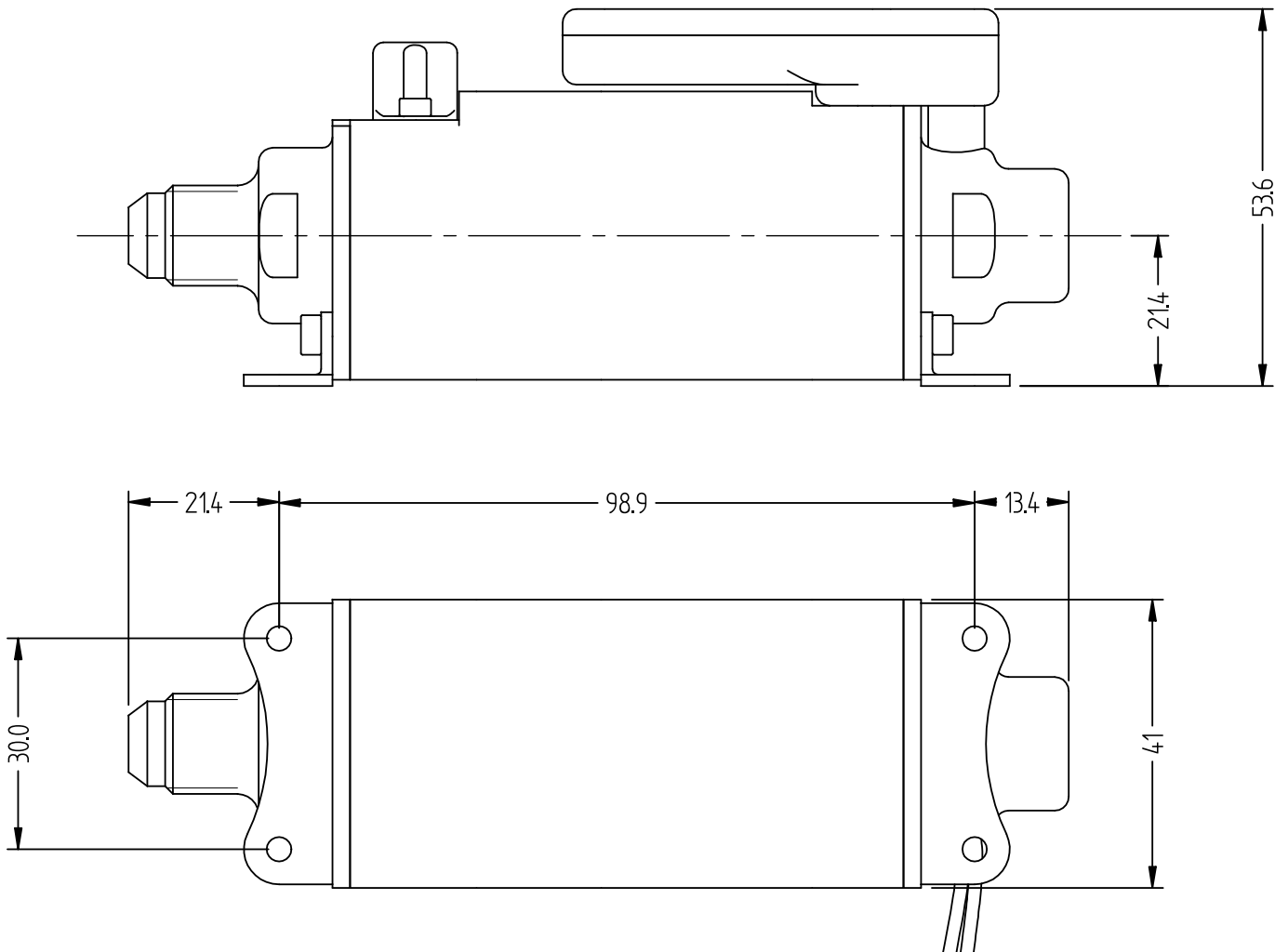

Andair Ltd.	<small>Andair Ltd. OWNS THE COPYRIGHT OF THIS DRAWING WHICH IS SUPPLIED IN CONFIDENCE, AND MUST NOT BE USED FOR ANY PURPOSE OTHER THAN FOR WHICH IT IS SUPPLIED, AND MUST NOT BE REPRODUCED IN WHOLE OR IN PART WITHOUT THE PERMISSION IN WRITING OF THE OWNERS.</small>	All dimensions are in millimeters.		Description: Fuel Pump
	Tolerances unless otherwise specified : x. : ± 0.20 x.x : ± 0.10 x.xx : ± 0.05	Material:		Part No. PX375-TC

Part No.	PCD2	Issue	ECN#	Change	Date	Drawn	Checked	Approval	Approval Date
		1		First drawn	14-07-2010	A Lindsay			

Wiring for PX375-TC, PX500-TC and XP375-TC Pumps

The Pump has two wires, Red and Black, to be connected to the aircraft.

The Red wire should be connected to the Main Bus via a Single Throw Switch and a 6 amp Circuit Breaker.
The Black wire goes to ground (earth).

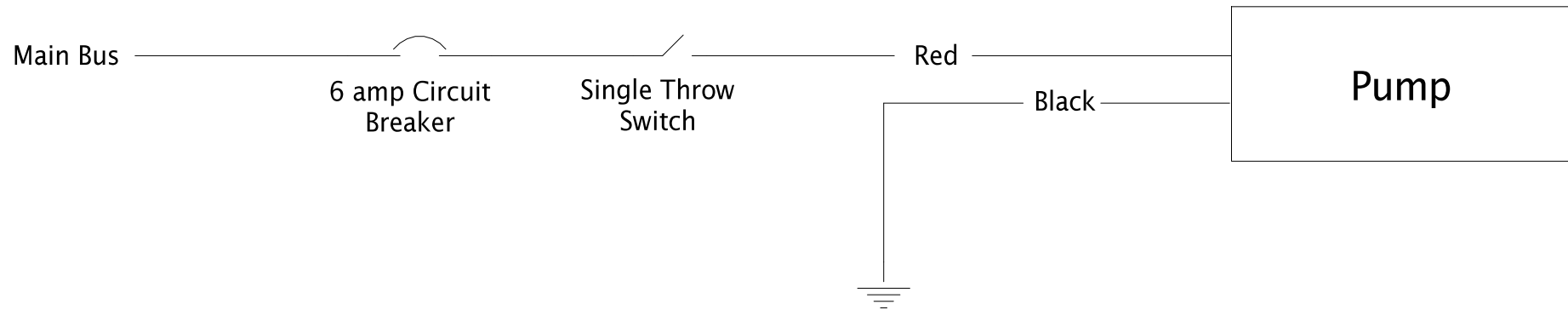

CAD generated drawing.
Do not manually update.

Andair Ltd. OWNS THE COPYRIGHT OF THIS DRAWING WHICH IS SUPPLIED IN CONFIDENCE, AND MUST NOT BE USED FOR ANY PURPOSE OTHER THAN FOR WHICH IT IS SUPPLIED, AND MUST NOT BE REPRODUCED IN WHOLE OR IN PART WITHOUT THE PERMISSION IN WRITING OF THE OWNERS.	All dimensions are in millimeters.			Description: Pump Wiring Diagram
	Tolerances unless otherwise specified : x. : ± 0.20 x.x : ± 0.10 x.xx : ± 0.05	Material:		

Andair