



AIRCRAFT EMERGENCY LOCATOR
TRANSMITTER

OPERATION AND INSTALLATION

INSTRUCTIONS FOR
MODEL 8000 (AF)

FOR HORIZONTAL MOUNTING IN FIXED WING AIRCRAFT OR
ANGULAR MOUNTING IN ROTARY WING AIRCRAFT

TSO-C126
FCC ID: PNT8000xxx

WARNING!
FOR AVIATION EMERGENCY USE ONLY.
UNAUTHORIZED OPERATION PROHIBITED.

CONTENTS

SECTION 1	DESCRIPTION	2
SECTION 2	DIGITAL MESSAGES	4
SECTION 3	PRE-INSTALLATION	4
SECTION 4	INSTALLATION INSTRUCTIONS	5
SECTION 5	FUNCTIONAL TESTING	9
SECTION 6	OPERATING INSTRUCTIONS	11
SECTION 7	BATTERY INFORMATION AND REPLACEMENT	12

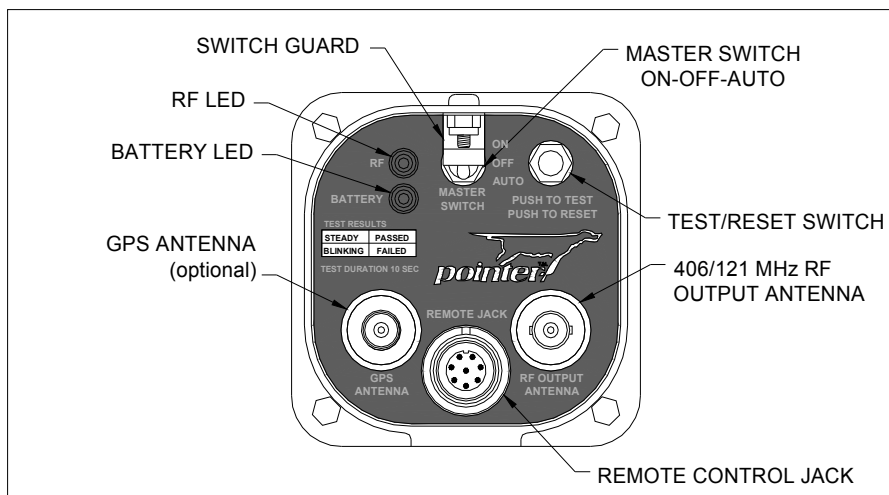

FIGURE 1. POINTER 8000 OPERATING DETAILS

SECTION 1 DESCRIPTION

- 1.1 Pointer 8000 ELT is a self-contained Emergency Locator Transmitter capable of automatic or manual operation (AF).
- 1.2 Pointer 8000 ELT conforms to the new TSO-C126 Digital ELT specification. This requires that each ELT transmits a unique identifying message, greatly reducing the impact of false alarms which troubled previous AM 121.5 MHz ELT technology.
- 1.3 Pointer 8000 ELT is designed to withstand forced landing and crash environment conditions and survive in an operable condition. The highest quality materials and components have been selected for manufacturing to insure rugged, reliable equipment.
- 1.4 Automatic activation is accomplished by a deceleration sensing inertia switch. The inertia switch is designed to activate when the unit senses crash-specific longitudinal inertia forces as described in TSO-C91A.

NOTE: When properly installed, parallel to the line of flight, POINTER 8000 ELT will not activate due to turbulence, normal operation, or aerobatics.

- 1.5 The Pointer 8000 ELT assembly (P/N 8000-X(Y))(see Figure 1) consists of:
 - A A high-impact, high visibility, fire retardant, waterproof case.
 - B A fused battery pack consisting of three Lithium-Manganese Dioxide "D" cells in an impact resistant polystyrene foam housing (P/N 8007-6).
 - C An impact-sensing "G" switch tailored to the requirements of aircraft ELT application.
 - D Two solid-state transmitters, operating at assigned emergency frequencies of 121.5 MHz and 406.037 MHz. The 121.5 MHz transmission is modulated by a distinctive down-

sweeping audio tone. The 406 MHz transmitter features a ± 1 ppm frequency base, enabling precise doppler-shift triangulation from low earth orbit. The transmission is modulated with international NOAA/SARSAT/COSPAS telemetry code identifying the individual ELT and, indirectly, its registered aircraft and owner.

- E RF output coaxial connector.
 - F 2 status indicator LEDs, one for the battery and one for RF output levels.
 - G A Master "ON-OFF-AUTO" toggle switch.
 - H A "TEST" pushbutton switch.
 - I A Remote Control and Status-Indicator connection jack.
 - J Optionally, an internal GPS receiver and additional coaxial connector for its antenna. This option can add position data to the digital message.
- 1.6 The Pointer 8000 ELT accessories (see Figure 2) consist of:
- A Dual-frequency RF antenna (P/N 3001-15).
 - B Antenna interconnection cable (P/N 3002-10).

FIGURE 2. MAJOR SYSTEM COMPONENTS

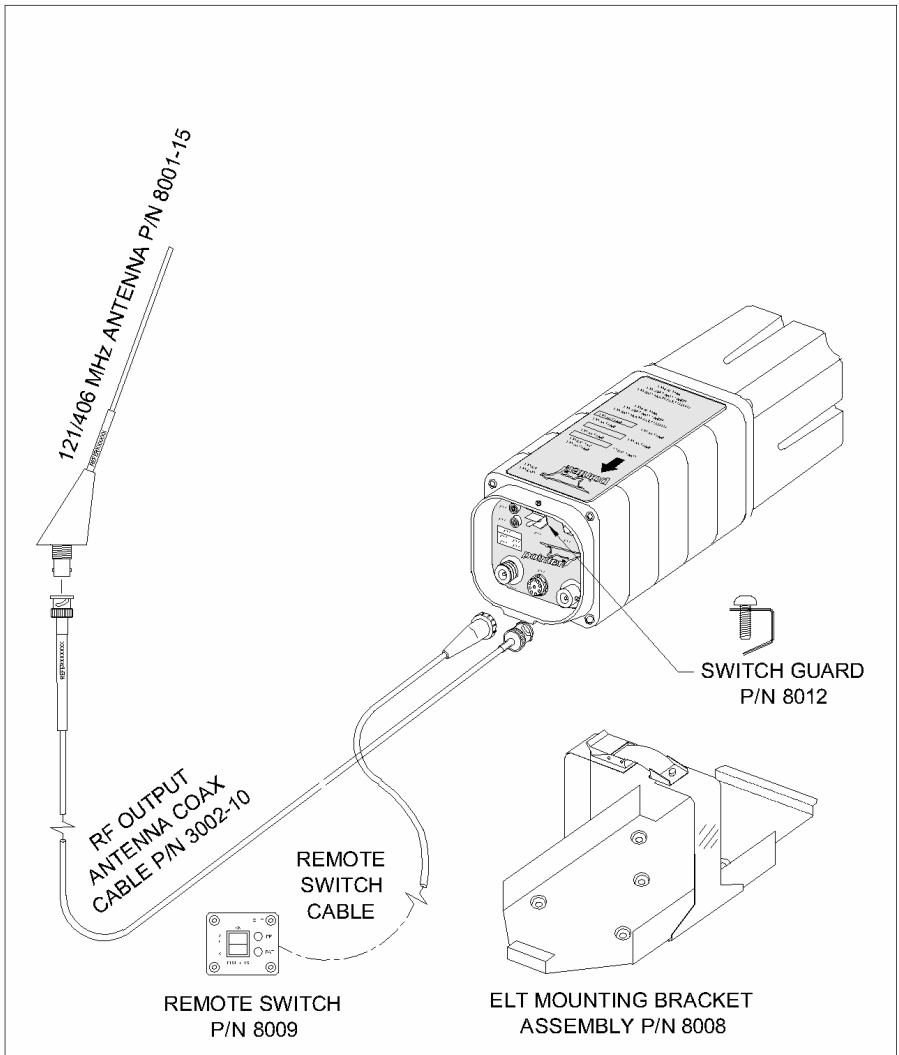

- C A Remote Control / Status Indicator Module and installation kit (P/N 8009).
- D A Master Switch clip and installation kit (P/N 8012).
- E An aluminum mounting bracket with retaining strap (P/N 8008).
- F This operation and installation manual.
- G NOAA (US) and Lifetime Warranty registration postcards.
- H A high-visibility "ELT LOCATED HERE" decal for external airframe application.

SECTION 2 DIGITAL MESSAGES

- 2 ALL 406 MHz DIGITAL BEACONS MUST HAVE THEIR CURRENT OWNER, VESSEL, AND ID REGISTERED WITH THE INTERNATIONAL COSPAS/SARSAT AUTHORITY!** This is normally done through a national body such as (in the US & its territories) NOAA. These national bodies forward their beacon databases to COSPAS/SARSAT. US registration may be accomplished on-line or mail/fax forms obtained at the www.sarsat.noaa.gov website. International registration may be accomplished through the appropriate national point-of-contact as listed on the cospas-sarsat.org website.
- 2.1 ELT Serial Number:** The ELT manufacturer and serial number are encoded at the factory into the digital broadcast message as its unique ID. This is the default configuration of the POINTER 8000 ELT: nothing more need be done other than to register the ELT/aircraft/owner with the appropriate authority.
- 2.2** Other message types may be custom-programmed into the Pointer 8000 ELT, either on special order or by returning its Digital Control Module to the factory or distributor for reprogramming. Contact Pointer for additional information.
- A Registration/Tail Number:** An aircraft's national registration number may be programmed into the Pointer 8000 ELT.
- B 24-bit Aircraft ID:** The international registry assigns a unique binary ID to each aircraft. This is used by navigation and ATC avionics and may also be used by the ELT.
- C Operator-Serial Number:** Fleet operators may have their designated ID and individual aircraft numbers encoded into their ELTs.

SECTION 3 PRE-INSTALLATION

3 GENERAL

Pointer 8000 ELT is designed to be installed in the aft section or cabin of the aircraft. Submission of FAA Field Approval Form 337 is required. The installation and testing should be made in accordance with FAA AC-43.13-2B by qualified personnel. Appropriate weight and balance computations shall be completed and entered in the Aircraft Logbook for each installation.

3.1 PRE-INSTALLATION PREPARATION PROCEDURE

- A Remove the Pointer 8000 ELT from its carton and remove the foam guard from its Master Switch. Verify the Master Switch is in the "OFF" position. (See Fig. 1).
- B If available, connect an appropriate 406 MHz Beacon Tester to the antenna RF output. Otherwise connect a 50 ohm load.
- C Activate and tune an aircraft-band VHF COMM radio to 121.5 MHz.
- D Place Master Switch in the "AUTO" position.
- E Press and release the "TEST" button. The ELT should broadcast analog VHF for five seconds, followed by a ½ second digital burst, and both LEDs should light steadily for an additional 5 seconds. Flashing LEDs indicate a fault. If present, the 406 MHz Beacon Tester should receive a "Self-Test" message containing the unit's digital ID as marked on the ELT side label.
- F Shake the unit firmly parallel to the "DIRECTION OF FLIGHT" arrow on the side label. The down-sweeping analog VHF tone should be heard on the radio. The "BATTERY" and "RF" LEDs should light steadily. Move Master Switch to "OFF" to deactivate.
- G Place the Master Switch in the "ON" position. Down-sweeping VHF audio should be heard immediately. Both LEDs should light steadily.
- H Return the master switch to "OFF" position and remove RF output connection.

POINTER 8000 ELT IS NOW READY FOR INSTALLATION.

NOTICE

IF FOR ANY REASON THE ELT DOES NOT TRANSMIT, OR IF EITHER LED FLASHES DURING ANY OF THE ABOVE TESTS, REPEAT THE PROCEDURE. IF UNIT STILL FAILS TO OPERATE PROPERLY, RE-PACKAGE THE ENTIRE UNIT AS SHIPPED, COMPLETE THE REGISTRATION CARD, PLACE A NOTE OF EXPLANATION AND THE REGISTRATION CARD INSIDE THE BOX AND RETURN THE UNIT TO YOUR DEALER OR THE FACTORY FOR REPLACEMENT.

SECTION 4 INSTALLATION INSTRUCTIONS

4 GENERAL

The following instructions are a general guide for the installation of the POINTER 8000 Aircraft Emergency Locator Transmitter. Installation shall be made in accordance with the requirements of FAA document AC-43.13-2B (Acceptable Methods, Techniques and practices: Aircraft Alterations). Each installation must satisfy airworthiness requirements pertinent to type.

CAUTION!

INSTALLATION IN THE PRESSURIZED AREA OF AN AIRCRAFT CONSTITUTES A MAJOR MODIFICATION. CONSULT LOCAL FAA REGIONAL ENGINEERING OFFICE BEFORE PROCEEDING.

4.1 MOUNTING LOCATION - FIXED-WING AIRCRAFT

- A The POINTER 8000 ELT should be mounted as far aft as possible. Location should be chosen to afford easy and repeated access to the ELT for testing, servicing, and manual deactivation/activation when the aircraft is on the ground.
- B The POINTER 8000 ELT must be solidly mounted. If selecting an area such as between seats, in the luggage area, cabin floor, radio equipment rack, or other flat surface parallel to the longitudinal axis of the aircraft, assure that the mounting surface is solid. DO NOT install in an area subject to flexing or drumming vibrations
- C It is important that the longitudinal axis of the POINTER 8000 ELT is mounted PARALLEL TO the line of flight in fixed-wing aircraft. Mounting the ELT with its axis pointing below the line of flight in the aircraft's landing attitude will result in oversensitivity and increased probability of inadvertent activation in the event of a safe but harder than normal landing.
- D Attach mounting bracket to the aircraft structure so that, when the unit is installed, the "DIRECTION OF FLIGHT" arrow on the ELT points forward in the direction of flight. Drill five holes and attach the mounting bracket with #6 pan head screws. All attaching hardware must be of material and type suitable for Aircraft application. Heads must be flush with bracket surface.
- E Figure 3 shows a typical fixed-wing aircraft installation.

4.2 MOUNTING LOCATION - ROTARY-WING AIRCRAFT (HELICOPTER)

- A The POINTER 8000 ELT must be located on the primary structure. This location must be accessible for manual deactivation/activation, testing, and servicing when the helicopter is on the ground.
- B All other mounting considerations are identical to fixed-wing with the exception of the mounting angle as shown in Figure 4.

4.3 TRANSMITTER INSTALLATION

- A Set the Master Switch to the "AUTO" position and install Master Switch Clip.
- B Insert transmitter into the mounting bracket, attach clip and lock into place.
- C Connect RF antenna and remote control module to their plugs on the ELT.

4.4 WHIP ANTENNA LOCATION AND MOUNTING

Pay particular attention to the following:

- A The POINTER 3001-15 Whip Antenna and 3002-10 coaxial cable are provided to permit external antenna radiation. Use ONLY the cable furnished with the unit. The Whip Antenna should be mounted as far aft as possible on the surface of the aircraft (or helicopter) as this area is normally less susceptible to impact damage.

FIGURE 3. MOUNTING POINTER ELT IN FIXED WING AIRCRAFT

NOTES:

1. TRANSMITTER MAY BE ROTATED LONGITUDINALLY TO MOUNT BUT MUST FACE FORWARD AS SHOWN BY ARROW.
2. MOUNTING SURFACE MUST BE FLAT AND RIGID OVER THE ENTIRE AREA.

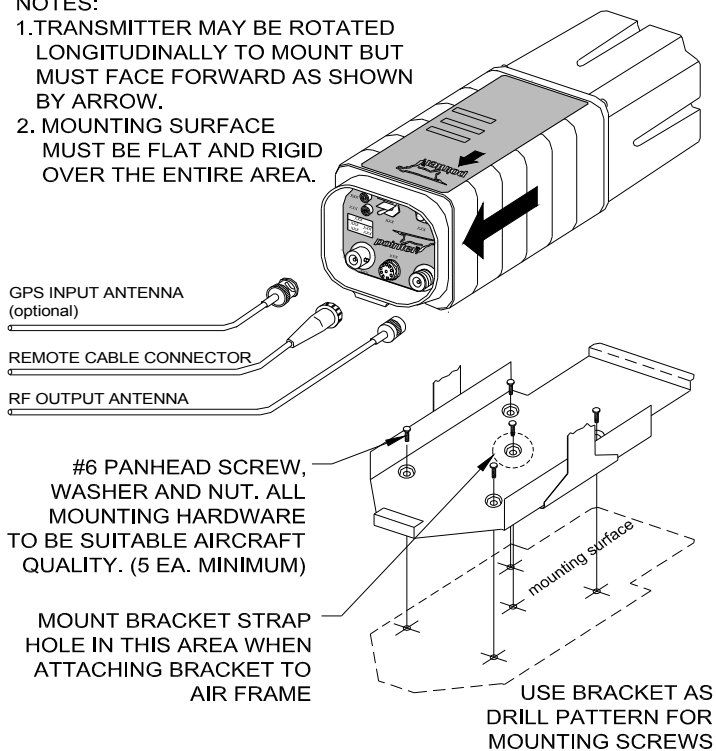

It is important that the unit be mounted PARALLEL TO the longitudinal axis of the aircraft. DO NOT MOUNT THE UNIT AT A DOWNWARD OR NEGATIVE ANGLE.

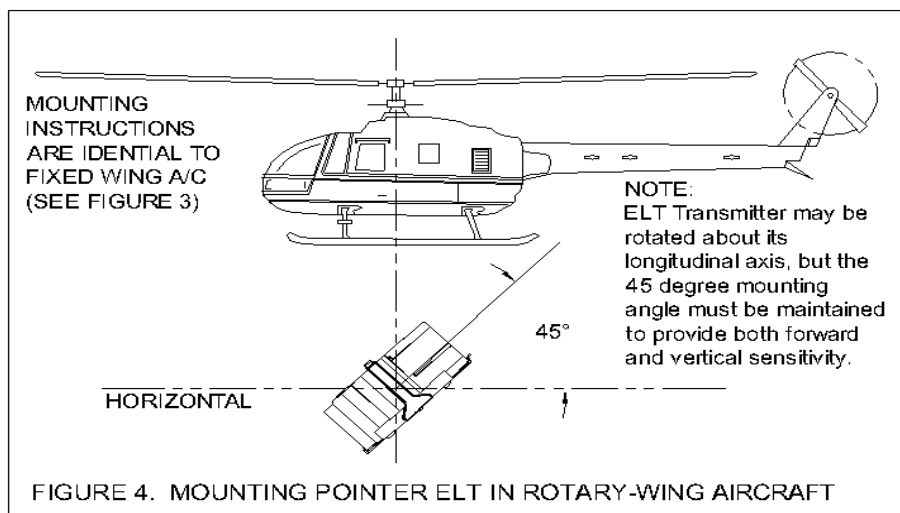
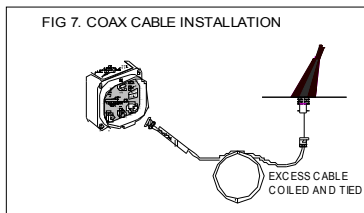
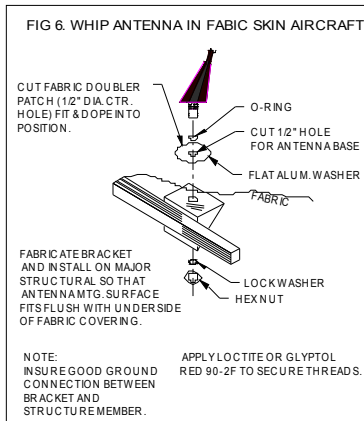
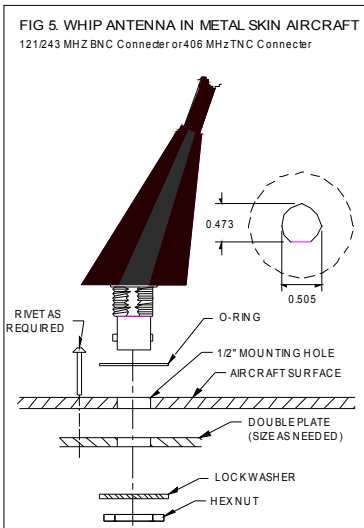

FIGURE 4. MOUNTING POINTER ELT IN ROTARY-WING AIRCRAFT



- B Mount antenna vertically on the upper surface of aircraft (or helicopter).
- C Locate so as to minimize RF coupling from adjacent communications antennas. Maintain maximum practical distance from all other antennas. Mount antenna as close as possible to transmitter. Neatly coil and tie any excess in the 5 ft coax cable (See figure 7). Coaxial cable supplied must not be cut or altered.

4.5 WHIP ANTENNA INSTALLATION

Figures 5 and 6 illustrate details of metal and fabric-skin aircraft antenna installations.

4.6 REMOTE CONTROL/INDICATOR MODULE

The Remote Control/Indicator is required for all installations where the transmitter is not visible to and accessible by the pilot during flight. This unit indicates ELT status and enables the pilot to remotely control the transmitter. This is also useful for ground testing without gaining physical access to the transmitter.

4.1 ITEMS INCLUDED IN THE REMOTE SWITCH KIT (P/N 8009) are listed below:

- A Remote Control/Indicator Module (P/N 8009-01).
- B Label/Faceplate for Remote Control/Indicator Module (P/N 8009-01.9)
- C 6-Pin socket (and loose pins) for connection to Remote Control/Indicator Module.
- D 8-Pin plug (and loose pins) for connection to ELT Unit.
- E Sonalert® piezoelectric audio oscillator/speaker.

4.2 REMOTE MODULE INSTALLATION

- A Choose suitable mounting locations for the Sonalert® speaker and the Remote Control Module. The Sonalert® speaker should be mounted in the aft fuselage near the ELT. A 1½-inch (38mm) square panel area is required for the Remote Control Module.
- B Fabricate and test a wiring harness of suitable length for the aircraft. The cable schematic diagram is shown in Figure 8. MIL-C-27500 (Aircraft Spruce P/N 11-05651 or similar) wire is recommended. 22ga 3-conductor shielded cable from an existing POINTER 3000 (or other ELT) installation may be re-used, if the shield is used for the ground return (Pin #4) signal.
- C Be sure to put the plug pins on the ELT end of the cable and the socket pins on the Remote Control Module end.

- D Cut a 1 1/8" (28.6mm) round hole in the center of the mounting area.
 - E Drill 4 holes for mounting screws (at 45°, 135°, 225° and 315°). The Remote Control Module may be used as a location guide. 100° countersunk Phillips-head screws should be used to properly fit the countersinks in the Remote Module faceplate.
 - F Install interconnecting cable and test.
 - G Install the Remote Module in the panel. Apply the label/faceplate on top of the screw heads for a finished appearance.
- 4.3 **EXTERNAL MARKING:** A bright yellow "ELT LOCATED HERE" decal is supplied to indicate transmitter location.
- 4.4 **RECORD THE INSTALLATION** in Aircraft Logbooks.

FIGURE 8. REMOTE MODULE WIRING DIAGRAM

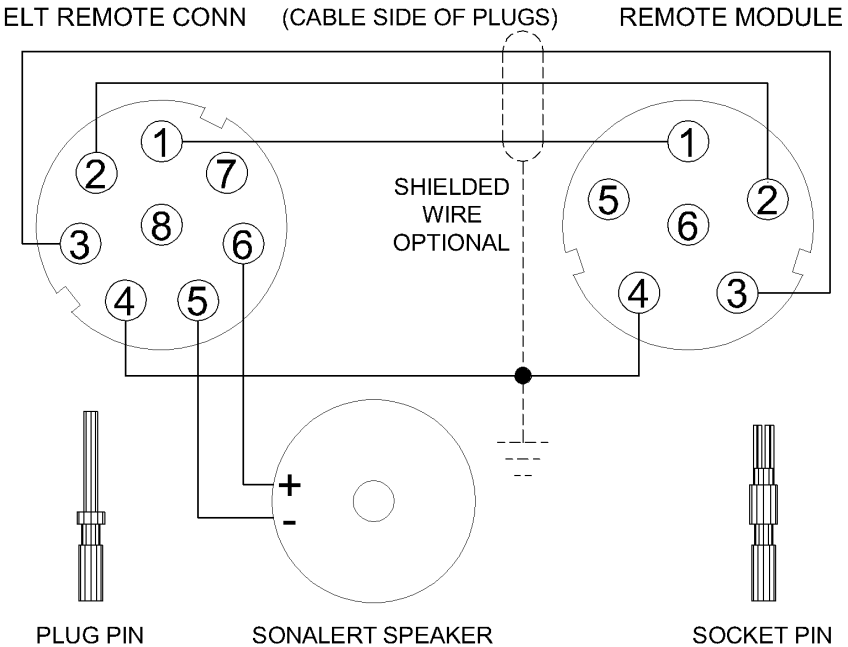

SECTION 5 FUNCTIONAL TESTING

5 GENERAL

- 5.1 The POINTER 8000 ELT system must undergo a functional test for the following reasons.
- A After initial installation.
 - B After system maintenance, such as a battery pack replacement.
 - C Thereafter at owner's or operator's discretion. Annual inspection intervals are required and more frequent inspections are recommended.

5.2 TEST PREPARATION

Visually inspect unit, connections and mounting bracket occasionally for cleanliness and security. Check fixed antenna mounting for tightness. Verify that the ELT Master Switch is in the "AUTO" position and its holding clip is secure.

Test using intervals outlined in FAA advisory circulars.

DON'T over-test. If more than one cumulative hour of testing occurs before the replacement date of the battery pack, the pack should be replaced.

NOTE: Where an aircraft comm. receiver is used:

(A) Tune to 121.5 MHz.

(B) Adjust manual squelch to maximum.

(C) Turn up receiver until slight background noise is heard

(An automatic squelch receiver will not reveal a defective ELT with low RF output power)

Dedicated 406 MHz ELT/EPIRB testers are able to verify most parameters of the 406 MHz digital output during the above test, including RF power, modulation characteristics, and the digital ID code. The ID code must match the "15HEX" ID printed on the ELT's external labeling and registered with the international COSPAS/SARSAT authority.

5.3 POINTER 8000 ELT FUNCTIONAL DETAILS

The unit **Master Switch** functions as follows:

ON: Used to manually activate the POINTER 8000 in emergency situations.

OFF: Used to deactivate and disarm the ELT during handling and after rescue.

AUTO: Used to arm the POINTER 8000 for automatic activation on impact.

FUNCTIONAL TEST OF AIRCRAFT-INSTALLED POINTER ELT

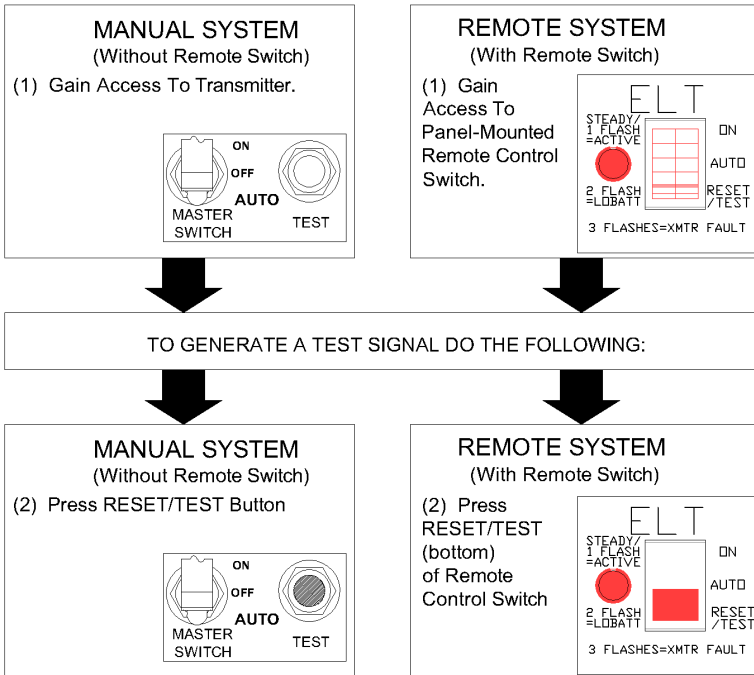

The **Test** button functions as follows (ELT in AUTO mode ONLY):

To test the ELT at the transmitter, press and release the Test switch. The automated test will transmit down-sweeping audio on 121.5 MHz for five seconds, then a single (inaudible) "self-test" burst from the 406 MHz system lasting ~½ second. The down-sweeping audio tone should be audible on a monitoring 121.5 MHz receiver. Both the "RF" and "BATTERY" LED indicators will remain active for 5 seconds after the test. Steady illumination of these indicates a successful test. A flashing "BATTERY" LED indicates a low battery which should be replaced. A flashing "RF" LED indicates an internal fault: return the unit to the factory for repair. Upon test completion, the unit will reset and rearm.

The **Remote Control Switch** functions as follows (ELT in AUTO mode ONLY):

ON: Used to manually activate the beacon in an emergency situation. An example of

such an emergency would be a forced landing with an impact insufficient to activate the "G" switch.

AUTO: Normal armed mode, ready for automatic activation by the "G" switch.

RESET/TEST: Used to test the ELT, and to deactivate and re-arm the transmitter after automatic activation by the "G" switch. An example would be after a hard landing resulting in an inadvertent activation.

The single LED on the Remote Module replaces both local LEDs by lighting steadily for a successful test, flashing single pulses for normal (manual or automatic) activation, flashing double pulses for a low battery, and flashing triple pulses to indicate low RF.

5.4 MAINTENANCE

If the ELT fails to operate properly during testing, remove only the main unit and return it to the manufacturer for inspection and repair. Remove the battery pack (and its housing) before shipping (refer to Section 7) to avoid inadvertent transmission, hazardous material shipment premiums, and to reduce the unit's (weight-based) shipping cost.

SECTION 6 OPERATING INSTRUCTIONS

6 GENERAL

Your POINTER 8000 ELT has been engineered to provide the most reliable operation possible. Every contingency has been considered in the design and construction of the POINTER 8000 ELT system. The following section will acquaint you with the simple operational procedures of the POINTER 8000 ELT. It is recommended that you familiarize yourself thoroughly with these procedures and have them firmly in mind to add to your flying confidence.

6.1 It is recommended that the following steps be taken to insure the best possible operation in an emergency.

- A Become thoroughly familiar with the POINTER ELT instructions.
- B Keep them on hand in the aircraft at all times.
- C Visually inspect the unit at regular intervals for cleanliness and security. Check external antenna mounting and cable connections for tightness.

6.2 OPERATING MODE POINTER ELT INSTALLED IN AIRCRAFT

- A After a forced landing, if the aircraft's COM receiver is operable, listen on 121.5 MHz for audio transmissions. Ensure that external antenna is clear of obstructions.
- B The range of the POINTER 8000 ELT varies according to signal type, weather, and topography. The 406 MHz digital signal is intended to be received by satellites in both low (LEOS) and geosynchronous (GEOS) orbits. Depending on terrain, the 121.5 MHz swept audio homing signal may be heard up to 30 miles by a search aircraft at 10,000 ft. Stay close to the downed aircraft to permit easier spotting by airborne searchers.

The following table gives the switch positions and functions for various situations.

MANUAL ACTIVATION: Via Local Switches on POINTER 8000 ELT		
MODE	Switch Position	FUNCTION
AUTO/ ARM	" AUTO " (Normal Flight Setting)	ELT "armed" and automatically activated if "G" switch senses predetermined deceleration level.
MANUAL ON	" ON "	Overrides "G" Switch and activates ELT manually if pilot wishes to activate ELT prior to imminent emergency situation.
OFF/ DISARM	" OFF "	Deactivates POINTER ELT in preparation for removal from aircraft or to discontinue signal after rescue.
TEST	Press and release " TEST " pushbutton	11-second single-burst "self- test" may be performed on the ground or in flight.

REMOTE ACTIVATION: Via Remote Module on Instrument Panel		
Master Switch on Transmitter	Remote Switch on Control Panel	FUNCTION
"AUTO"	"AUTO" (Normal Flight Setting)	ELT automatically activated if "G" switch senses predetermined deceleration level.
"AUTO"	"ON"	Overrides "G" Switch and turns ELT on so it can be tested for proper operation on the ground ---- OR ---- If emergency situation is imminent and pilot wishes to activate ELT prior to emergency
"AUTO"	Press and release "RESET/TEST" (momentary)	If inadvertent activation occurs in system, the transmitter can be restored to "ARMED" status by momentarily pressing "RESET/TEST."
"AUTO"	Press and release "RESET/TEST"	Single-burst operational test may be performed on the ground or in flight.

SECTION 7 BATTERY INFORMATION AND REPLACEMENT

7 GENERAL

Power is derived from a safety-fused, impact-resistant molded polystyrene foam battery pack containing three 3V Lithium-Manganese Dioxide "D" size batteries in series. Fresh battery open-circuit voltage is 9 volts. Nominal output under load is 7.5 volts.

7.1 WHEN TO REPLACE BATTERY PACK

In accordance with FAA regulations, batteries must be replaced at the following times:

- A After **five** years from its imprinted date of manufacture. This replacement date is imprinted on the battery pack and also on an external label.
- B After the transmitter has been used in an emergency situation (including any inadvertent activation of unknown duration).
- C After the transmitter has been operated for more than one cumulative hour (e.g. time accumulated in several tests and an inadvertent activation of known duration).

Check with your local dealer or distributor for approved replacement battery packs.

**WARNING: DO NOT ATTEMPT TO RECHARGE THE BATTERY PACK!
PACK IS FUSE-PROTECTED. DO NOT SHORT-CIRCUIT!**

7.2 REMOVING THE TRANSMITTER FROM AIRCRAFT

Transmitter must be removed from the aircraft for battery replacement:

- A Remove the Switch Guard and place the Master Switch in the "OFF" position.
- B Disconnect the antenna cable and the Remote Module connector.
- C Open latch on the hold-down strap and remove the transmitter from the mounting bracket.

7.3 REPLACE BATTERY PACK AS FOLLOWS (See Figure 13):

- A Remove (and retain) four screws from back of ELT.
- B Slide battery housing back (save gasket), and disconnect the transmitter connector (6 leads) by carefully depressing the release latch on the connector.
- C Disconnect the battery connector (2 leads) from the G-Switch P.C.B. by carefully depressing the release latch on the connector.
- D Remove (and retain) the five screws attaching G-Switch board to the housing.
- E Remove and replace the battery pack.
- F Reverse steps A-D to reassemble the POINTER 8000 ELT.
- G Exercise care not to over tighten the circuit board screws during reassembly.
- H Exercise care to insure that the O-ring gasket is completely contained within its channel.
- I Seal External cover screw holes with RTV silicon sealer.

7.4 Apply new battery replacement date label, supplied with replacement pack, on battery case back prior to re-installing transmitter in aircraft.

7.5 Reverse step 7.2 to reinstall transmitter in aircraft.

7.6 Test in accordance with Section 3.1 and Section 5.2: Function testing.

FIGURE 13: BATTERY REPLACEMENT

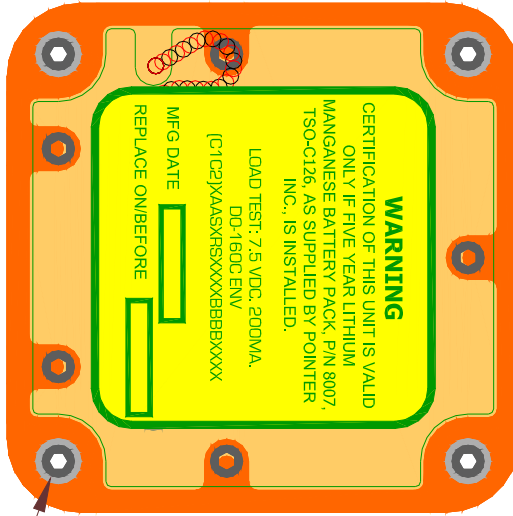

4 Screws attach
Battery Section to
Remainder of ELT

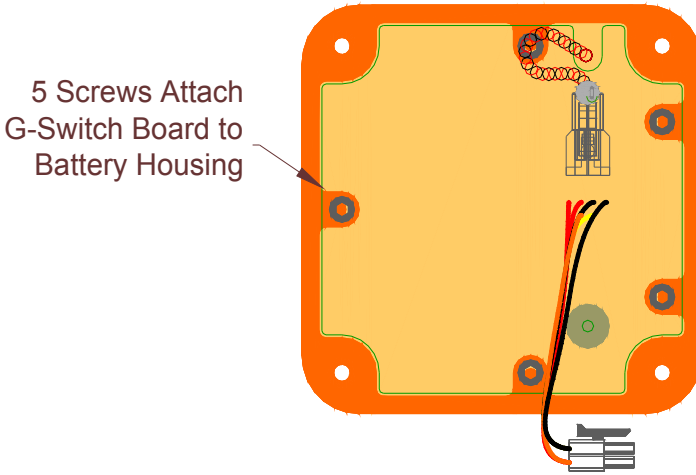

5 Screws Attach
G-Switch Board to
Battery Housing

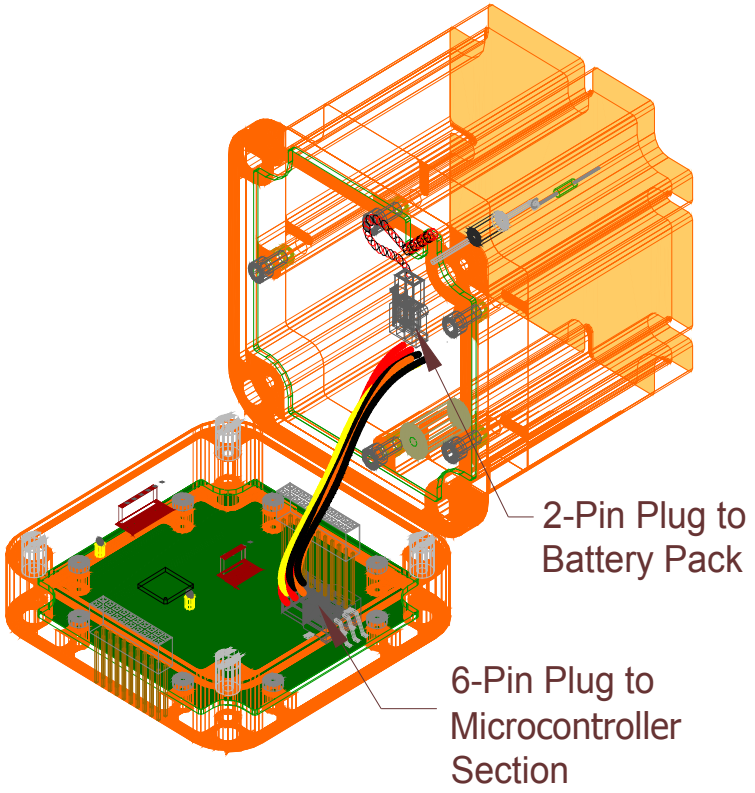

SECTION 8 OPTIONAL GNSS RECEIVER

8 GENERAL

The POINTER 8000 ELT may be equipped with an optional GNSS receiver subsystem which produces geographic position data for inclusion in its digital message output. This variation is ordered and referred to as a POINTER 8000(G) ELT.

8.1 DIGITAL MESSAGES All 406 MHz digital beacons broadcast signals with extremely tight carrier frequency accuracy (1ppm long-term and 2ppb short-term) which enable LEOS receivers to triangulate the transmitter's position using doppler-ranging techniques. The GNSS receiver supplies position data which is included in the digital message, received by both LEOS and GEOS systems, and relayed to COSPAS/SARSAT ground facilities. This is the only way in which a GEO satellite can report a beacon's location.

8.2 ADDITIONAL ANTENNA REQUIRED The US GPS system operates on a frequency of 1.5 GHz, requiring a second, active antenna to be mounted on the aircraft exterior, with appropriate coaxial cable and a second RF connector at the ELT. These are included in the accessories of the POINTER 8000(G) ELT. The mounting of the GNSS antenna requires the same considerations as the RF output antenna, as detailed in Section 4.

8.3 SPECIAL GNSS SELF-TEST Since the GNSS receiver requires several minutes to obtain position data from the GPS satellites, the normal 11-second self-test described in Section 5 cannot properly test it, and does not activate the GNSS receiver. A separate self-test is required to verify proper operation of the GNSS. This test also requires a 406 MHz COSPAS/SARSAT Beacon Tester to receive and present the contents of the digital ELT message - an aircraft-band AM receiver will not suffice.

8.4 BATTERY CONSIDERATIONS The GNSS self-test mode does not activate either of the two RF oscillators or transmitters of the POINTER 8000(G) ELT, therefore its operation depletes the battery much more slowly than normal activation. GNSS self-test time counts as only $\frac{1}{4}$ as long as normal activation time. While it will usually be much less, it can take up to twenty minutes for the GNSS receiver to obtain sufficient data from the orbiting satellites to calculate a position fix. We therefore do not recommend testing the GNSS system more frequently than annually. The best time to test the GNSS is immediately before replacing the battery, so that the test will not count in the battery's operational lifetime. Five GNSS tests (one at installation and four more at annual intervals over the battery's lifetime) add up to a maximum of one hundred minutes of GNSS test operation, counting as twenty-five minutes of normal activation, which is well within the one hour operational time permitted. A sixth test before battery replacement would reduce the test load on the new battery to four tests over its five-year life, with a fifth test immediately before replacement.

8.5 TEST PROCEDURE Test the GNSS receiver as follows:

- A Gain physical access to the ELT. Disconnect the RF output antenna and connect a 406 MHz TSO-C126 Digital Beacon Tester to the RF output of the ELT.
- B Disable any automatic sleep/shutdown feature of the Beacon Tester to force it to stay active for at least twenty minutes. Set the Beacon Tester to capture and record the digital message bursts from the ELT.
- C Press (and release) the TEST/RESET button on the ELT (or the TEST/RESET switch on the remote control/indicator module) at least five times in quick succession. The first press will activate the normal self-test mode. Press the button repeatedly until the LED indicators begin alternately flashing at $\frac{1}{2}$ second intervals.
- D WAIT. The test may take up to twenty minutes, but will probably be much shorter. When complete, the ELT will sound the Sonalert®, deactivate, and automatically rearm itself. RECORD THE TIME ELAPSED during the GNSS test for battery lifetime accounting (if the battery is not being replaced).

E TEST RESULTS

SUCCESS is indicated by a 406 MHz digital message being emitted by the ELT and received by the Beacon Tester. It should present the digital ID of the unit, the geographic position reported by the GNSS, and other characteristics of the digital

message. The reported position may be verified against a position obtained from, for example, the aircraft's navigation avionics.

GNSS FAILURE is indicated by ELT shutdown (and automatic rearming) without any 406 MHz digital broadcast. The ELT may still be used, but should be returned to Pointer for repair of the GNSS subsystem as soon as practical.

- F SYSTEM RESTORATION: Disconnect the Beacon Tester and reconnect the RF output antenna. Or remove the ELT for battery replacement per Section 7.

1.1 WARRANTY

POINTER, INC warrants each new Pointer Emergency Locator Transmitter to be free of defects in material and workmanship, to the original purchaser, indefinitely, provided the unit is equipped with a POINTER, Inc. manufactured battery pack. The company will repair or replace, free of charge, at its factory, any part or parts found to be defective under normal use and service – PROVIDED that the enclosed warranty card is properly completed and mailed within 15 days after installation and is on file with POINTER. This warranty does not cover shipping cost or removal and re-installation of the unit in the aircraft.

This warranty does not cover defects resulting from alterations, improper use or installation, tampering or failure of the purchaser to follow normal operating procedures outlined in the user's instructions, nor for example, does it cover damage resulting from acts of God, such as floods, tornadoes, or lightning.

This warranty is made only to original purchasers in the United States and does not cover the responsibility for the shipping expenses in returning the transmitter or accessory to POINTER or return to the purchaser.

THE WARRANTY PROVISIONS SET FORTH ABOVE ARE IN LIEU OF ANY AND ALL OTHER WARRANTY. WHETHER EXPRESSED OR IMPLIED, INCLUDING THE WARRANTIES OF MERCHANTABILITY OR FITNESS FOR A PARTICULAR PURPOSE, AND ANY OTHER OBLIGATIONS OR LIABILITY WHATSOEVER ON THE PART OF POINTER, INC. OR ANY OF ITS FRANCHISED DEALERS.

NOTICE

The preceding instructions are a general guide for the installation of Pointer Automatic Emergency Locator Transmitters. Installation should be made in accordance with FAA installation requirements by an approved installation facility.



MFG. BY POINTER, INC.
1027 NORTH STADEM DRIVE
TEMPE, ARIZONA 85281

