



Click the icon for a tutorial on how to use the interactive portion of this manual.

AVIDYNE™

IFD5XX / IFD4XX / Atlas Integrated Flight Display

Installation Manual

for Fixed Wing Applications

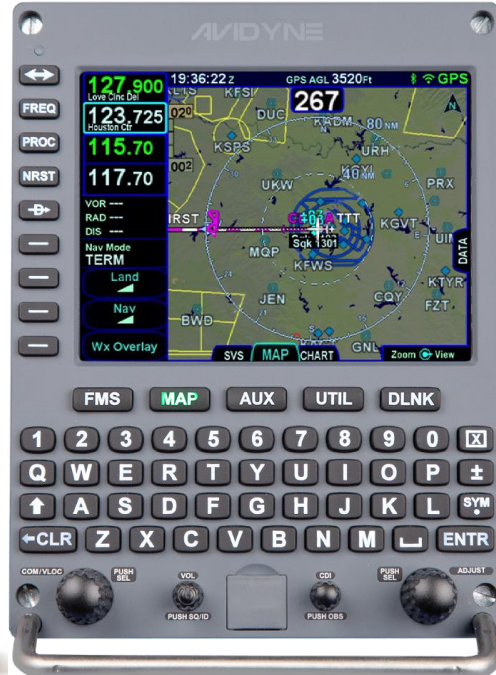

Revision History

Document Number		600-00299-000	Control Category	CC2
Revision	Description	ECO	Date	
00	Initial Release	ECO-14-207	07/09/14	
01	Release 10.0.1.0	ECO-14-283	08/21/14	
02	Release 10.0.2.0	ECO-14-356	11/12/14	
03	Release 10.0.3.0	ECO-14-424	02/02/15	
04	Release for TSO	ECO-15-154	04/09/15	
05	Define MLB100 TSO part number	ECO-15-385	09/29/15	
06	Support WiFi Bluetooth activation utility	ECO-15-425	11/06/15	
07	Release 10.1.1.0	ECO-15-469	12/04/15	
08	Release 10.1.2.0	ECO-16-054	03/01/16	
09	Add EASA Verbiage and 10.1.3	ECO-16-054	06/23/16	
10	Release 10.2	ECO-17-001	02/03/17	
11	Minor error correction to D-44, D-45, Table 73	ECO-17-060	03/08/17	
12	Minor error correction to D-44, D-45, Table 73	ECO-17-066	03/15/17	
13	Release 10.2.1.0	ECO-18-013	02/09/18	
14	Release 10.2.1.0 minor corrections	ECO-18-066	03/07/18	
15	Add Proline 21 EFIS /APS 3000 AP	ECO-18-138	05/16/18	
16	Update for GPS roll-over of the 10 bit number of weeks, Update Table 1 and 2	ECO-19-025	02/08/19	
17	Release 10.2.3.1	ECO-19-050	04/29/19	
18	Added ARINC429 output tables, Proline 21 schematics and configuration settings.	ECO-19-190	08/16/19	
19	Release 10.2.4.1	ECO-19-289	01/16/20	
20	Updated with part 25 aircraft, updated options P/N's, added to the Mods table, Added Honeywell EGPWS, added RDR2100, RDS Radars, fixed DME42 strapping, added Honeywell EPGWS interconnects, added password configuration instructions added GTX3000, NGT700, MST70B BXT65XX interconnects	ECO-20-093	08/24/20	
21	Release 10.2.5.1, Becker remote	ECO-20-162	02/05/21	
22	Release 10.2.6.1	ECO-21-049	03/09/21	
23	Adding Atlas, update IRU Cal	ECO-21-062	04/02/21	
24	Release 10.3	ECO-21-236	05/17/22	
25	Release 10.3.1.2, add Atlas FMS Only	ECO-22-268	02/10/23	

All materials copyrighted, including images that represent the software.

Copyright 2014-2021 Avidyne Corporation. All rights reserved.

The latest installation manuals are available to authorized dealers on the web at <https://www.dealers.avidyne.com>

Avidyne® is a registered trademark of Avidyne Corporation.

Table of Contents

1. General Information	14
1.1 Introduction	14
1.2 IFD Configurations.....	14
1.3 Bendix King Part Numbers	18
1.4 Unit Modifications	20
1.5 Technical Specifications	26
1.5.1 IFD5XX Specifications	26
1.5.2 Atlas Specifications.....	33
1.6 Regulatory Compliance	37
1.6.1 Applicable TSOs	37
1.6.2 TSO Deviations.....	38
1.6.3 Non-TSO Functions	40
1.6.4 Partial TSO Functions.....	40
1.6.5 Open Problem Report.....	41
1.7 Software and Hardware Design Assurance Levels	41
1.8 Environmental Qualification Forms.....	42
1.9 Databases.....	42
1.10 Electronic Map Display Information	42
1.11 GPS Fault Detection and Exclusion (FDE).....	43
1.12 Terrain Alerting and Warning System.....	43
1.13 FIS-B ADS-B Weather Information.....	44
1.14 Part 23 STC Approved Model List	44
1.15 Part 25 STC Approved Model List	44
1.16 Avidyne Supplied Material	45
1.16.1 Product Ship Kits	45

1.16.2	Optional Ship Kits	46
1.17	Materials Required but not Supplied	47
2.	Installation Considerations.....	48
2.1.1	VFR Installation	48
2.1.2	IFR Installation.....	48
2.2	Garmin GNS Replacement Considerations.....	51
2.2.1	Circuit Breakers	51
2.2.2	WAAS Enabled:.....	51
2.2.3	TAWS:.....	52
2.2.4	TAWS Audio:	52
2.2.5	Installation with Avidyne AXP340/322 Transponder:	52
2.2.6	Additional Installation Data Sources	52
2.2.7	Electrical Load Analysis (ELA).....	53
2.3	Optional Installation Features	54
2.4	IFD Interfaces	55
2.5	Pre-Installation Checklist	62
3.	Antenna Installation	63
3.1	Antenna Bonding	63
3.2	Antenna Environmental Qualifications.....	63
3.3	GPS Antenna	63
3.3.1	GPS Antenna Location	64
3.3.2	GPS Antenna Bonding.....	68
3.3.3	GPS Antenna Cable	68
3.3.4	GPS Coaxial Cable Connector	68
3.3.5	Approved GPS Antennas.....	69
3.3.6	GPS Interference	69
3.3.7	Ground Plane.....	70

3.3.8	Dual IFD Installations.....	70
3.3.9	Anti-Ice Protection	70
3.4	VHF Communication Antenna	71
3.4.1	Antenna Environmental Qualifications.....	71
3.4.2	VHF Communication Cable	71
3.4.3	VHF Coaxial Cable Connector	71
3.4.4	Voltage Standing Wave Ratio.....	71
3.4.5	VHF Antenna	71
3.4.6	Antenna Ground Plane	71
3.5	Navigation Antennas.....	71
3.5.1	VOR/LOC Antenna	71
3.5.2	Navigation Coaxial Cable	71
3.5.3	Navigation Coaxial Cable Connector.....	72
3.5.4	Diplexer.....	72
3.6	Glideslope Antenna	72
3.6.1	Glideslope.....	72
4.	Electrical Installation.....	73
4.1	Wire Type	73
4.2	Wire and Connector Identification	73
4.3	Wire Routing.....	73
4.4	Shield Grounds.....	73
4.5	Wire Harness Overbraid	73
4.5.1	Existing Equipment	73
4.5.2	Severe Lightning Transient Environment	73
4.5.3	Copper Overbraid Installation.....	74
4.6	IFD Connectors.....	74
4.7	Byteflight Digital Data Bus Consideration – Dual IFD Installations	75

4.7.1	Databus Wiring - Replacement Installations.....	75
4.7.2	Databus Wiring – New Installations.....	75
4.8	Circuit Protection	75
4.9	Power Distribution.....	75
4.10	Electrical Load Analysis.....	77
4.11	Low Power Behaviors	77
5.	Mechanical Installation	78
5.1	Equipment Location – New Installations.....	78
5.1.1	Determining the IFD Field of View.....	78
5.1.2	Navigation and TAWS (if enabled) Annunciation	79
5.1.3	Course Deviation Indicator	81
5.1.4	Instrument Panel Cutout.....	81
5.1.5	Requirements for Tray Installation.....	81
5.2	Equipment Location - Replacement Unit.....	82
5.3	Equipment Location - Atlas Unit	82
5.4	Angle of Regard.....	82
5.5	Unit Installation/Removal.....	83
5.5.1	IFD IFD5XX/4XX Installation/Removal.....	83
5.5.2	Atlas Installation/Removal	83
5.6	Internal Cooling.....	83
5.7	External Cooling	84
5.8	Electrical Bonding.....	84
5.9	Aircraft Considerations	84
5.10	Weight and Balance.....	84
5.11	Compass Safe Distance	84
6.	System Installation.....	86
6.1	Pin Function List	86

6.1.1	P1001 Main Connector.....	86
6.1.2	P1002 Communication Connector.....	89
6.1.3	P1006 Navigation Connector.....	90
6.1.4	P1050 Additional I/O Connector.....	91
6.1.5	Altitude Gray Code.....	92
6.1.6	Heading Input.....	92
6.1.7	Main Course Deviation Indicator Output.....	93
6.1.8	Serial Data.....	97
6.1.9	ARINC 429.....	97
6.1.10	ARINC 453.....	101
6.1.11	RS170 Video.....	101
6.1.12	Com/VOR/ILS Audio Electrical Characteristics.....	101
6.1.13	VOR/ILS Indicator Electrical Characteristics.....	103
6.1.14	DME Tuning.....	103
6.2	Bezel Lighting.....	104
6.3	Traffic System.....	105
6.4	Lightning Detection System.....	105
6.5	Datalink Weather.....	105
6.6	Audio Panels.....	106
6.7	GAD 42.....	107
6.8	Air Data System Sources.....	108
6.9	Heading System Sources.....	110
6.10	Multifunction Displays.....	111
6.11	Forward Looking Terrain Alerting.....	111
6.11.1	Audio.....	111
6.11.2	Annunciators.....	111
6.12	Fixed Wing TAWS Unlock.....	112
6.12.1	Fixed Wing TAWS Audio.....	112

6.12.2	Fixed Wing TAWS Annunciators	112
6.13	External TAWS/EGPWS Output.....	113
6.14	ADS-B Transponder/UAT Output	113
6.15	Autopilot.....	120
6.16	Video Input.....	120
6.17	Radar Display and Control.....	121
7.	Configuration and Checkout	122
7.1	Wiring Check	122
7.2	Mounting Check.....	122
7.3	Chassis ID Setting	122
7.4	Unit Installation	123
7.5	Configuration	123
7.5.1	Maintenance Mode	123
7.5.2	Password PIN Page.....	124
7.5.3	ARINC 429 Port Configuration	126
7.5.4	RS-232 Port Configuration.....	132
7.5.5	Main System Configuration	137
7.5.6	Main Input Configuration.....	142
7.5.7	Main Lighting Configuration	143
7.5.8	Main Discrete I/O	147
7.5.9	Main CDI/OBS Config Page	149
7.5.10	VOR/LOC/GS CDI	152
7.5.11	VOR/LOC/GS ARINC 429 Configuration.....	154
7.5.12	Com Setup.....	155
7.5.13	GPS Setup.....	156
7.5.14	Main ARINC 429 Port 3 Configuration.....	158
7.5.15	GPS Legacy Avionics System (GLAS).....	158

7.5.16	<i>GDL Configuration Pages</i>	160
7.5.17	<i>Remote XPDR Configuration</i>	161
7.5.18	<i>Voice Call Outs Configuration</i>	163
7.5.19	<i>Wireless Portables</i>	164
7.5.20	<i>WiFi Setup</i>	164
7.5.21	<i>Bluetooth Setup</i>	165
7.5.22	<i>IRU Calibration, IFD545, IFD550, Atlas</i>	169
7.5.23	<i>RDR2000 Radar Configuration</i>	172
7.5.24	<i>Fixed Wing TAWS enablement and configuration</i>	173
7.5.25	<i>Stormscope Test Page</i>	175
7.5.26	<i>GAD 42 Configuration</i>	176
7.5.27	<i>Other System Diagnostics Pages</i>	177
7.6	<i>Checkout</i>	179
7.6.1	<i>Database Check</i>	179
7.6.2	<i>Airplane Flight Supplement Check</i>	179
7.6.3	<i>Instructions for Continued Airworthiness</i>	179
7.6.4	<i>Aircraft Weight and Balance</i>	179
7.6.5	<i>Electrical Load Analysis</i>	179
7.6.6	<i>GPS Signal Acquisition</i>	179
7.6.7	<i>VHF COM Checkout</i>	180
7.6.8	<i>VOR/LOC/ GS Checkout</i>	180
7.6.9	<i>Autopilot</i>	180
7.6.10	<i>Magnetic Compass Swing</i>	181
7.6.11	<i>IFD Bezel and Display Lighting</i>	181
7.6.12	<i>External Annunciators and Switches</i>	181
7.6.13	<i>Placards</i>	181
7.6.14	<i>Self-test Page</i>	181
7.6.15	<i>Dual IFD Configuration</i>	182

7.6.16	Heading Interface Check	182
7.6.17	ADS-B Output	182
7.6.18	Fixed Wing TAWS Checkout (if enabled)	182
8.	Flight Checks.....	184
8.1	GPS Verification	184
8.2	VHF COM Flight Check	184
8.3	VOR Flight Checks	184
8.4	ILS Flight Checks.....	184
8.5	Autopilot Checks.....	184
8.6	Sensors Verification.....	184
8.7	Fixed Wing TAWS Checks (if enabled)	185
9.	Glove Validation Procedures.....	186
10.	Software and Database Update Procedures.....	187
10.1	Data Updates	187
10.2	Datalogs Download.....	190
10.3	Software Update	192
11.	Periodic Maintenance.....	193
11.1	Equipment Calibration	193
11.2	VOR Checks	193
11.3	Cleaning.....	193
12.	Factory Service Policies and Procedures.....	194
12.1	Technical Support.....	194
12.2	General Service Procedures	194
13.	Bezel and Display Cleaning	196
Appendix A: Environmental Qualification Form.....		197
Appendix B: STC Permission		200

Appendix C: Mechanical Drawings 201

Appendix D: Electrical Interface Drawings 210

Appendix E: Troubleshooting Guide..... 292

Appendix F: Configuration Setup..... 295

Notes to Installers:

The following important issues regarding the Avidyne 700-00182-XXX (IFD5XX), 700-00179-XXX (IFD4XX), 700-00194-XXX (Atlas) Integrated Flight Display GPS/NAV/COM System installation should be noted during the planning stages.

- 1. These installation instructions assume that the GPS/NAV/COM transceiver and GPS antenna can be installed in a structurally sound manner in accordance with the installation manual and AC 43.13-(). All the aircraft certification requirements must remain in compliance.**
- 2. Mounting the GPS antenna on composite and pressurized aircraft requires engineering guidance beyond the scope of this manual. With respect to the Approved Model List STC, the physical mounting of the antenna is specifically excluded from the approval in the case of installations on the pressure vessel of pressurized aircraft, composite aircraft, and aircraft with a certification basis of Amendment 23-45 or later, unless approved installation data is listed in the Master Document List of the STC. All early amendment, metal construction, non-pressurized aircraft antenna installations must be installed consistent with accepted industry practices. The installation must be structurally sound and in accordance with FAA Advisory Circular 43.13-1B and 43.13-2B. All other antennas must be mounted using the manufacturers' installation data.**
- 3. An Electrical Load Analysis must be accomplished to determine that the electrical limits of the specific aircraft are not exceeded. The Electrical Load Analysis, Functional Hazard Assessment and other certification requirements for the aircraft must remain in compliance.**
- 4. The IFD5XX/IFD4XX/ATLAS Forward Looking Terrain Alerting is not a TSO-C151 system, and does not satisfy any Part 91/135 TAWS requirements.**
- 5. Prior to starting IFD5XX/IFD4XX/ATLAS installation, verify the aircraft make and model is on the STC Approved Model List (AML). Also, note any installation specific data for the make and model in the AML.**
- 6. IFD545, IFD550, and ATLAS may not be stored, or installed in any aircraft that is expected to be stored, in areas where the temperature is expected to be below -40°C**
- 7. IFD545, IFD550, and ATLAS cannot be used as a required attitude indicator and must only be used as a "secondary (non -required) source of attitude information".**
- 8. This Installation Manual is applicable to fixed wing applications only. For Rotorcraft Part 27/29 reference the IFD5XX/4XX Helicopter Installation Manual 600-00333-000.**

1. General Information

1.1 Introduction

This manual contains information about the physical, mechanical, and electrical characteristics of the Avidyne GPS/Navigation/Communication Integrated Flight Display (IFD) and provides installation instructions for its components. This manual covers the following IFD configurations, IFD4XX Series p/n 700-00179-XXX, IFD5XX Series p/n 700-00182-XXX and Atlas Series 700-00194-XXX. These IFD configurations will be referred to generically as “IFD” throughout this manual unless specific configurations or models are identified.

1.2 IFD Configurations

This manual applies to the following part numbers in Table 1, Table 2 and Table 3

Model Number	Hardware Part Number	Software Part Number (or later approved revision)
IFD510 (Black Bezel)	700-00182-010	ACR: 530-00246-000 Rev. 00
IFD510 with Video (Black Bezel)	700-00182-011	<ul style="list-style-type: none"> • 510-00348-000 Rev. 00
IFD510 (Grey Bezel)	700-00182-110	<ul style="list-style-type: none"> • 510-00349-000 Rev. 00
IFD510 with Video (Grey Bezel)	700-00182-111	<ul style="list-style-type: none"> • 510-00310-000 Rev. 01
IFD510 (Black Bezel)	700-00182-210	<ul style="list-style-type: none"> • 510-00311-001 Rev. 00
IFD510 with Video (Black Bezel)	700-00182-211	<ul style="list-style-type: none"> • 510-00312-000 Rev. 07
IFD510 (Grey Bezel)	700-00182-310	<ul style="list-style-type: none"> • 510-00346-000 Rev. 04
IFD510 with Video (Grey Bezel)	700-00182-311	FPSM: 530-00226-000 Rev. 05
IFD510 (Black Bezel)	700-00182-710	<ul style="list-style-type: none"> • 510-00294-000 Rev. 05
IFD510 with Video (Black Bezel)	700-00182-711	<ul style="list-style-type: none"> • 510-00291-000 Rev. 00
IFD510 (Grey Bezel)	700-00182-810	LIO App: 530-00239-000 Rev. 07
IFD510 with Video (Grey Bezel)	700-00182-811	<ul style="list-style-type: none"> • 510-00328-000 Rev. 00 • 510-00329-000 Rev. 08
IFD540 (Black Bezel)	700-00182-000	LIO I/O: 530-00238-000 Rev. 07
IFD540, 16W (Black Bezel)	700-00182-002	<ul style="list-style-type: none"> • 510-00343-000 Rev. 02
IFD540 with Video (Black Bezel)	700-00182-001	<ul style="list-style-type: none"> • 510-00289-000 Rev. 01
IFD540 (Grey Bezel)	700-00182-100	<ul style="list-style-type: none"> • 510-00290-000 Rev. 02
IFD540, 16W (Grey Bezel)	700-00182-102	<ul style="list-style-type: none"> • 510-00291-000 Rev. 00
IFD540 with Video (Grey Bezel)	700-00182-101	GPS: 530-00229-000 Rev. 09
IFD540 (Black Bezel)	700-00182-200	<ul style="list-style-type: none"> • 510-00876-000 Rev. 08
IFD540 with Video (Black Bezel)	700-00182-201	<ul style="list-style-type: none"> • 510-00877-000 Rev. 02
IFD540 (Grey Bezel)	700-00182-300	VHF: 530-00231-000 Rev. 05
IFD540 with Video (Grey Bezel)	700-00182-301	NOTE: Not Installed in IFD510, IFD545
IFD540 (Black Bezel)	700-00182-700	<ul style="list-style-type: none"> • 510-00314-000 Rev. 00
IFD540 with Video (Black Bezel)	700-00182-701	<ul style="list-style-type: none"> • 510-00239-001 Rev. 00
IFD540 (Grey Bezel)	700-00182-800	
IFD540 with Video (Grey Bezel)	700-00182-801	

IFD545 (Black Bezel)	700-00182-030	<ul style="list-style-type: none"> • 510-00316-000 Rev. 06 • 510-00237-000 Rev. 00 ARS: 530-00223-000 Rev. 00 NOTE: Installed in IFD545 and IFD550 <ul style="list-style-type: none"> • 510-00283-000 Rev. 01 • 510-00332-000 Rev. 00
IFD545 with Video (Black Bezel)	700-00182-031	
IFD545 (Grey Bezel)	700-00182-130	
IFD545 with Video (Grey Bezel)	700-00182-131	
IFD545 (Black Bezel)	700-00182-230	
IFD545 with Video (Black Bezel)	700-00182-231	
IFD545 (Grey Bezel)	700-00182-330	
IFD545 with Video (Grey Bezel)	700-00182-331	
IFD545 (Black Bezel)	700-00182-730	
IFD545 with Video (Black Bezel)	700-00182-731	
IFD545 (Grey Bezel)	700-00182-830	
IFD545 with Video (Grey Bezel)	700-00182-831	
IFD550 (Black Bezel)	700-00182-020	
IFD550 with Video (Black Bezel)	700-00182-021	
IFD550 (Grey Bezel)	700-00182-120	
IFD550 with Video (Grey Bezel)	700-00182-121	
IFD550 (Black Bezel)	700-00182-220	
IFD550 with Video (Black Bezel)	700-00182-221	
IFD550 (Grey Bezel)	700-00182-320	
IFD550 with Video (Grey Bezel)	700-00182-321	
IFD550 (Black Bezel)	700-00182-720	
IFD550 with Video (Black Bezel)	700-00182-721	
IFD550 (Grey Bezel)	700-00182-820	
IFD550 with Video (Grey Bezel)	700-00182-821	

Table 1 IFD5XX Variants

Model Number	Hardware Part Number	Software Part Number (or later approved revision)
IFD410 (Black Bezel)	700-00179-010	ACR: 530-00246-000 Rev. 00 <ul style="list-style-type: none"> • 510-00348-000 Rev. 00 • 510-00349-000 Rev. 00 • 510-00310-000 Rev. 01 • 510-00311-001 Rev. 00 • 510-00312-000 Rev. 07 • 510-00346-000 Rev. 04 FPSM: 530-00226-000 Rev. 05 <ul style="list-style-type: none"> • 510-00294-000 Rev. 05 • 510-00291-000 Rev. 00 LIO App: 530-00239-000 Rev. 07 <ul style="list-style-type: none"> • 510-00328-000 Rev. 00 • 510-00329-000 Rev. 08 LIO I/O: 530-00238-000 Rev. 07 <ul style="list-style-type: none"> • 510-00343-000 Rev. 02 • 510-00289-000 Rev. 01 • 510-00290-000 Rev. 02 • 510-00291-000 Rev. 00 GPS: 530-00229-000 Rev. 09 <ul style="list-style-type: none"> • 510-00876-000 Rev. 08 • 510-00877-000 Rev. 02 VHF: 530-00231-000 Rev. 05 NOTE: Not Installed in IFD410 <ul style="list-style-type: none"> • 510-00314-000 Rev. 00 • 510-00239-001 Rev. 00 • 510-00316-000 Rev. 06 • 510-00237-000 Rev. 00
IFD410 (Grey Bezel)	700-00179-110	
IFD410 (Black Bezel)	700-00179-210	
IFD410 (Grey Bezel)	700-00179-310	
IFD410 (Black Bezel)	700-00179-710	
IFD410 (Grey Bezel)	700-00179-810	
IFD440 (Black Bezel)	700-00179-000	GPS: 530-00229-000 Rev. 09 <ul style="list-style-type: none"> • 510-00876-000 Rev. 08 • 510-00877-000 Rev. 02 VHF: 530-00231-000 Rev. 05 NOTE: Not Installed in IFD410 <ul style="list-style-type: none"> • 510-00314-000 Rev. 00 • 510-00239-001 Rev. 00 • 510-00316-000 Rev. 06 • 510-00237-000 Rev. 00
IFD440 (Grey Bezel)	700-00179-100	
IFD440 (Black Bezel)	700-00179-200	
IFD440 (Grey Bezel)	700-00179-300	
IFD440 (Black Bezel)	700-00179-700	
IFD440 (Grey Bezel)	700-00179-800	

Table 2 IFD4XX Variants

Model Number	Hardware Part Number	Software Part Number (or later approved revision)
		ACR: 530-00246-000 Rev. 00 <ul style="list-style-type: none"> • 510-00348-000 Rev. 00 • 510-00349-000 Rev. 00 • 510-00310-000 Rev. 01 • 510-00311-001 Rev. 00 • 510-00312-000 Rev. 07 • 510-00346-000 Rev. 04 FPSM: 530-00226-000 Rev. 05 <ul style="list-style-type: none"> • 510-00294-000 Rev. 05 • 510-00291-000 Rev. 00
Atlas (Black Bezel) W/VHF	700-00194-020	LIO App: 530-00239-000 Rev. 07
Atlas (Black Bezel) W/VHF & Video	700-00194-021	<ul style="list-style-type: none"> • 510-00328-000 Rev. 00 • 510-00329-000 Rev. 08
Atlas (Black Bezel) FMS Only	700-00194-030	LIO I/O: 530-00238-000 Rev. 07
Atlas(Black Bezel)FMS Only & Video	700-00194-031	<ul style="list-style-type: none"> • 510-00343-000 Rev. 02 • 510-00289-000 Rev. 01
Atlas (Grey Bezel) W/VHF	700-00194-120	<ul style="list-style-type: none"> • 510-00290-000 Rev. 02 • 510-00291-000 Rev. 00
Atlas (Grey Bezel) W/VHF & Video	700-00194-121	GPS: 530-00229-000 Rev. 08
Atlas (Grey Bezel) FMS Only	700-00194-130	<ul style="list-style-type: none"> • 510-00876-000 Rev. 07 • 510-00877-000 Rev. 02
Atlas(Grey Bezel)FMS Only & Video	700-00194-131	VHF: 530-00231-000 Rev. 05
		NOTE: Not Installed in FMS only Atlas
		<ul style="list-style-type: none"> • 510-00314-000 Rev. 00 • 510-00239-001 Rev. 00 • 510-00316-000 Rev. 06 • 510-00237-000 Rev. 00
		ARS: 530-00223-000 Rev. 00
		<ul style="list-style-type: none"> • 510-00283-000 Rev. 01 • 510-00332-000 Rev. 00

Table 3 Atlas Variants

1.3 Bendix King Part Numbers

BendixKing Part Number	Manufacture Part Number	Product Description
89000039-001	700-00182-700	AeroNav 900,10W, GPS/Nav/Com/WiFi/BT/FLTA/SVS/--Black
89000039-002	700-00182-701	AeroNav 900, 10W, GPS/Nav/Com/WiFi/BT/FLTA/SVS//RS170
89000039-003	850-00182-700	Ship Kit, AeroNav 900,10W, GPS/Nav/Com/WiFi/BT/FLTA/SVS/--Black
89000039-004	850-00182-701	Ship Kit, AeroNav 900, 10W, GPS/Nav/Com/WiFi/BT/FLTA/SVS//RS170
89000039-007	850-00188-002	Ship Kit, AeroNav 880 & 9XX Install Kit, Fixed Wing (Tray, Backplate, Connectors)
89000039-011	850-00182-730	Ship Kit, AeroNav 905, GPS/WiFi/BT/FLTA/SVS/ARS--Black
89000039-012	850-00182-731	Ship Kit, AeroNav 905, GPS/WiFi/BT/FLTA/SVS/ARS/RS170
89000039-013	700-00182-730	AeroNav 905, GPS/WiFi/BT/FLTA/SVS/ARS--Black
89000039-014	700-00182-731	AeroNav 905, GPS/WiFi/BT/FLTA/SVS/ARS/RS170
89000040-001	700-00182-720	AeroNav 910, 10W, GPS/Nav/Com/WiFi/BT/FLTA/SVS/ARS-- Black
89000040-002	700-00182-721	AeroNav 910, 10W, GPS/Nav/Com/WiFi/BT/FLTA/SVS/ARS/RS170
89000040-003	850-00182-720	Ship Kit, AeroNav 910, 10W, GPS/Nav/Com/WiFi/BT/FLTA/SVS/ARS-- Black
89000040-004	850-00182-721	Ship Kit, AeroNav 910, 10W, GPS/Nav/Com/WiFi/BT/FLTA/SVS/ARS/RS170
89000040-005	700-00182-820	AeroNav 910, 10W, GPS/Nav/Com/WiFi/BT/FLTA/SVS/ARS-- Grey
89000040-007	850-00182-820	Ship Kit, AeroNav 910, 10W, GPS/Nav/Com/WiFi/BT/FLTA/SVS/ARS-- Grey
89000041-001	700-00179-700	AeroNav 800, 10W, GPS/Nav/Com/WiFi/BT/FLTA/SVS--Black
89000041-002	850-00179-700	Ship Kit, AeroNav 800, 10W, GPS/Nav/Com/WiFi/BT/FLTA/SVS--Black
89000041-005	850-00184-002	Ship Kit, AeroNav 780 & 800 Install Kit, Fixed Wing (Tray, Backplate, Connectors)
89000041-009	850-00182-710	Ship Kit, AeroNav 880, GPS/WiFi/BT/FLTA/SVS/--Black
89000041-010	850-00182-711	Ship Kit, AeroNav 880, GPS/WiFi/BT/FLTA/SVS//RS170
89000041-012	700-00182-710	AeroNav 880, GPS/WiFi/BT/FLTA/SVS/--Black
89000041-013	700-00182-711	AeroNav 880, GPS/WiFi/BT/FLTA/SVS//RS170
89000045-001	700-00179-710	AeroNav 780, GPS(ONLY)/WiFi/BT/FLTA/SVS-- Black
89000045-003	850-00179-710	Ship Kit, AeroNav 780, GPS(ONLY)/WiFi/BT/FLTA/SVS-- Black
89000046-002	500-00210-000	16W VHF Enablement Factory Activation
89000046-003	500-00232-000	Radar (RDR 2000/RDR 2100) Enablement Factory Activation
89000046-005	500-00277-000	GPS Legacy Avionics Support (GLAS) LPV Enablement Factory Activation
89000046-006	500-00210-002	16W VHF Enablement Field Activation Coupon
89000046-007	500-00232-002	Radar (RDR 2000/RDR 2100) Enablement Field Activation Coupon
89000046-009	500-00277-002	GPS Legacy Avionics Support (GLAS) LPV Enablement Field Activation Coupon
89000046-010	850-00217-001	Antenna, GPS TSO-C190, Hemispherical, TNC Female, White

89000046-011	820-00101-001	Byteflight Cable (20')
TBD	500-00236-001	TAWs Activation

Table 4 Bendix King Part Numbers

1.4 Unit Modifications

The following tables list the hardware modifications since initial release of the IFD5XX (700-00182-XXX), IFD4XX (700-00179-XXX) and Atlas (700-00194-XXX) Navigators.

Modification	Change	Hardware PN	Applicable to Hardware Revision (or earlier)	Compatible with Software Version	HW Release Date
MOD 2	OBS UPDATE	700-00182-000 700-00182-002 700-00182-100 700-00182-102	00 00 00 00	10.0.0.0 or later	9/25/2014
MOD 4	SERIAL DME UPDATE	700-00182-000 700-00182-002 700-00182-100 700-00182-102	02 02 02 02	10.0.3.0 or later	11/21/2014
MOD 5	STANDBY AUDIO IMPLEMENTATION	700-00182-000 700-00182-002 700-00182-100 700-00182-102	03 03 03 03	10.1 or later	12/11/2014
MOD 8	GPS MAXIM B, HIGH GAIN LNA1	700-00182-000 700-00182-002 700-00182-100 700-00182-102	06 06 06 06	10.1 or later	05/05/2015
MOD 11	REPLACEMENT OF MAIN GPS OSCILLATOR	700-00182-000 700-00182-002 700-00182-100 700-00182-102	09 09 09 09	10.1 or later	07/22/2015
MOD 12 (IFD5XX 700-00182-XXX) MOD 3 (IFD4XX 700-00179-XXX)	CHANGE RESOLVER INPUTS TO AC COUPLED	700-00182-000 700-00182-002 700-00182-100 700-00182-102 700-00179-000 700-00179-100	10 10 10 10 02 02	10.1 or later	11/04/2015
MOD 20	ADDS SHIELDING TO VHF CIRCUITS TO ELIMINATE SQUELCH BREAK	700-00182-000 700-00182-001 700-00182-002 700-00182-020 700-00182-021 700-00182-100 700-00182-101 700-00182-102 700-00182-120 700-00182-121	Optional for all Revisions	10.1 or later	08/04/2019

Modification	Change	Hardware PN	Applicable to Hardware Revision (or earlier)	Compatible with Software Version	HW Release Date
		700-00182-200 700-00182-201 700-00182-220 700-00182-221 700-00182-700 700-00182-701 700-00182-720 700-00182-721 700-00182-820 700-00179-000 700-00179-100 700-00179-200 700-00179-700			
MOD 21	Adds RS-170 Video	700-00182-001 700-00182-011 700-00182-021 700-00182-031 700-00182-101 700-00182-111 700-00182-121 700-00182-131 700-00182-201 700-00182-211 700-00182-221 700-00182-231 700-00182-701 700-00182-711 700-00182-721 700-00182-731	Optional for all Revisions	10.1 or later 10.2.5.1 or later	08/20/2019
MOD 22	AVIGPS Boot flash chip replacement	700-00182-000 700-00182-001 700-00182-002 700-00182-010 700-00182-011 700-00182-020 700-00182-021 700-00182-030 700-00182-031 700-00182-100 700-00182-101 700-00182-102 700-00182-120 700-00182-121 700-00182-130 700-00182-131 700-00182-700	17 03 14 03 03 03 03 03 03 03 17 03 15 03 03 03 03 17	10.1 or later	03/20/2020

Modification	Change	Hardware PN	Applicable to Hardware Revision (or earlier)	Compatible with Software Version	HW Release Date
		700-00182-701 700-00182-710 700-00182-711 700-00182-720 700-00182-721 700-00182-730 700-00182-731 700-00179-000 700-00179-010 700-00179-100 700-00179-110 700-00179-700 700-00179-710	03 03 03 03 03 03 03 09 02 09 02 09 02		
			Note: Above revisions with 320-00225-003 REV 02 GPS or later already include MOD		
MOD 25	Clock Mismatch	700-00182-000 700-00182-001 700-00182-002 700-00182-010 700-00182-011 700-00182-020 700-00182-021 700-00182-030 700-00182-031 700-00182-100 700-00182-101 700-00182-102 700-00182-110 700-00182-111 700-00182-120 700-00182-121 700-00182-130 700-00182-131 700-00182-700 700-00182-701 700-00182-710 700-00182-711 700-00182-720 700-00182-721 700-00182-730 700-00182-731 700-00179-000	18 04 14 04 04 04 04 04 04 04 18 04 15 04 04 04 04 04 04 04 18 04 04 04 04 04 04 04 04 04 10	10.2 or later	07/10/2021

Modification	Change	Hardware PN	Applicable to Hardware Revision (or earlier)	Compatible with Software Version	HW Release Date
		700-00179-010	02		
		700-00179-100	10		
		700-00179-110	02		
		700-00179-700	10		
		700-00179-710	02		
MOD 26	ACR With Single 9S12	700-00182-000	19	10.3 or later	04/22
		700-00182-001	05		
		700-00182-002	14		
		700-00182-010	05		
		700-00182-011	05		
		700-00182-020	05		
		700-00182-021	05		
		700-00182-030	05		
		700-00182-031	05		
		700-00182-100	19		
		700-00182-101	05		
		700-00182-102	15		
		700-00182-110	05		
		700-00182-111	05		
		700-00182-120	05		
		700-00182-121	05		
		700-00182-130	05		
		700-00182-131	05		
		700-00182-200	18		
		700-00182-201	04		
		700-00182-210	04		
		700-00182-211	04		
		700-00182-220	04		
		700-00182-221	04		
		700-00182-230	04		
		700-00182-231	04		
		700-00182-700	19		
		700-00182-701	05		
		700-00182-710	05		
		700-00182-711	05		
		700-00182-720	05		
		700-00182-721	05		
		700-00182-730	05		
		700-00182-731	05		
		700-00182-820	05		
		700-00179-000	11		
		700-00179-010	03		
		700-00179-100	11		
		700-00179-110	03		
		700-00179-700	11		
		700-00179-710	03		

Modification	Change	Hardware PN	Applicable to Hardware Revision (or earlier)	Compatible with Software Version	HW Release Date
		700-00194-020	01		
		700-00194-021	01		
		700-00194-120	01		
		700-00194-121	01		
MOD 27	9S12 REPLACEMENT	700-00182-000	19	10.3 or later	04/22
		700-00182-001	05		
		700-00182-002	14		
		700-00182-010	05		
		700-00182-011	05		
		700-00182-020	05		
		700-00182-021	05		
		700-00182-030	05		
		700-00182-031	05		
		700-00182-100	19		
		700-00182-101	05		
		700-00182-102	15		
		700-00182-110	05		
		700-00182-111	05		
		700-00182-120	05		
		700-00182-121	05		
		700-00182-130	05		
		700-00182-131	05		
		700-00182-200	18		
		700-00182-201	04		
		700-00182-210	04		
		700-00182-211	04		
		700-00182-220	04		
		700-00182-221	04		
		700-00182-230	04		
		700-00182-231	04		
		700-00182-700	19		
		700-00182-701	05		
		700-00182-710	05		
		700-00182-711	05		
		700-00182-720	05		
		700-00182-721	05		
		700-00182-730	05		
		700-00182-731	05		
		700-00182-820	05		
		700-00179-000	11		
		700-00179-010	03		
		700-00179-100	11		
		700-00179-110	03		
		700-00179-700	11		
		700-00179-710	03		
		700-00194-020	01		

Modification	Change	Hardware PN	Applicable to Hardware Revision (or earlier)	Compatible with Software Version	HW Release Date
		700-00194-021 700-00194-120 700-00194-121	01 01 01		

Table 5 IFD5XX (700-00182-XXX) / IFD4XX (700-00179-XXX) / Atlas (700-00194-XXX) Modification History

1.5 Technical Specifications

This section gives mechanical and electrical characteristics for the IFD5XX, IFD4XX, and Atlas

1.5.1 IFD5XX Specifications

The IFD5XX unit has the following characteristics:

1.5.1.1 IFD5XX Physical and Electrical Specifications

Physical Specifications					
Bezel Height	4.58 inches (116 mm)				
Bezel Width	6.25 inches (159 mm)				
Depth (w/Connectors)	11.00 inches (279 mm)				
Weight	Table 11 IFD Installed Weights				
Connectors (Aircraft Mating Connector)	P1001/P1050 - 78-position High Density D-Subminiature (male) P1002- 25-position Standard D-Subminiature (female) P1006- 44-position High Density D-Subminiature (male)				
Electrical Requirements					
Voltage	9-33 VDC				
Current	Note 1: Max current listed includes max display brightness and max USB charging currents. Note 2: VHF Tx power steps down based on input voltage starting at 18V				
		Max Current (ADC) by Model			
Input Voltage	Power Circuit	IFD550	IFD545	IFD540	IFD510
28VDC Nominal	Main-Pwr, (P1001)	2.07	2.07	1.90	1.90
	Com-Pwr, (P1002), No Tx	0.47	n/a	0.47	n/a
	Com-Pwr, (P1002), 10W Tx	3.93	n/a	3.93	n/a
	Com-Pwr, (P1002), 16W Tx	4.66	n/a	4.66	n/a
	Nav-Pwr, (P1006)	1.15	n/a	1.15	n/a
18VDC Emergency operating low for 28V aircraft	Main-Pwr, (P1001)	3.12	3.12	2.90	2.90
	Com-Pwr, (P1002), No Tx	0.71	n/a	0.71	n/a
	Com-Pwr, (P1002), 10W Tx	5.09	n/a	5.09	n/a
	Com-Pwr, (P1002), 16W Tx	5.09	n/a	5.09	n/a
	Nav-Pwr, (P1006)	0.74	n/a	0.74	n/a
14VDC Nominal	Main-Pwr, (P1001)	3.62	3.62	3.34	3.34
	Com-Pwr, (P1002), No Tx	0.89	n/a	0.89	n/a
	Com-Pwr, (P1002), 10W Tx	6.84	n/a	6.84	n/a
	Com-Pwr, (P1002), 16W Tx	6.84	n/a	6.84	n/a
	Nav-Pwr, (P1006)	0.58	n/a	0.58	n/a
9VDC Emergency operating low for 14V aircraft	Main-Pwr, (P1001)	4.03	4.03	3.68	3.68
	Com-Pwr, (P1002), No Tx	1.43	n/a	1.43	n/a
	Com-Pwr, (P1002), 10W Tx	9.20	n/a	9.20	n/a
	Com-Pwr, (P1002), 16W Tx	9.20	n/a	9.20	n/a
	Nav-Pwr, (P1006)	0.37	n/a	0.37	n/a

Dimming Bus	28VDC/14VDC/5VDC/5VAC
Cooling Requirements	Not Required
Operating Limits	Reference Appendix A: Environmental Qualification Form

Table 6 IFD5XX Specifications

1.5.1.2 IFD5XX Display Specifications

Display Size	5.7 inches diagonal
Active Area	4.53 inches (w) x 3.40 inches (h)
Resolution	640x480 pixels
Viewing Angle	<p>IFD5XX Designed and Tested Limits:</p> <p>Left/Right: 45° Up: 35° Down: 15°</p> <p>LCD Specification:</p> <p>Left/Right: 80° Up: 80° Down: 60°</p>

Table 7 IFD5XX Display Specifications

1.5.1.3 IFD5XX GPS Specifications

Channels	16 channels (13 GPS, 3 GPS/WAAS/SBAS)
Velocity	1000 knots maximum (below 60,000 ft)
TTFF (Time to First Fix)	150 seconds
Reacquisition	20 seconds
Position Update Interval	0.2 seconds (5 Hz)
PPS Signal (Time Mark)	(UTC Epoch) +100ns ± 50ns over all conditions 1 sec ±75ns between pulses
Lat/Long Position Accuracy	3.4 meters
Fault Detection/RAIM	RAIM/FDE WAAS Beta 3 Compliant @ 5 Hz
Sensitivity	-123 dBm
GPS System Design Assurance (SDA)	DO-178B Level B, DO-254 Level B
GPS Source Integrity Level (SIL)	3 - Enroute
Source Integrity Level Supplement (SIL _{SUPP})	0 - "per hour"
Navigation Accuracy Category Velocity (NAC _v)	<p>Category 3 [< 1 m/s]</p> <p>ADS-B installations should use a NAC_v of 1 unless GPS tests support a higher category. The AXP340 requires a NAC_v of Category 1 [< 10 m/s] or better.</p>
Receiver Class	TSO-C146d Class Gamma 3 receiver that complies with AC 20-138C

Table 8 IFD5XX GPS Specifications

1.5.1.4 IFD540, IFD550 VHF Communication Transceiver Specification

Audio Output	65 mW into 150Ω load
Audio Response	<6dB Variation from 350 to 2500 Hz, 4kHz -18dB
AGC Characteristics	<6dB Variation from 10uV to 10mV
Sensitivity	4uV (6dB (S+N)/N 30% mod @ 1KHz)
Spurious Response	10mV spurious signal produces no more output than a desired signal at 6dB (S+N)/N
Transmitter Power	16W or 10W @ 28V, 10W @ 14V (Typical)
Transmitter Duty Cycle	Recommended 10% maximum
Modulation Capability	70%
Carrier Noise Level	-39dB (S+N)/N
Frequency Stability	< 2.5 ppm
Demodulation Audio Distortion	<12% @ 70% modulation
Sidetone Fidelity	300-2500 Hz
Demodulation Audio Response	<6dB Variation from 300 to 2500 Hz

Table 9 VHF Communication Transceiver Specifications

1.5.1.5 IFD545, IFD550 ARS (Inertial Reference) Specifications

Attitude Static Accuracy	± 1.0 degree
Attitude Dynamic and Flight Accuracy	± 2.5 degrees
Slip output	Provided
Heading, Turn Rate, and Standard Turn Bank Angle Outputs	Not provided

Table 10 ARS Specification IFD5XX Installed unit weight in pounds

Unit	Unit Weight	Installed Weight Without Backshells (Less Wiring)	Installed Weight with Backshells (Less Wiring)
IFD510	5.65	7.04 ±.25lbs	7.52 ±.25lbs
IFD540	6.75	8.38 ±.25lbs	9.20 ±.25lbs
IFD545	6.00	7.39 ±.25lbs	7.87 ±.25lbs
IFD550	7.15	8.78 ±.25lbs	9.60 ±.25lbs

Table 11 IFD Installed Weights

1.5.1.6 IFD540, IFD550 VHF Navigation Specification

Glideslope Receiver	-
Selectivity	0 ± .0091 ddm w/ test signal varied ± 17kHz. 60dB for ± 132kHz offset
Sensitivity (flag)	10uV max
Spurious Response	<-60 dB
Centering Accuracy	0 ± 0.02 DDM or better
Deflection Response	67% of final value in 600msec
Localizer Receiver	-
Selectivity	6dB at least ±17kHz, 40dB no more than ±80kHz
Sensitivity (flag)	10uV max
Sensitivity (aural)	10uV max for 20dB (S+N)/N with 1kHz 30%mod
Centering Accuracy	+/-3mV
Deflection Response	67% of final value in 600msec
Audio Response	<6dB Variation from 350 to 2500 Hz, -20dB <150Hz >9kHz

Table 12 VHF Navigation Specification

Avidyne Navigation Capabilities

Note 5

Note 3

Note 4

Note 2

Note 1

Spec	RNP 10	RNAV 5 GNSS	RNAV5 DME/DME	RNAV 5 VOR/DME	RNAV 2 GNSS (note 1)	RNAV 1 GNSS	RNP 4	RNP 1 GNSS	RNP APCH	RNP APCH w/ Baro VNAV	RNP AR APCH w/ RF (note3)	RNP AR APCH w/o RF (note3)
IFD4XX/5XX/Helios Navigation mode	Oceanic	Enroute			Enroute	Terminal	Oceanic	Terminal	Approach			
Procedure type	N/A	N/A			Arrivals, Departure	Arrivals, Departures, Approaches	N/A	Arrival, Departures, Approaches	LNAV, LNAV/VNAV LP, LPV			
ICAO Flight Plan Code	A1	B2	B3	B4	C2	D2	L1	O2	S1	S2	T1	T2
IFD4XX/5XX/Helios Capability	Yes	Yes	No	No	Yes	Yes	Yes	Yes	Yes (Note 5)	No	No	No

Note 1

RNAV1 requires total system error of not more than 1NM for 95% of the total flight time

Note 2

RNAV2 requires total system error of not more than 2NM for 95% of the total flight time

Note 3

GNSS sensor complies with AC 20-138. GNSS accuracy better than 36m 95%, SBAS GNSS accuracy is better than 2m 95%

Note 4

This table is intended to show certifications of avionics equipment. Capabilities shown do not constitute operational approval.

Note 5

LP and LPV guidance require SBAS, IFD4XX/5XX/Helios must be connected to an approved SBAS (e.g. WAAS) antenna.

Table 13 IFD4XX/5XX/Helios GPS Navigation Capabilities

IFD4XX Specifications

The IFD4XX unit has the following characteristics:

1.5.1.7 IFD4XX Physical and Electrical Specifications

Physical Specifications			
Bezel Height	2.66 inches (67 mm)		
Bezel Width	6.25 inches (159 mm)		
Depth (w/Connectors)	11.00 inches (279 mm)		
Weight	Table 15 IFD Installed Weights		
Connectors (Aircraft Mating Connector)	P1001 - 78-position High Density D-Subminiature (male) P1002- 25-position Standard D- Subminiature (female) P1006- 44-position High Density D- Subminiature (male)		
Electrical Requirements			
Voltage	9-33 VDC		
Current			
Note 1: Max current listed includes max display brightness and max USB charging currents.			
Note 2: VHF Tx power steps down based on input voltage starting at 18V			
Input Voltage		Max Current (ADC) by Model	
Power Circuit		IFD440	IFD410
28VDC Nominal	Main-Pwr, (P1001)	1.67	1.67
	Com-Pwr, (P1002), No Tx	0.47	n/a
	Com-Pwr, (P1002), 10W Tx	3.93	n/a
	Com-Pwr, (P1002), 16W Tx	4.66	n/a
	Nav-Pwr, (P1006)	1.15	n/a
18VDC Emergency operating low for 28V aircraft	Main-Pwr, (P1001)	2.53	2.53
	Com-Pwr, (P1002), No Tx	0.71	n/a
	Com-Pwr, (P1002), 10W Tx	5.09	n/a
	Com-Pwr, (P1002), 16W Tx	5.09	n/a
	Nav-Pwr, (P1006)	0.74	n/a
14VDC Nominal	Main-Pwr, (P1001)	2.88	2.88
	Com-Pwr, (P1002), No Tx	0.89	n/a
	Com-Pwr, (P1002), 10W Tx	6.84	n/a
	Com-Pwr, (P1002), 16W Tx	6.84	n/a
	Nav-Pwr, (P1006)	0.58	n/a
9VDC Emergency operating low for 14V aircraft	Main-Pwr, (P1001)	4.39	4.39
	Com-Pwr, (P1002), No Tx	1.43	n/a
	Com-Pwr, (P1002), 10W Tx	9.20	n/a
	Com-Pwr, (P1002), 16W Tx	9.20	n/a
	Nav-Pwr, (P1006)	0.37	n/a
Dimming Bus	28VDC/14VDC/5VDC/5VAC		
Cooling Requirements	Not Required		
Operating Limits	Reference Appendix A: Environmental Qualification Form		

Table 14 IFD4XX Specifications

1.5.1.8 IFD4XX Installed unit weight in pounds

Unit	Unit Weight	Installed Weight Without Backshells (Less Wiring)	Installed Weight with Backshells (Less Wiring)
IFD410	4.00	4.81 ±.25lbs	5.05 ±.25lbs
IFD440	5.16	6.21 ±.25lbs	6.78 ±.25lbs

Table 15 IFD Installed Weights

1.5.1.9 IFD4XX Display Specifications

Display Size	4.8 inches diagonal
Active Area	4.53 inches (w) x 1.70 inches (h)
Resolution	640x480 pixels
Viewing Angle	<p>IFD4XX Designed and Tested Limits:</p> <p>Left/Right: 45° Up: 35° Down: 15°</p> <p>LCD Specification:</p> <p>Left/Right: 80° Up: 80° Down: 60°</p>

Table 16 IFD4XX Display Specifications

1.5.1.10 IFD4XX GPS Specifications

Channels	16 channels (13 GPS, 3 GPS/WAAS/SBAS)
Velocity	1000 knots maximum (below 60,000 ft)
TTFF (Time to First Fix)	150 seconds
Reacquisition	20 seconds
Position Update Interval	0.2 seconds (5 Hz)
PPS Signal (Time Mark)	(UTC Epoch) +100ns ± 50ns over all conditions 1 sec ± 75ns between pulses
Lat/Long Position Accuracy	3.4 meters
Fault Detection/RAIM	RAIM/FDE WAAS Beta 3 Compliant @ 5 Hz
Sensitivity	-123 dBm
GPS System Design Assurance (SDA)	DO-178B Level B, DO-254 Level B
GPS Source Integrity Level (SIL)	3 - Enroute
Source Integrity Level Supplement (SIL _{SUPP})	0 - "per hour"
Navigation Accuracy Category Velocity (NAC _v)	Category 3 [< 1 m/s] ADS-B installations should use a NAC _v of 1 unless GPS tests support a higher category. The AXP340 requires a NAC _v of Category 1 [< 10 m/s] or better.
Receiver Class	TSO-C146d Class Gamma 3 receiver that complies with AC 20-138C

Table 17 IFD4XX GPS Specifications

1.5.1.11 IFD440 VHF Communication Transceiver Specifications

Audio Output	65 mW into 150Ω load
Audio Response	<6dB Variation from 350 to 2500 Hz, 4kHz -18dB
AGC Characteristics	<6dB Variation from 10uV to 10mV
Sensitivity	4uV (6dB (S+N)/N 30% mod @ 1KHz)
Spurious Response	10mV spurious signal produces no more output than a desired signal at 6dB (S+N)/N
Transmitter Power	16W or 10W @ 28V, 10W @ 14V (Typical)
Transmitter Duty Cycle	Recommended 10% maximum
Modulation Capability	70%
Carrier Noise Level	-39dB (S+N)/N
Frequency Stability	<2.5 ppm
Demodulation Audio Distortion	<12% @ 70% modulation
Sidetone Fidelity	300-2500 Hz
Demodulation Audio Response	<6dB Variation from 300 to 2500 Hz

Table 18 VHF Communication Transceiver Specifications

1.5.1.12 IFD440 VHF Navigation Specification

Glideslope Receiver	-
Selectivity	0 ± .0091 ddm w/ test signal varied ± 17kHz. 60dB for ± 132kHz offset
Sensitivity (flag)	10uV max
Spurious Response	<-60 dB
Centering Accuracy	0 ± 0.02 DDM or better
Deflection Response	67% of final value in 600msec
Localizer Receiver	-
Selectivity	6dB at least ±17kHz, 40dB no more than ±80kHz
Sensitivity (flag)	10uV max
Sensitivity (aural)	10uV max for 20dB (S+N)/N with 1kHz 30%mod
Centering Accuracy	± 3mV
Deflection Response	67% of final value in 600msec
Audio Response	<6dB Variation from 350 to 2500 Hz, -20dB <150Hz >9kHz

Table 19 VHF Navigation Specification

1.5.2 Atlas Specifications

The Atlas unit has the following characteristics:

1.5.2.1 Atlas Physical and Electrical Specifications

Physical Specifications		
Bezel Height	7.50 inches	
Bezel Width	5.75 inches	
Depth (w/Connectors)	11.00 inches	
Weight	Table 25 Atlas Installed Weights	
Connectors (Aircraft Mating Connector)	P1001/P1050 – 78-position HD D-Subminiature (male) Note: P1050 connector is keyed blocking pins 19, 20, 32, 33, 46 and 47 for connector orientation purposes. P1002- 25-position Standard D- Subminiature (female) P1006- 44-position HD D-Subminiature (male)	
Electrical Requirements		
Voltage	9-33 VDC	
Current Note 1: Max current listed includes max display brightness and max USB charging currents. Note 2: VHF Tx power steps down based on input voltage starting at 18V		
		Max Current (ADC) by Model
Input Voltage	Power Circuit	Atlas / Atlas FMS Only
28VDC	Main-Pwr, (P1001)	2.11 / 2.11
	Com-Pwr, (P1002), No Tx	0.47 / N/A
	Com-Pwr, (P1002), 10W Tx	3.93 / N/A
	Com-Pwr, (P1002), 16W Tx	4.66 / N/A
	Nav-Pwr, (P1006)	1.15 / N/A
18VDC Emergency operating low for 28V aircraft	Main-Pwr, (P1001)	3.28 / 3.28
	Com-Pwr, (P1002), No Tx	0.71 / N/A
	Com-Pwr, (P1002), 10W Tx	5.09 / N/A
	Com-Pwr, (P1002), 16W Tx	5.09 / N/A
	Nav-Pwr, (P1006)	0.74 / N/A
14VDC	Main-Pwr, (P1001)	4.00 / 4.00
	Com-Pwr, (P1002), No Tx	0.89 / N/A
	Com-Pwr, (P1002), 10W Tx	6.84 / N/A
	Com-Pwr, (P1002), 16W Tx	6.84 / N/A
	Nav-Pwr, (P1006)	0.58 / N/A
9VDC Emergency operating low for 14V aircraft	Main-Pwr, (P1001)	4.03 / 4.03
	Com-Pwr, (P1002), No Tx	1.43 / N/A
	Com-Pwr, (P1002), 10W Tx	9.20 / N/A
	Com-Pwr, (P1002), 16W Tx	9.20 / N/A
	Nav-Pwr, (P1006)	0.37 / N/A
Dimming Bus	28VDC/14VDC/5VDC/5VAC	
Cooling Requirements	Not Required	
Operating Limits	Reference Appendix A: Environmental Qualification Form	

Table 20 Atlas Specifications

1.5.2.2 Atlas Display Specifications

Display Size	5.7 inches diagonal
Active Area	4.53 inches (w) x 3.40 inches (h)
Resolution	640x480 pixels
Viewing Angle	Atlas Designed and Tested Limits: Left/Right: 45° Up: 15° Down: 35° LCD Specification: Left/Right: 80° Up: 60° Down: 80°

Table 21 Atlas Display Specifications

1.5.2.3 Atlas GPS Specifications

Channels	16 channels (13 GPS, 3 GPS/WAAS/SBAS)
Velocity	1000 knots maximum (below 60,000 ft)
TTFF (Time to First Fix)	150 seconds
Reacquisition	20 seconds
Position Update Interval	0.2 seconds (5 Hz)
PPS Signal (Time Mark)	(UTC Epoch) +100ns ± 50ns over all conditions 1 sec ±75ns between pulses
Lat/Long Position Accuracy	3.4 meters
Fault Detection/RAIM	RAIM/FDE WAAS Beta 3 Compliant @ 5 Hz
Sensitivity	-123 dBm
GPS System Design Assurance (SDA)	DO-178B Level B, DO-254 Level B
GPS Source Integrity Level (SIL)	3 - Enroute
Source Integrity Level Supplement (SIL _{SUPP})	0 - "per hour"
Navigation Accuracy Category Velocity (NAC _v)	Category 3 [< 1 m/s] ADS-B installations should use a NAC _v of 1 unless GPS tests support a higher category. The AXP340 requires a NAC _v of Category 1 [< 10 m/s] or better.
Receiver Class	TSO-C146d Class Gamma 3 receiver that complies with AC 20-138C

Table 22 Atlas GPS Specifications

1.5.2.4 Atlas w/VHF Communication Transceiver Specification

Audio Output	65 mW into 150Ω load
Audio Response	<6dB Variation from 350 to 2500 Hz, 4kHz -18dB
AGC Characteristics	<6dB Variation from 10uV to 10mV
Sensitivity	4uV (6dB (S+N)/N 30% mod @ 1KHz)
Spurious Response	10mV spurious signal produces no more output than a desired signal at 6dB (S+N)/N
Transmitter Power	16W @ 28V, 10W @ 14V (Typical)
Transmitter Duty Cycle	Recommended 10% maximum
Modulation Capability	70%
Carrier Noise Level	-39dB (S+N)/N
Frequency Stability	<2.5 ppm
Demodulation Audio Distortion	< 2% @ 70% modulation
Sidetone Fidelity	300-2500 Hz
Demodulation Audio Response	<6dB Variation from 300 to 2500 Hz

Table 23 VHF Communication Transceiver Specifications

1.5.2.5 Atlas ARS (Inertial Reference) Specifications

NOTE: Not an approved Attitude reference source. Attitude output intended for radar stabilization functions only (Not Currently Supported).

Attitude Static Accuracy	± 1.0 degree
Attitude Dynamic and Flight Accuracy	± 2.5 degrees
Slip output	Provided
Heading, Turn Rate, and Standard Turn Bank Angle Outputs	Not provided

Table 24 ARS Specification

1.5.2.6 Atlas installed weights in pounds

Unit	Unit Weight (lbs)	Installed Weight with Backshells (Less Wiring)
Atlas w/VHF	8.72 ±.25	9.82 ± .25
Atlas FMS Only	7.32 +/- .25	8.14 +/- .25

Table 25 Atlas Installed Weights

1.5.2.7 Atlas Navigation Specification

Glideslope Receiver	-
Selectivity	0 ± .0091 ddm w/ test signal varied ± 17kHz. 60dB for ± 132kHz offset
Sensitivity (flag)	10uV max
Spurious Response	< -60 dB
Centering Accuracy	0 ± 0.02 DDM or better
Deflection Response	67% of final value in 600msec
Localizer Receiver	-
Selectivity	6dB at least ±17kHz, 40dB no more than ±80kHz
Sensitivity (flag)	10uV max
Sensitivity (aural)	10uV max for 20dB (S+N)/N with 1kHz 30%mod
Centering Accuracy	+/-3mV
Deflection Response	67% of final value in 600msec
Audio Response	<6dB Variation from 350 to 2500 Hz, -20dB <150Hz >9kHz

Table 26 Atlas Navigation Specification

Avidyne Navigation Capabilities

Note 5

Note 3

Note 4

Note 2

Note 1

Spec	RNP 10	RNAV 5 GNSS	RNAV5 DME/DME	RNAV 5 VOR/DME	RNAV 2 GNSS (note 1)	RNAV 1 GNSS	RNP 4	RNP 1 GNSS	RNP APCH	RNP APCH w/ Baro VNAV	RNP AR APCH w/ RF (note3)	RNP AR APCH w/o RF (note3)
IFD4XX/5XX/Helios Navigation mode	Oceanic	Enroute			Enroute	Terminal	Oceanic	Terminal	Approach			
Procedure type	N/A	N/A			Arrivals, Departure	Arrivals, Departures, Approaches	N/A	Arrival, Departures, Approaches	LNAV, LNAV/VNAV LP, LPV			
ICAO Flight Plan Code	A1	B2	B3	B4	C2	D2	L1	O2	S1	S2	T1	T2
IFD4XX/5XX/Helios Capability	Yes	Yes	No	No	Yes	Yes	Yes	Yes	Yes (Note 5)	No	No	No

Note 1

RNAV1 requires total system error of not more than 1NM for 95% of the total flight time

Note 2

RNAV2 requires total system error of not more than 2NM for 95% of the total flight time

Note 3

GNSS sensor complies with AC 20-138. GNSS accuracy better than 36m 95%, SBAS GNSS accuracy is better than 2m 95%

Note 4

This table is intended to show certifications of avionics equipment. Capabilities shown do not constitute operational approval.

Note 5

LP and LPV guidance require SBAS, IFD4XX/5XX/Helios must be connected to an approved SBAS (e.g. WAAS) antenna.

Table 27 IFD4XX/5XX/Helios GPS Navigation Capabilities

1.6 Regulatory Compliance

1.6.1 Applicable TSOs

This section identifies Technical Standard Orders (TSOs) applicable to the IFD system. The conditions and tests required for TSO approval of this article are minimum performance standards. It is the responsibility of those installing this article either on or within a specific type or class of aircraft to determine that the aircraft installation conditions are within the TSO standards. TSO articles must have separate approvals for installation in aircraft. The article may be installed only if performed under 14 CFR Part 43 or the applicable airworthiness requirements.

TSO Number	Title	Type/Categories
TSO-C34e*	ILS Glide Slope Receiving Equipment Operating within the Radio Frequency Range of 328.6-335.4 Megahertz (MHz)	
TSO-C36e*	Airborne ILS Localizer Receiving Equipment Operating within the Radio Frequency Range of 108-112 Megahertz (MHz)	
TSO-C40c*	VOR Receiving Equipment Operating within the Radio Frequency Range of 108-117.95 Megahertz (MHz)	
TSO-C63d	Airborne Weather Radar Equipment	Class C (Display Functions Only)
TSO-C110a	Airborne Passive Thunderstorm Detection Equipment	
TSO-C112e	Air Traffic Control Radar Beacon System/Mode Select (ATCRBS/Mode S) Airborne Equipment	
TSO-C113a	Airborne Multipurpose Electronic Display	
TSO-C118a	Traffic Alert and Collision Avoidance System (TCAS) Airborne Equipment, TCAS I	
TSO-C128a*	Devices that Prevent Blocked Channels Used in Two-Way Radio Communications Due to Unintentional Transmissions	
TSO-C146d	Stand-Alone Airborne Navigation Equipment Using the Global Positioning System (GPS) Augmented by the Wide Area Augmentation System (WAAS). Airborne Supplemental Navigation Equipment Using the Global Positioning System (GPS) - Gamma 3	

TSO Number	Title	Type/Categories
TSO-C147a	Traffic Advisory System (TAS) Airborne Equipment	Class A (Display Functions Only)
TSO-C151d**	Terrain Awareness and Warning System (TAWS)	
TSO-C157c	Aircraft Flight Information Services – Broadcast (FIS-B) Datalink Systems and Equipment	
TSO-C165b	Electronic Map Display Equipment for Graphical Depiction of Aircraft Position	
TSO-C169a*	VHF Radio Communications Transceiver Equipment Operating Within The Radio Frequency Range 117.975 To 137.000 Megahertz	Class C, E, 3 and 5
TSO-C194	Helicopter Terrain Awareness and Warning System (HTAWS)	
TSO-C195b	Avionics Supporting Automatic Dependent Surveillance – Broadcast ADS-B Aircraft Surveillance Applications	
TSO-C201	Attitude and Heading Reference Systems AHRS	A4HXT7

*Not applicable for IFD510/545/410 or Atlas FMS Only units

** Only applies to 5xx/Atlas units. There are no annunciator outputs on 4xx units.

Table 28 IFD TSO Functions

1.6.2 TSO Deviations

TSO	Deviation(s)
TSO-C34e – ILS Glideslope Receiving Equipment	1. Environmental qualification performed in accordance with DO-160G rather than DO-160B.
TSO-C36e – Airborne ILS Localizer Receiving Equipment	1. Environmental qualification performed in accordance with DO-160G rather than DO-160B.
TSO-C40c – VOR Receiving Equipment	1. Environmental qualification performed in accordance with DO-160G rather than DO-160B.
TSO-C110a – Airborne Passive Thunderstorm Detection Equipment	1. Environmental qualification performed in accordance with DO-160G rather than DO-160B.
TSO-C113a – Airborne Multipurpose Electronic Display	1. The IFD display response time is not less than 1 second during Short-Time Operating Low Temperature environmental conditions as defined in Section 4.0 of RTCA/DO-160G.
TSO-C118a – Traffic Alert and Collision Avoidance System (TCAS) Airborne Equipment,	1. The IFD used the exceptions listed in appendix 1 of TSO-C147 in lieu of the corresponding minimum operational performance standards

TSO	Deviation(s)
TCAS I	specified in the TSO.
TSO-C128a - Equipment that Prevents Blocked Channels used in two-ways Radio Communications due to unintentional transmissions	1. Environmental qualification performed in accordance with DO-160G rather than DO-160B.
TSO-C146d - Stand-alone Airborne Navigation Equipment using the Global Position System augmented by the Satellite based Augmentation System	1. Environmental qualification performed in accordance with DO-160G rather than DO-160B.
TSO-C147a - Traffic Advisory System (TAS) Airborne Equipment	1. The IFD map does not place a range ring at 2 NM from the own aircraft symbol when a display range of 10 NM or less is selected;
TSO-C157c - Aircraft Flight Information Services - Broadcast (FIS-B) Data Link Systems and Equipment	1. Smoothing and scaling algorithms at high map ranges remove small patches of high-intensity NEXRAD returns in favor of surrounding lower-intensity returns.
TSO-C165b - Electronic Map Display Equipment for Graphical Depiction of Aircraft Position	1. De-cluttering on chart page not provided. 2. Location of traffic symbols in the absence of heading information
TSO-C169a - VHF Radio Communications Transceiver Equipment	1. Environmental qualification performed in accordance with DO-160G rather than DO-160B.
TSO-C201 - Attitude and Heading Reference Systems AHRS	1. The IFD system does not provide minor graduations at 5° intervals on the heading indicator

Table 29 IFD TSO Deviations

Table 29 above lists the TSO Deviations and a brief description of the nature of the deviation that have been granted for those applicable TSOs.

1.6.3 Non-TSO Functions

The following IFD functions are not TSO'd:

IFD Function
Display of Terrain Alerting
Display of Aircraft Checklists
Calculators (Air Data, Fuel Planner, etc)
Display of Timers and Schedulers
Display of RS-170 Video from an approved device
Synthetic Vision
Display of Navigation Charts
WiFi in and out
Bluetooth in
Auxiliary Radar Display (IFD4XX only)

Table 30 Non-TSO Functions

1.6.4 Partial TSO Functions

The following IFD TSOs are partial function:

TSO	Description	Comment
TSO-C110a	Airborne Passive Thunderstorm Detection Equipment	Display Only
TSO-C118a	Traffic Alert and Collision Avoidance System (TCAS) Airborne Equipment, TCAS I	Display Only
TSO-C147a	Traffic Advisory System (TAS) Airborne Equipment	Display Only
TSO-C157c	Aircraft Flight Information Services – Broadcast (FIS-B) Datalink Systems and Equipment	Display Only

Table 31 Partial Function TSOs

1.6.5 Open Problem Report

At the time of this revision, the IFD does not have any open problems that affect safety or design assurance level of the unit.

1.7 Software and Hardware Design Assurance Levels

The IFD contains software developed in accordance with DO-178B Level B, C, and D design assurance levels. The following table lists functions of the IFD system and their corresponding software design assurance level.

All complex electronic hardware devices were developed in compliance with DO-254 Level B.

Component	Function	DO-178B Design Assurance Level
IFD5XX IFD4XX ATLAS	Traffic	C
	Lightning	D
	Digital Moving Map (including Terrain and Synthetic Vision Display)	C
	Terrain Alerting	C
	Wx Datalink	D
	FMS	B (Precision Approach) C (All other Functions)
	VHF Communication (N/A for IFD510/545/410)	C
	VHF Navigation (N/A for IFD510/545/410)	B
	GPS Navigation	B
	Checklist	C
	Fuel Display	C
	Charts (N/A for 4xx models)	C
	Timers/Schedulers	C
	Calculators	C
Maintenance Mode	D	
Airborne Weather Radar	C	

Component	Function	DO-178B Design Assurance Level
	Display of External Video	C
	Data to ADS-B Out	C

Table 32 DO-178B Software Design Assurance Levels

1.8 Environmental Qualification Forms

The environmental Qualification for the IFD is listed in Appendix A: Environmental Qualification Form.

Note: If the IFD has been exposed to extreme cold temperature prior to start, it may take a warm up period to achieve standard performance.

1.9 Databases

The IFD utilizes several databases. All the databases can be loaded on the IFD using the USB port on the IFD. Reference the IFD5XX pn 600-00300-001, IFD4XX pn 600-00304-000 or Atlas Pilot’s Guide pn 600-00300-002 for updating the applicable IFD databases.

The operator is responsible to ensure that the navigation data used in the unit has the accuracy, resolution, and timeliness appropriate for the purpose of the flight operation being conducted. Using navigation data from an Avidyne authorized supplier will ensure that the navigation data has the same accuracy and resolution provided by official sources, in a format compatible with the intended function of the unit.

Avidyne accurately processes and validates the database data, but cannot guarantee the accuracy and completeness of the data provided by various state sources and their suppliers.

Provided databases have FAA DO-200A or DO-200B Type 2 Letter of Acceptance (LOA) for Obstacles, Nav Data, Terrain Data and Airport diagrams, in accordance with AC 20-153 for database integrity, quality, and database management practices for the navigation database. Charts database is vendor (Jepp) approved. Flight crew and operators can view the approval information at www.avidyne.com.

1.10 Electronic Map Display Information

This article meets the minimum requirements of TSO-C165b. Installation of this article requires separate approval i.e. TC, STC, field approval.

The maximum error for total system accuracy for the IFD map display, including latency is <15m*.

The moving map function of the IFD series products is intended as an aid to Pilot situational awareness and is not intended to be used as a navigation instrument.

* as defined in RTCA DO-257B

1.11 GPS Fault Detection and Exclusion (FDE)

FDE software is part of all IFD systems and does not require any installer or pilot action to operate. This FDE software is running at all times and if it detects an issue, it will alert the pilot through Caution-Alerting System (CAS) messages.

When the IFD is installed per the directions in this Installation Manual, it complies with the governing requirements for GPS Primary Means of Navigation in Oceanic and Remote Airspace (more than 200 nm from the nearest airport), when used with any commercially available RAIM/FDE Prediction Program. Examples of these prediction programs include the FAA's raimprediction.net, fltplan.com, www.sapt.faa.gov, and the Garmin FDE Prediction Program.

These programs only need to be run under the following scenarios for 14 CFR Parts 91, 121, 125, and 135 operations where the IFD is being used as the primary means of navigation and:

- TSO-C146d compliant antenna equipped aircraft that experience a WAAS failure or when operating outside of SBAS coverage areas;
- Non-TSO-C146d compliant antenna equipped aircraft (e.g. TSO-C129a only compliant systems) when operating in Oceanic and Remote airspace, Enroute and Terminal airspace, or during any LNAV/VNAV, LP, or LPV approach.

Prior to conducting Class II navigation (remote/oceanic), the owner/operator must obtain operational approval for using the IFD system for long-range navigation from the appropriate flight standards district office.

1.12 Terrain Alerting and Warning System

When the Terrain Awareness and Warning System (TAWS) option is enabled, the IFD provides a TSO-C151d compliant TAWS-B function. TAWS-B does not require any external equipment though an attached external annunciator panel will be driven by TAWS specific cautions and warnings¹. TAWS is always running in the background, and does not have a dedicated display page. TAWS-B contains the following sub-functions:

- **Premature Descent Alert (PDA)** – this function is designed to alert when the aircraft is hazardously below the normal approach path for the nearest runway at either the origin or destination airport
- **Excessive Rates of Descent (EDR)** – this function is designed to alert when the aircraft is experiencing excessive rates of descent given the current AGL altitude. The alert can be generated during any phase of flight
- **Negative Climb Rate (NCR) or Altitude Loss After Takeoff/Go-Around** – this function is designed to alert when the aircraft develops a negative climb rate immediately after takeoff or go-around or when an altitude loss is detected in that phase

¹ See Section 6.11.2

1.13 FIS-B ADS-B Weather Information

FIS-B uplink is an FAA approved source for METAR, TAF, WINDS, PIREPs, NEXRAD, AIRMET, SJGMET, and TFR information subject to the range limits for the broadcast of these products. FIS-B uplink is not an FAA approved source for NOTAMs.

This article meets the minimum requirements of TSO-C1 57c. Installation of this article requires separate approval i.e. TC, STC, field approval.

1.14 Part 23 STC Approved Model List

The aircraft listed on the Part 23 STC SA00343BO Approved Model List are eligible to install the IFD5XX/IFD4XX. However, the installer must determine if the installation is in compliance with the limitations stated in the STC and this manual. Any deviations from the STC and/or this manual must have a separate installation approval.

The installation of antennas on composite and/or pressurized aircraft requires engineering guidance beyond the scope of this manual. With respect to the Approved Model List STC, the physical mounting of the antenna is specifically excluded from the approval in the case of installation on the pressure vessel of a pressurized aircraft, composite aircraft, and aircraft with a certification basis of Amendment 23-45 or later, unless approved installation data is listed in the Master Document List of the STC. All early amendment, metal construction, non-pressurized aircraft may install the GPS antenna using this manual. The installation must be structurally sound and in accordance with FAA Advisory Circular 43.13-(). All other antennas must be installed using the antenna manufacturer's installation data or FAA Advisory Circular 43.13-().

1.15 Part 25 STC Approved Model List

The aircraft listed on the Part 25 STC ST00411BO Approved Model List are eligible to install the IFD5XX/Atlas in the aircraft listed in the STC Approved Model List. However, the installer must determine if the installation is in compliance with the limitations stated in the STC and this manual. Any deviations from the STC and/or this manual must have a separate installation approval.

The installation of antennas on composite and/or pressurized aircraft requires engineering guidance beyond the scope of this manual. With respect to the Approved Model List STC, the physical mounting of the antenna is specifically excluded from the approval in the case of installation on the pressure vessel of a pressurized aircraft or composite aircraft unless approved installation data is listed in the Master Document List of the STC. All metal construction non-pressurized aircraft may install the GPS antenna using this manual. The installation must be structurally sound. All other antennas must be installed using the antenna manufacturer's installation data. Aircraft weighing greater than 12,500lbs or pressurized shall refer to the aircraft Structural Repair Manual (SRM) for mechanical installations and SAE AS50881 for aircraft wiring requirements.

1.16 Avidyne Supplied Material

The following Ship Kits are available for ordering from Avidyne Corporation.

Note: Ship Kit content and/or Part numbers may change without notice, verify before ordering.

1.16.1 Product Ship Kits

Component	Ship Kit Black Bezel	Ship Kit Grey Bezel	Ship Kit Black Bezel With Video	Ship Kit Grey Bezel With Video
IFD540 Unit	850-00182-000 850-00182-700	850-00182-100 850-00182-800	850-00182-001 850-00182-701	850-00182-101 850-00182-801
IFD510 Unit	850-00182-010 850-00182-710	850-00182-110 850-00182-810	850-00182-011 850-00182-711	850-00182-111 850-00182-811
IFD545 Unit	850-00182-030 850-00182-730	850-00182-130 850-00182-830	850-00182-031 850-00182-731	850-00182-131 850-00182-831
IFD550 Unit	850-00182-020 850-00182-720	850-00182-120 850-00182-820	850-00182-021 850-00182-721	850-00182-121 850-00182-821

Table 33 IFD5XX Ship Kit

Component	Ship Kit Black Bezel	Ship Kit Grey Bezel
IFD440 Unit	850-00179-000 850-00179-700	850-00179-100 850-00179-800
IFD410 Unit	850-00179-010 850-00179-710	850-00179-110 850-00179-810

Table 34 IFD4XX Ship Kit

Component	Ship Kit Black Bezel	Ship Kit Grey Bezel	Ship Kit Black Bezel With Video	Ship Kit Grey Bezel With Video
Atlas unit	850-00194-020	850-00194-120	850-00194-021	850-00194-121
Atlas FMS Only Unit	850-00194-030	850-00194-130	850-00194-031	850-00194-131

Table 35 Atlas Ship Kit

1.16.2 Optional Ship Kits

Component	Fixed Wing Aircraft Ship Kits
IFD5XX Tray	850-00188-000
IFD5XX Install kit (no tray)	820-00113-000
IFD5XX Tray and Install Kit IFD5XX	850-00188-002

Table 36 IFD5XX Optional Ship Kits

Component	Fixed Wing Aircraft Ship Kits
IFD4XX Tray	850-00184-000
IFD4XX Install kit (no tray)	820-00114-000
IFD4XX Tray and Install Kit	850-00184-002

Table 37 IFD4XX Optional Ship Kits

Component	Fixed Wing Aircraft Ship Kits
Atlas Install Kit	820-00128-000

Table 38 Atlas Optional Ship Kits

Component	Ship Kit 850-00217-001
GPS Antenna	200-00282-000

Table 39 GPS Antenna Kit

Component	Ship Kit 820-00101-001
ByteFlight Cable, 20 ft.	033-00102-000

Table 40 ByteFlight Ship Kit

1.17 Materials Required but not Supplied

The IFD will require common installation supplies. The following items may be required for installation, but not supplied:

- Wire (Shielded and Un-shielded)
- Hardware (Screws, washers, nuts, ring terminals, etc)
- Circuit Breakers
- Tie wrap or Lacing Cord
- Coaxial Cables
- Wire Splices
- Solder Sleeves
- Antenna(s)
- Diplexers

2. Installation Considerations

The following section will describe installation instructions for the IFD 4XX/IFD5XX/Atlas GPS/NAV/COM Unit. The installer must use instructions in Section 3 in order to verify that an IFD or Atlas system can be installed the subject aircraft. The IFD should be installed using information contained in this manual, other approved installation data such as TC or STC data, standard industry practice while following guidance in FAA AC 43.13-(), AC 20-138 (), and AC 20-67() (see Sec. 2.4)Minimum System Configuration

The IFD can be installed in one of two operational configurations:

2.1.1 VFR Installation

This section is intended for stand-alone IFD/Atlas installations intended for VFR navigation. All VFR installations, as described in this Section, are considered a minor alteration when installed on a no-hazard basis to supplement VFR navigation.

The following items must be installed in IFD VFR Configuration:

- 1ea. IFD5XX or IFD4XX or Atlas unit
- 1ea. GPS Antenna (TSO-C144a or TSO-C190, reference Section 3.3.5 for approved antennas)
- 1ea. VHF Communication Antenna is needed for communication functions (N/A for IFD510/545/410)
- 1ea. VHF Navigation Antenna is needed for VOR functions (N/A for IFD510/545/410)

All VFR installations must install a “GPS APPROVED FOR VFR USE ONLY” placard.

All VFR installations, as described in this Section, are considered a minor alteration when installed on a no-hazard basis to supplement VFR navigation.

2.1.2 IFR Installation

2.1.2.1 Aircraft Categories

This installation manual provides guidance for the installation of IFD4XX/IFD5XX/Atlas GPS/Nav/Com units in airplanes certified under CFR14 Part 23 and Part 25. Part 23 aircraft are divided into classes based on weight and powerplant. These classes have specific installation requirements for IFD operations.

- Part 23, Class I
Single reciprocating-engine (SRE) under 6,000lbs. Class I airplanes may install a single IFD4XX/IFD5XX for IFR operations.
- Part 23, Class II
Multi reciprocating-engine (MRE) and single turbine-engine (STE) under 6,000lbs. ClassII airplanes require dual IFD4XX/IFD5XX/Atlas or a single IFD and a second navigation or communication radio for IFR operations.
- Part 23, Class III
Single reciprocating-engine (SRE), single turbine-engine (STE), multi reciprocating-engine (MRE) and multi turbine-engine (MTE) equal to or over 6,000lbs. Class III

airplanes require dual IFD4XX/IFD5XX/Atlas or a single IFD and a second navigation or communication radio for IFR operations.

- Part 23, Class IV (Commuter Category)
Turbojet powered or airplanes equal to or over 12,500lbs but less than 19,000 lbs and 19 seats. Class IV airplanes require dual IFD4XX/IFD5XX/Atlas or a single IFD and a second navigation or communication radio for IFR operations. Aircraft using GPS Oceanic/Remote navigation must have a second navigation receiver installed in the aircraft that must be a FAA TSO'd unit.
- Part 25
Turbojet powered aircraft or aircraft weighing more than 19,000 lbs or seating more than 19 passengers. Part 25 airplanes dual installations containing IFD4XX, IFD5XX or Atlas systems for IFR operations. System safety analysis for the specific airplane type must be considered and a third independent type navigation or communication radio may be required. Aircraft using GPS Oceanic/Remote navigation must have a second navigation receiver installed in the aircraft that must be a FAA TSO'd unit.

2.1.2.2 IFD/Atlas Equipment

This section is intended for IFR installations. The following items must be installed in IFD IFR Configuration:

- IFD5XX, IFD4XX or Atlas unit(s). See Section 2.1.2.1;
- GPS Antenna (TSO-C190 or approved antennas listed in Section 3.3.5)
- VHF Communication Antenna is needed for communication functions; (N/A for IFD510/545/410)
- Navigation Antenna(s) is needed for VOR/LOC/GS functions; (N/A for IFD510/545/410)
- Remote Annunciator is required if the IFD is not in the field of view of the pilot, reference Section 5.1.2;
- IFD should be interfaced to an Airdata source for automatic altitude leg sequencing (optional). If no baro-altitude data is supplied, altitude leg types must be manually sequenced for IFD5XX/IFD4XX/Atlas.
- The IFD must be connected to the primary navigation instrument (CDI/HSI/EHSI) indicator. The primary navigation instrument must have a Vertical Deviation Indicator.
- Second navigation receiver or communication transceiver must be installed on Part 23, Class II, Class III and Class IV airplanes (see section 2.1.2.1 above).
- Aircraft using GPS Oceanic/Remote navigation must have a second navigation receiver installed in the aircraft. In these cases, the second navigation receiver or communication transceiver must be a FAA TSO'd unit.
- Separately approved Marker Beacon System.

Figure 1 shows an IFR installation. IFR installation must be installed as major alteration to the aircraft.

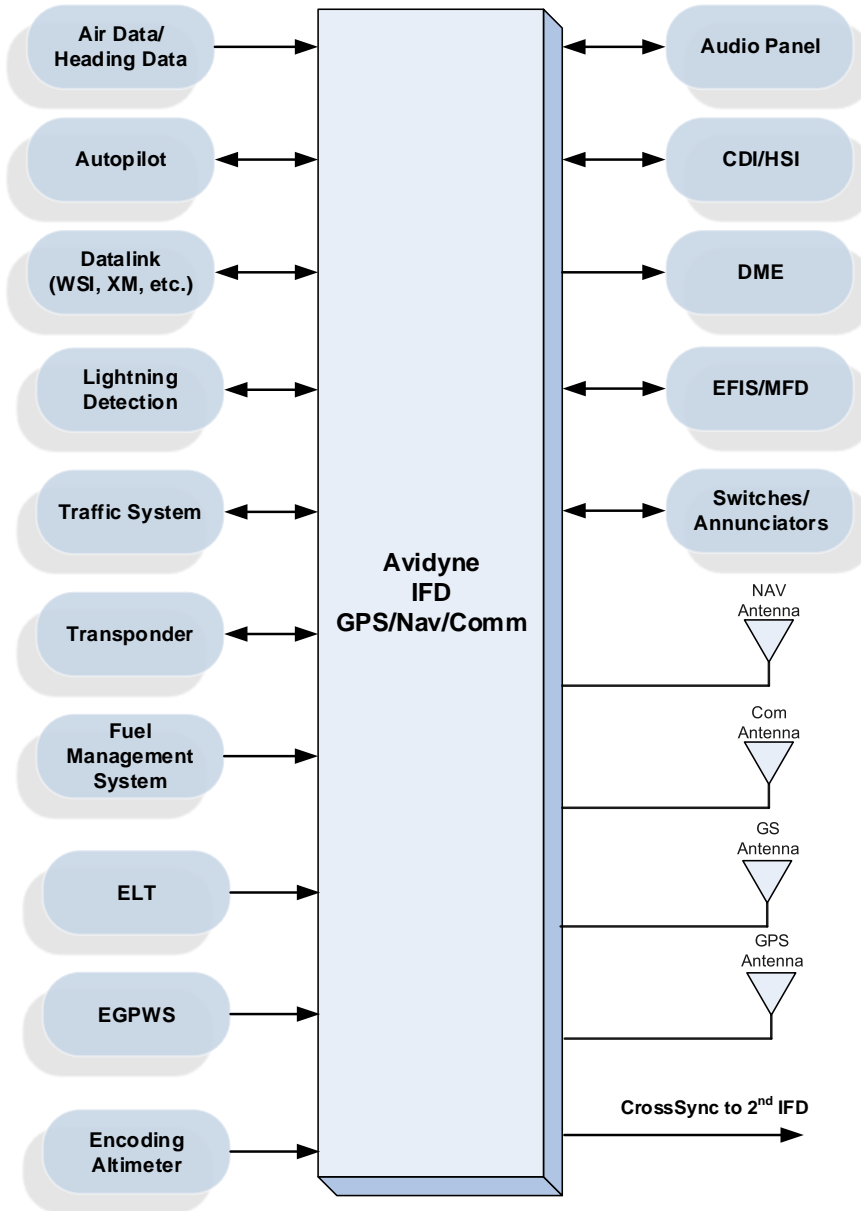

Figure 1 Full IFR Installation (IFD)

2.1.2.3 Approved IFR Operations

If the IFD is installed per this section, it can provide guidance for the following operations conducted under instrument flight rules (IFR):

- VOR, LOC, ILS instrument approach procedures (procedures using VHF radio guidance)
- RNP instrument approach procedures using the following lines of minima:
 - LNAV minima (including when using advisory vertical guidance from the system).
 - LNAV/VNAV minima.
 - LPV minima; and
 - LP minima.

2.1.2.4 GPS Oceanic / Remote Navigation

All aircraft approved for GPS Oceanic/Remote navigation must have dual electrical power/ground connections to both IFD units as shown in Section 4.9 and described in FAA AC 20-138() Appendix 1.

Note: All equipment required by 14 CFR 91.205 must be previously installed on the aircraft for IFR operations.

Note: The IFD545, IFD550 and ATLAS cannot be used as a required attitude indicator. Attitude information that can be displayed on these units may only be used as a **secondary (non -required)** source of attitude information.

Note: It is imperative that only one source of terrain cautions, and warnings be enabled on the airplane so as to avoid the potential for conflicting information to be presented to the pilot. If a TAWS system is installed but the IFD's internal TA and FLTA functions are to be used for terrain avoidance, the TAWS system *must* be fully disabled. If a separate TAWS system is to be used the caution and warning indications generated by the TAWS system can be displayed on a remote third-party annunciator and the IFD's TA and FLTA displays, and audio must be inhibited. See section 7.5.4.

Note: The IFD system supports a Honeywell KGP560/860 system with a remote third-party annunciator only. All other external TAWS/EGPWS systems must be disabled if the internal TA and FLTA are to be operational on the IFD system.

2.2 Garmin GNS Replacement Considerations

The IFD5XX/4XX is designed to be a slide-in replacement for a GNS-530/W or GNS-430/W. For those replacement installations, the existing aircraft tray and wiring may be reused. However, some changes may be required as indicated below and described in this manual.

2.2.1 Circuit Breakers

Some aircraft may be required to replace the installed circuit breaker and power and ground wiring to accommodate the IFD5XX/4XX/Atlas.

2.2.2 WAAS Enabled:

If the unit being replaced was a WAAS-enabled device, then the WAAS antennas previously installed can be reused.

2.2.3 TAWS:

If the existing TAWS is to remain with the aircraft the IFD-5XX/4XX/Atlas shall not be used to augment this information to the flight deck without additional approval.

The IFD5XX/4XX/Atlas unit is approved for TSO-C151d for TAWS -B operations with an additional paid option unlock. If the IFD is replacing existing TAWS-B avionics, wiring changes may be required.

2.2.4 TAWS Audio:

If the unit being replaced was not a TAWS-enabled device, or if the TAWS Audio output signals were not already connected to the aircraft audio panel(s), some additional wiring will be required from the IFD5XX/4XX/Atlas tray to the aircraft audio panel(s) as identified in Section 6.11.1 in order to supply IFD5XX/4XX/Atlas terrain alerting audio (Forward Looking Terrain Alerting FLTA functionality) and TOD chime to the headsets.

If the paid TSO'd TAWS unlock option is enabled, this additional wiring is required as part of the TAWS activation.

2.2.5 Installation with Avidyne AXP340/322 Transponder:

For those installations that use a combined IFD5XX/4XX/Atlas - Avidyne AXP340/AXP322 Mode S ADS-B transponder, the on-ground/in-air discrete signal wire may need to be added from the IFD5XX/4XX/Atlas tray to the AXP340/322 tray as identified in Section 6.12.

Note: Installations replacing an existing non-WAAS GPS/NAV/COM transceiver can upgrade to a WAAS installation using section 3 of this manual.

Note: Installations replacing a GNS-530/W or GNS-430/W must verify the aircraft is on the IFD5XX/4XX Approved Model List, Avidyne Document Number AVIFD-318 (Part 23) or AVIFD-583 (Part 25).

Note: The IFD system supports a Honeywell KGP560/860 system with a remote third-party annunciator only. All other external TAWS/EGPWS systems must be disabled if the internal TA and FLTA are to be operational on the IFD system.

2.2.6 Additional Installation Data Sources

This installation manual (Avidyne document 600-00299-000) does not constitute complete FAA approved data to install Avidyne IFD4XX/IFD5XX/Atlas units in subject aircraft unless this manual is specifically identified as approved data by FAA approved installation approval i.e., STC, approved installation document or drawing.

Avidyne AML STC SA00343BO-A for Part 23 Airplanes identifies this installation manual as approved data for airplanes listed on the Approved Model List for that STC.

The following are sources to that may be used to develop FAA approved data for IFD4XX/IFD5XX/Atlas installations. Other approved data acceptable to the administrator may be used.

600-00299-000	This manual.	SA00343BO-A for Part 23 Airplanes. Approved data for aircraft listed on AML Reference data for all other installaltions
AVIFD-318	Part 23 Approved Model List	
AVIFD-583	Part 25 Approved Model List	
AC43.13-1B Change 1		“For the inspection and repair of non-pressurized areas of civil aircraft, only when there are no manufacturer repair or maintenance instructions.”
AC43.13-2B		“For the inspection and alteration on non-pressurized areas of civil aircraft of 12,500lbs gross weight or less.”
Aircraft Maintenance Manual		
Aircraft Structural Repair Manual (SRM)		
Aircraft Structural Repair Manual (SRM)		
Aircraft Prints / Wiring Diagrams		The existing aircraft wiring prints provide support information required to integrate the IFD4xx/5xx to the aircraft’s systems.
Installer developed data		DER 8110-3 Engineering Approval.
SAE AS50881	Wiring Aerospace Vehicles	

2.2.7 Electrical Load Analysis (ELA)

An ELA must be accomplished to determine that the electrical limits of the specific aircraft are not exceeded.

2.3 Optional Installation Features

This section summarizes interfaces to avionics and optional features that may require extra wiring.

Feature	Description	Reference Section for Installation Details
Audio Panel Aural	Allows IFD produced aural alerts (e.g., FLTA terrain alerts, Top of Descent alerts, 500' callouts, etc) to be heard in the headsets.	Section 6.11.1
Transponder Support	Allows IFD GPS position transmission to the transponder for ADS-B operation and IFD Air/Ground output to the transponder for automatic Ground-Alt transition.	Section 6.12
Video In	Allows input from any RS-170 format video.	Section 6.16
Radar display and control	Allows display of digital radar display. The IFD5XX /ATLAS can control the radar as a standalone display.	Section 6.17 Requires Ship Kit (Field load) 500-00232-001 or activation coupon 500-00232-002**
Com Presets, Forward*	Enables external command (e.g., yoke-mounted button) to select frequencies forward in the com preset list to be loaded into the #1 Standby com slots.	Section 6.1.12.4
Com Presets Reverse *	Enables external command (e.g., yoke-mounted button) to reverse selected frequencies in the com preset list to be loaded into the #1 Standby com slots.	Section 6.1.12.4
Com Frequency Active-Standby Swap*	Enables external command (e.g., yoke-mounted button) to swap the Active and #1 Standby com frequencies.	Section 6.1.12.4
Nav Frequency Active-Standby Swap *	Enables external command (e.g., yoke-mounted button) to swap the Active and #1 Standby nav frequencies.	Section 6.1.12.4
Synchro Heading Input *	Allows the IFD to take heading data in via synchro protocol.	Section 6.1.6
Standby Com Monitor*	Allows the com frequency in the #1 standby slot to be heard in the headsets when installed with a compatible audio panel (e.g., Avidyne AMX240).	Section 6.1.12.5
16 watt transmitter activation 28volt installations only*	Allows the com to transmit at 16 watts	Requires Ship Kit (Field load) 500-00210-001 or activation coupon 500-00210-002. **
WiFi/Bluetooth	Allows the connection of portable electronic equipment to the IFD.	Installed at the factory
IFD5XX GLAS Enablement	Adds LPV approach functionality	Requires Ship Kit (Field Load) 500-00277-001 or activation coupon 500-00277-002**
TAWs	Enables TAWs	Requires Ship Kit (Field load) 500-00236-001 or activation coupon 500-00236-002. **

*N/A for IFD510/545/410 and Atlas FMS Only units

** Refer to Avidyne service bulletin 601-00182-035 "Paid Option Upgrade" procedure available on the Avidyne dealer website.

Table 41 Optional Installation Features

2.4 IFD Interfaces

The IFD can interface with a host of other avionics equipment. The following list represents the proven interfaces. There may be other devices that can be configured the same as one on the below list, but Avidyne has not tested it and can therefore not make any compatibility claims.

Category	Vendor	Model
Air Data	B&D	2600 ADC
	B&D	2601 ADC
	B&D	2800 ADC
	B&D	900004-003 ADC
	Bendix King	KAD 280/480 ADC (KDC 281, 481)
	Shadin	8800T Alt Computer
	Shadin	9000T Alt Computer
	Shadin	9200T Alt Computer
	Shadin	9628XX-X Fuel/ Air Data Computer
	Insight	TAS 1000 ADC
	Icarus	Instrument 3000
	Sandia	SAC7-35
	Garmin	GDC74A
Encoding Altimeter or Blind Encoders	Bendix King	KEA-130A
	Bendix King	KEA-346
	Terra	AT-3000
	Sandia	SAE5-35
	Trans-Cal Industries	IA-RS232-X
	Trans-Cal Industries	SSD120
	ACK Technologies	A-30
EADI	Honeywell	ED-600
EFIS	Bendix King	EFS 40/50
	Avidyne	EXP5000
	Aspen	Pilot PFD (EFD1000)
	Collins	Proline 21
	Collins	EFIS 84

Category	Vendor	Model
	Honeywell	EDZ-605
	Honeywell	Primus 1000
	Sextant	SMD 45
	Garmin	G500/600/TXi
	Garmin	G5
	Garmin	GI-275
Displays	Garmin	MX20
	Garmin	GMX200
	Garmin	GPSMAP 195
	Garmin	GPSMAP 295
	Garmin	GPS III Pilot
	Garmin	GPSMAP 196
	Garmin	GPSMAP 296
	Garmin	GPSMAP 396
	Garmin	GPSMAP 496
	Garmin	GPSMAP 695
	Garmin	GPSMAP 696
	Garmin	Aera 796/795
	Argus	3000
	Argus	5000
	Argus	7000
	Horizon	DDMP
	Avidyne	EX500
	Avidyne	EX600
	Avidyne	EX5000
	Avidyne	FlightMax Series
Heading	Bendix King	KAH 460 Inertial System (KAU 461 also)
	Collins	AHC 85 Inertial System Laseref
	Honeywell	HG 1075AB, HG 1095AG Inertial Systems
	Litef	LTR 81 Inertial System
	Litton	LTN 90-100 Inertial System
	Litton	LTN 91 Inertial System
	Litton	LTN 92 Inertial System

Category	Vendor	Model	
EHSI	Sandel	SN3308	
	Sandel	SN3500	
	Honeywell	ED-600	
Fuel	Shadin	91053XP and 91053XT-D "Digiflo-L" Digital Fuel Mgmt Systems	
	Shadin	91204XT(38)D and 91204XT-D "Miniflo-L" Digital Fuel Mgmt Systems	
	Shadin	91802-() "DigiData" Fuel/ Airdata	
	JPI	EDM-700 Engine Monitor	
	JPI	EDM-760 Engine Monitor	
	JPI	FS-450	
	ARNAV	FC-10	
	ARNAV	FT-10	
	EI	FP-5L	
	EI	CGR-30P	
Traffic	Insight	GEM 3	
	L3	SKY497 SkyWatch	
	L3	SKY899 SkyWatchHP	
	Bendix King	KTA-870	
	Bendix King	KTA-970	
	Bendix King	KMH980	
	Bendix King	KMH880	
	Garmin	GTS800/820/850	
	Ryan	TCAD 9900B	
	Ryan	TCAD 9900BX	
	Avidyne	TAS-6XXA series	
	Transponder	Garmin	GTX330 (transponder functionality only)
		Garmin	GTX330 ES *
Garmin		GTX 330D ES *	
Garmin		GTX335 *	
Garmin		GTX 345 *	
Garmin		GTX 327	

Category	Vendor	Model
	Garmin	GTX3000
	Honeywell Bendix/King	KT74
	Honeywell Bendix/King	MST70B
	ACSS	NXT-700
	L-3	NGT9000 Series
	Trig	TT31/22
	Rockwell Collins	TDR94/TDR94D
	Avidyne	AXP340/322
	Bendix King	KXP80
	Becker	BXT65XX
Lightning	L3	WX500
	Avidyne	TWX670 ("Native" format)
Datalink	Garmin	GDL-69/69A***
	Avidyne	MLB100
	WSI (No Longer Supported)	AV-300/350
	Heads-up Technologies	XMD076
Autopilot	Avidyne	DFC90
	Bendix King	KFC400
	Bendix King	KCP320
	Bendix King	KFC325
	Bendix King	KFC300
	Bendix King	KFC225
	Bendix King	KFC200
	Bendix King	KFC250
	Bendix King	KFC275
	Bendix King	KFC150
	Bendix King	KAP150
	Bendix King	KAP140
	Bendix King	KAP100
	Century	I
	Century	II
	Century	III
	Century	IV

Category	Vendor	Model
	Century	21
	Century	31/41
	Century	2000
	Century	Triden
	Century	AK 1081 GPSS Converter
	Collins	APC-65 Series
	Collins	FGC-65
	Collins	FYD-65
	STec	20
	STec	30
	STec	40
	STec	50
	STec	55
	STec	55X
	STec	60 PSS
	STec	60-1
	STec	60-2
	STec	65
	STec	ST901 GPSS Converter
Miscellaneous	Garmin	GAD42 Interface Adapter
EGPWS	Bendix King	MK V, MK VII, MKV-A, MK VI, MK VIII, MK XXII, MK XXI, KGP560, KGP860
DME	Bendix King	KN 61
	Bendix King	KN 62/62A
	Bendix King	KN 63
	Bendix King	KN 64
	Bendix King	KN65
	Bendix King	KDI 572
	Bendix King	KDI 574
	Bendix King	KDM706
	Collins	DME 40
	Collins	DME 42
	Collins	TCR 451
	Narco	DME 890

Category	Vendor	Model
	Narco	IDME 891
	ARC (Cessna)	RTA-476A
Nav Indicator	Garmin	GI 102/A
	Garmin	GI 106/A
	Bendix King	KI 202
	Bendix King	KI 203
	Bendix King	KI 204
	Bendix King	KI 206
	Bendix King	KI 208
	Bendix King	KI 208A
	Bendix King	KI 209
	Bendix King	KI 209A
	Bendix King	KI 525A
	Bendix King	KPI 552/B
	Bendix King	KPI 553/A/B
	Century	NSD 360A
	Century	NSD 1000
	Collins	331A-6P
	Collins	331A-9G
	Collins	PN-101
	Mid Continent	MD 222-402/-406
	Mid Continent	MD 200-20X/-30X
	STec	ST 180
	Sperry	RD444
	Sperry	RD 550A
	Sperry	RD 650
RMI	Bendix King	KI 229
	Bendix King	KNI 582
	Bendix King	KDA 692
External GPS Annunciator	Mid Continent	MD41-Series
	Staco Switch	992561
	Vivisun	95-40-()
	Vivisun	95-45-()
Remote TAWS Annunciator	Garmin	013-0079-XX

Category	Vendor	Model
	Mid Continent	MD41-10XX
Audio Panel	Avidyne	AMX240
	Apollo (Garmin)	SL10
	Apollo (Garmin)	SL15
	Garmin	GMA 340
	Garmin	GMA 347
	PS Engineering	6000
	PS Engineering	7000
	PS Engineering	8000/8000BT
	Bendix King	KMA 24/24H
	Bendix King	KMA 26
406 ELT	Bendix King	KMA 28
	Artex	ME406
	Ameri-King	AD 451-()
	Ack	E-04
	Narco	Not specified
	Pointer	3000
	Kannad	Not specified
Radar	Bendix King	RDR 2000 *
	Bendix/King	RDR 2100 **** RDR2060 ****
	Bendix/King	RDS-8X *****
UAT	Avidyne	Skytrax100 (formerly MLB100)
	Avidyne	SkyTrax100B* / SkyTrax200
	Freeflight Systems	FDL-978-RX**
	Garmin	GDL 88**

*IFD Software version 10.2 or higher

**IFD Software version 10.2.1 or higher

*** Compatibility with P/N 011-00986-00 or 011-00987-00 only pre software 10.2.3.1. With software 10.2.3.1 or higher P/N 011-03177-X0 will function

**** IFD Software version 10.2.4.1 or higher

***** IFD Software version 10.3.0.2 or higher

Table 42 IFD5XX/IFD4XX/ATLAS Compatible Equipment

2.5 Pre-Installation Checklist

Prior to beginning installation of the IFD5XX/IFD4XX/ATLAS, complete the following pre-installation checklist. This checklist will help in determining installation requirements. If the Installation Items below are not complete, additional installation approval may be required.

Installation Item	Reference	IFDXXX	ATLAS	Complete
Is the aircraft on the Avidyne STC Approved Model List?	Avidyne Documents AVIFD-318 or AVIFD-583	✓	✓	<input type="checkbox"/>
Is IFD replacing an existing GPS/NAV/COM or TAWS system used for Part 91/135 TAWS compliance?	If yes, TAWS enablement is required	✓	✓	<input type="checkbox"/>
Can the IFD5XX/IFD4XX tray be installed per the data in this manual?	If No, additional installation approval is required.	✓	N/A	<input type="checkbox"/>
Navigation(s) Antenna Installed (N/A for IFD510/545/410)	Section 3.5	✓	✓	<input type="checkbox"/>
Communication Antenna Installed (N/A for IFD510/545/410)	Section 3.4	✓	✓	<input type="checkbox"/>
Is the IFD, or remote annunciator lights, installed within the Pilot's Field of View?	Section 5.1 or 5.2	✓	✓	<input type="checkbox"/>
Does the aircraft have an approved GPS antenna installed on the aircraft? Or, can the GPS antenna be installed per this manual?	Section 3.3.5	✓	✓	<input type="checkbox"/>
Does the aircraft have a previously approved Marker Beacon System installed in the aircraft? (Not needed for VFR installations)	Section 2.1.2.2	✓	✓	<input type="checkbox"/>
Does the aircraft have a second NAV or COMM installed? Not needed for VFR Installations.	Section 2.1.2.2	✓	✓	<input type="checkbox"/>
Does the aircraft have a sufficient electrical power for the IFD installation?	Section 1.5	✓	✓	<input type="checkbox"/>
Does the installation location comply with the Environmental Testing of the IFD unit?	Appendix A: Environmental Qualification Form	✓	✓	<input type="checkbox"/>
Does the Airplane Flight Manual Supplement adequately cover the installation?	If no, additional installation approval is required. (Reference: Avidyne Document 600-00298-XXX, or 600-00346-000)	✓	✓	<input type="checkbox"/>

Table 43 Pre-Installation Checklist

3. Antenna Installation

This section describes the installation of the GPS, NAV, and Glideslope antennas on unpressurized, metallic fuselage airplanes. The installer is responsible to ensure the structural aspects of the installation meet all regulatory requirements and are adequate for the aircraft type. Antenna installations on airplanes with composite or pressurized fuselages, and aircraft with certification basis of Amendment 23-45 or later, are beyond the scope of this manual and a separate installation approval is required.

3.1 Antenna Bonding

All antennas should be well bonded to the aircraft. Reference AC 43.13-2b paragraph 307 for additional information.

3.2 Antenna Environmental Qualifications

Verify the antenna is appropriately qualified to be installed on the aircraft. Reference the antenna manufacturer's RTCA DO-160(x) qualification form.

3.3 GPS Antenna

The GPS Antenna should be installed using practices acceptable to the antenna and aircraft manufacturers. Regulatory guidance for antenna installations can be found in AC 20-138() Chapter 12, AC 43.13-2B Chapter 3, and AC 43.13-1B Chapter 4. Also reference Appendix C in this manual.

The GPS antenna listed in Table 39 can be installed on unpressurized metal airplanes with a certification basis of Amendment 23-43, or earlier, using the data below. All other GPS Antenna installations are beyond the scope of this manual and a separate installation approval is required.

The Avidyne GPS antenna, Avidyne Part Number 200-00282-000, can be installed as shown in Figure C - 6 through Figure C - 10. The GPS Antenna must be installed using the following guidelines to be in compliance with the STC.

GPS Antenna Location:

- Fuselage skin must be 2024-T3 aluminum (or equivalent)
- Fuselage skin thicknesses beyond the range provided in Table 44 below are outside the scope of this installation
- Selected antenna location may not be within one full bay of other cutouts, skin joints, or load introduction points
- Doubler installation on, or adjacent to, primary or fatigue critical structure, as defined by the aircraft manufacturer or regulatory guidance, requires separate approval
- Evaluate the installation per AC43.13-2B, Chapter 3, paragraph 303(b) for gaps due to fuselage curvature. If a saddle is required, fabrication should be per AC 43.13-1B, and should completely fill the curvature gaps, and should not be riveted to the fuselage skin. The only purpose of the saddle is to act as a tapered shim and is not intended to transfer load into the skin

Doubler Fabrication:

- Doubler material is to be 2024-T3 clad aluminum per AMS QQ-A-250/5
- Form the doubler to match the fuselage curvature
- Etch, alodine, and prime the doubler per the guidance provided in AC43.13-1B
- Drill holes and install rivets per AC43.13-1B
 - It is acceptable to slightly vary the rivet and row spacing to accommodate existing frames and stringers provided 2D edge distance and 4D minimum rivet spacing is maintained and no rivet is installed within 0.75" of the antenna mounting holes
 - Rivet type is dependent on the type of rivets in the adjacent fuselage structure. If the adjacent rivets in the structure around the bay selected for the doubler installation are protruding head type, install MS20470AD rivets in the outer row of the doubler. If the adjacent rivets are countersunk or dimpled, install either MS20426AD or NAS1097AD rivets per the table below. Reference Table 148 for rivet type and doubler thickness appropriate for the aircraft's skin thickness.

Fuselage Thickness	Doubler Thickness	Doubler Drawing
0.016-0.025"	0.020"	See Figure C - 9 in Appendix C.
0.032-0.050	0.032"	

Table 44 Doubler Thickness

3.3.1 GPS Antenna Location

The following recommendations should be followed when choosing an installation location for the GPS antenna. Prior to installing the GPS antenna, it is recommended to temporarily mount the GPS antenna in the desired location and functional ground test the GPS system.

- The antenna must be mounted on the exterior upper fuselage of the aircraft
- The GPS antenna should be mounted more than 2 feet from any transmitting antenna.
- The GPS antenna should be mounted in a location that minimizes the effects of shadowing by the aircraft structure.
- The GPS antenna should be installed more than 6 inches from any other antenna, including another GPS antenna.
- The GPS antenna should be installed in a location that allows the antenna to be level in normal cruise flight.

- For multiple GPS installations, the antennas should not be mounted in a straight line from front to rear of the aircraft along the longitudinal axis on the aircraft to prevent simultaneous antenna damage from lightning strikes.
- Antennas should be installed 3" or more from the windshield.

3.3.1.1 Aircraft Lightning Zone Approved Locations

If installing an Avidyne GPS Antenna (Avidyne Part Number 200-00282-000), the GPS antenna is qualified to be installed in aircraft lightning zone 2A as defined by SAE ARP5414A and RTCA DO-160G.

Procedure:

1. Determine the keep out areas, zone 1A and 1B
2. No Installation Areas of Zone 1A and 1B and for these aircraft are 1.3 meters each.
3. Measure 2.6 meters from the aircraft nose to begin zone 2A on the aircraft.

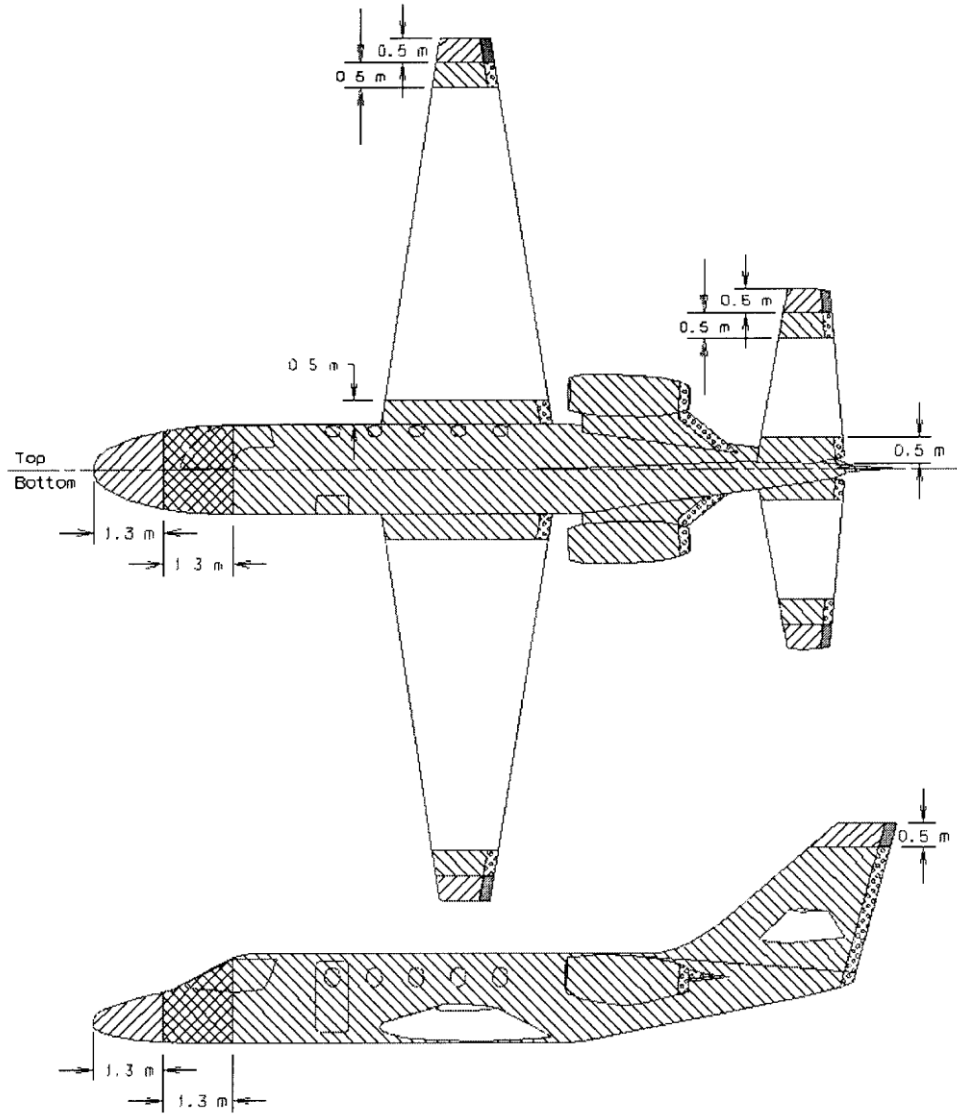

Legend

Zone 1A		Zone 2A	
Zone 1B		Zone 2B	
Zone 1C		Zone 3	

Figure 2 Large Aircraft Lightning Zone Map

Note: Locating the GPS antenna in the correct aircraft lightning zone is the responsibility of the installing agency. If a System Equipment DER is necessary, the Aircraft Electronics Association is a good source of information. The telephone number is +1 (816) 347-8400.

If installing an Avidyne GPS Antenna (Avidyne Part Number 200-00282-000), the GPS antenna is qualified to be installed in aircraft lightning zone 2A as defined by SAE ARP5414A and RTCA DO-160G. The *No Installation Area* can be determined using Figure 3. The distance found by using Figure 3 defines a zone immediately aft of the nose of the aircraft, or propeller in the case of single engine propeller driven aircraft, where the GPS antenna should not be installed. Aircraft locations aft of the *No Installation Area* are acceptable to install the GPS antenna. Figure 4 below shows an example of the *No Installation Area*.

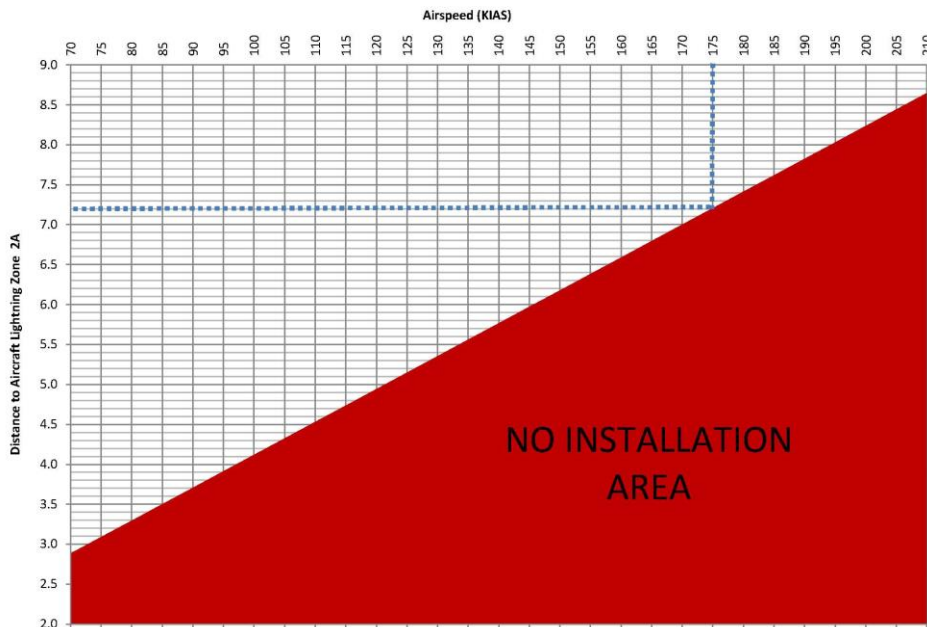

Figure 3 Distance to Aircraft Lightning Zone 2A

Procedure:

4. Determine the Maximum Cruising Speed (V_{no}) for the aircraft. **Note:** Indicated Airspeed in knots (KIAS) must be used in the table.
5. Locate the Airspeed for the aircraft on the Horizontal Axis of the table. Draw a vertical line from the Airspeed to the No Installation Area.
6. Draw a horizontal line from the No Installation Area, found in Step 2, to the Vertical Axis on the chart.
7. Determine the Distance (in feet) to Aircraft Lightning Zone 2A for the aircraft on the Vertical Axis.

Example:

For example, if an aircraft shown in Figure 4 has a V_{no} of 175 KIAS, the No Installation Area will be 7.2 feet. This is shown on Figure 3 with a dotted line and Figure 4 with a shaded area.

Aircraft with a V_{no} greater than 210 KIAS may install the GPS antenna 8.6 feet aft of the nose of the aircraft (excluding propeller).

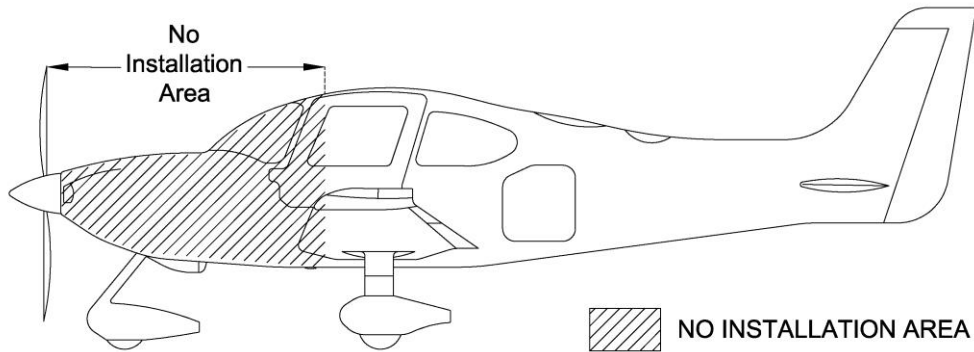

Figure 4 Small Aircraft No-Installation Area

3.3.2 GPS Antenna Bonding

The GPS Antenna should have ≤ 2.5 milliohm resistance to the aircraft fuselage.

3.3.3 GPS Antenna Cable

The GPS Antenna Cable must be RG-142B, RG-400, or an equivalent 50Ω double shielded coaxial cable. The GPS antenna cable loss should not be greater than 6.5dB or less than 1.5 dB. Each connector on the GPS coaxial cable will add an additional 0.2 dB loss to the cable.

The GPS antenna cable should not be routed with high power wires or transmitting antenna cables.

If dual GPS Systems are installed on the aircraft, the GPS coaxial cables should be routed in such a manner to provide maximum separation between the two GPS coaxial cables.

3.3.4 GPS Coaxial Cable Connector

The connectors on the GPS coaxial cable should be assembled per the connector manufacturer's assembly instructions.

3.3.5 Approved GPS Antennas

Model Number	Description	Supplier
CI-428-200	GPS WAAS Antenna	Cobham (Comant)
CI-2580-200	VHF/GPS WAAS Antenna	Cobham (Comant)
CI-2728-410	VHF/GPS/XM Antenna	Cobham (Comant)
GA-35	GPS/WAAS Antenna	Garmin
GA-36	GPS/WAAS Antenna	Garmin
GA-37	GPS/WAAS Antenna	Garmin
GA-56A	GPS/WAAS Antenna	Garmin
GA-56W	GPS/WAAS Antenna	Garmin
GA-57	WAAS/XM Antenna	Garmin
A33 (AT575-9UW)	GPS/WAAS Antenna	Garmin / AeroAntenna
A34	GPS/WAAS Antenna	Garmin / AeroAntenna
AV-801	GPS/WAAS Antenna	RAMI
AT575-93AVW-TNCF-000-RG-27-NM	GPS/WAAS Antenna	AeroAntenna Technology

Table 45 Approved GPS Antennas for SBAS Operation

The IFD can be interfaced to all TSO-C190 antennas and the approved antennas listed in the table above. If connected to an approved WAAS Antenna, the IFD is approved for TSO-C146d Gamma 3 operation.

The IFD5XX/4XX/ATLAS can be interfaced to non-WAAS antennas but the system will not be approved for any type of WAAS operations. In this case, the Antenna Type selection as described in Section 7.5.12 must be selected as "Non-WAAS". This will result in the FMS functionality of the IFD inhibiting selection of any WAAS (SBAS) approach in the database.

Installing a new GPS antenna listed in Table 45 requires additional structural approval beyond the scope of this manual.

3.3.6 GPS Interference

After installing the IFD System, the GPS antenna must be tested to ensure no interference is present. The GPS Antenna System is subject to interference from VHF COM transceiver, Emergency Locator Transmitter (ELT) antenna, or Direction Finder (DF) receiver which can radiate harmonics that can potentially interfere with the GPS antenna.

If a VHF Communication transceiver is found to be the problem, installing a 1.57542 GHz notch filter may help to reduce the problem.

3.3.7 Ground Plane

The GPS Antenna should be mounted on a minimum of 8 x 8 inch metal surface or ground plane.

3.3.8 Dual IFD Installations

If the aircraft has dual IFD, the aircraft is permitted to have a non-WAAS system and a WAAS system installed, however, if the two antennas are not of the same type (i.e. dual non-WAAS or dual WAAS installation), then FMS-related data (flight plans, waypoints, routes, etc) will not be shared between IFD units.

3.3.9 Anti-Ice Protection

If the aircraft is approved for flight into known icing, verify the GPS antenna is installed in location that is not susceptible to ice buildup or complies with FAA AC 20-138() paragraph 13-2.

3.4 VHF Communication Antenna

Note: This section is N/A for the IFD510/545/410 and Atlas FMS Only units.

The VHF communication antenna should be installed using this manual, FAA AC 43.13-(), AC 20-67B and the antenna manufacturer's guidance.

The antennas should be installed to allow maximum separation between antennas. If possible, one antenna should be installed on the top of the aircraft, and the other on the bottom of the aircraft.

3.4.1 Antenna Environmental Qualifications

Verify the antenna is appropriately qualified to be installed on the aircraft. Reference the antenna manufacturer's RTCA DO-160(x) qualification form.

3.4.2 VHF Communication Cable

The antenna cable should be RG-142B, RG-400, or an equivalent 50Ω coaxial cable.

3.4.3 VHF Coaxial Cable Connector

The connectors on the VHF communication coaxial cable should be assembled per the connector manufacturer's assembly instructions.

3.4.4 Voltage Standing Wave Ratio

The VSWR should not exceed 2:1 over the VHF communication radio frequency range. A VSWR over 2:1 may result in loss in transmitting power up to 50%.

3.4.5 VHF Antenna

The VHF Communication Antenna should meet one of the following Technical Standard Orders (TSO): TSO-C37(), TSO-C38(), TSO-C169().

3.4.6 Antenna Ground Plane

The VHF Communication Antenna should be mounted on a minimum of 18 x 18 inch metal surface or ground plane.

3.5 Navigation Antennas

Note: This section is N/A for the IFD510/545/410 and Atlas FMS Only units.

3.5.1 VOR/LOC Antenna

The NAV Antenna should be a standard 50Ω horizontally polarized antenna. The VOR/LOC antenna should be installed using the manufacturer's installation instructions and FAA AC 43.13-().

The VOR/LOC Antenna should meet Technical Standard Order (TSO): TSO-C36 (), TSO-C40 ().

3.5.2 Navigation Coaxial Cable

The antenna cable should be made of RG-142B, RG-400, or an equivalent 50Ω coaxial cable.

3.5.3 Navigation Coaxial Cable Connector

The connectors on the VHF navigation coaxial cable should be assembled per the connector manufacturer's assembly instructions.

3.5.4 Diplexer

The IFD requires separate Glideslope and Navigation antenna inputs. A diplexer will be required if a single navigation coax delivers both VHF navigation and Glideslope navigation signals to the IFD location, such as if a combined Nav/Glideslope antenna is used, or a Nav/Glideslope diplexer is installed to combine signals at the antenna location. The diplexer should be installed per the manufacturer's installation manual.

The Diplexer should be located in a position on the aircraft to minimize the amount of coaxial cable required.

3.6 Glideslope Antenna

Note: This section is N/A for the IFD510/545/410 and Atlas FMS Only units.

The Glideslope Antenna should be standard 50Ω horizontally polarized antenna. The Glideslope antenna should be installed using the manufacturer's installation instructions and FAA AC 43.13-(). The IFD has separate VOR/LOC and Glideslope antenna inputs. See Diplexer text in Section 3.5.4.

3.6.1 Glideslope

The Glideslope Antenna should also be installed with a clear line of sight. The Glideslope Antenna should meet Technical Standard Order (TSO): TSO-C34().

4. Electrical Installation

The electrical wiring should be installed in accordance with FAA AC 43.13-1B Chapter 11, sections 8 through 13 and in accordance with this manual. The following section will describe requirements for the electrical wiring when installing the IFD.

4.1 Wire Type

MIL-C-27500 and MIL-W-22759 wire is recommended. Select the appropriate wire type and size for the aircraft type and installation location per FAA AC 43.13-1B.

4.2 Wire and Connector Identification

Wires and connectors should be marked per FAA AC 43.13-1B.

4.3 Wire Routing

All wires and wire bundles must be routed and secured in such a way to eliminate risk of mechanical damage and minimize exposure to heat and fluids. Also, consider the following when installing wire harnesses in the aircraft:

- In dual GPS installations, route wire harnesses separately to prevent dual GPS failures
- Do not route harness near high power electrical lines
- Equipment should be installed with separation between redundant systems to prevent loss of navigation due to a single event

4.4 Shield Grounds

All shield grounds should be grounded using the ground block on the IFD5XX/IFD4XX tray backplate, or the ground screw on the Atlas chassis. Shield grounds should be as short as possible (shorter than 3.0", if possible)

Shield grounds on non-Avidyne equipment should be grounded per the manufacturer's installation instructions. In the absence of any installation data, the shield wires can be connected to the connector backshell or aircraft ground.

4.5 Wire Harness Overbraid

Copper overbraid is not required on the IFD wire harness. However, in the following cases, copper overbraid is required.

4.5.1 Existing Equipment

If interfacing to any existing avionics equipment with copper overbraid over the wire harness, it must be installed on all new wiring to that existing piece of equipment. The copper overbraid must meet the specification in Section 4.5.3.

4.5.2 Severe Lightning Transient Environment

Aircraft Installations where the aircraft actual transient level is higher than the IFD equipment transient design level must install copper overbraid on the entire IFD wire

harness. This does not include the antenna coaxial cables. The copper overbraid must be installed per Section 4.5.3.

The Approved Model List for the STC will indicate if an aircraft is required to install wire harness overbraid on the IFD wiring. Note: Overbraid is not required on VFR only installations as defined in Section 2.1.1.

4.5.3 Copper Overbraid Installation

The copper overbraid must be a minimum 90% optical coverage per ASTM-B-33. The overbraid must be grounded at both ends. If the aircraft wiring passes through wire disconnects or bulkheads, the overbraid should be continued on each segment.

The wire harness overbraid should also be installed per FAA AC 43.13-1B Chapter 11-189.

4.6 IFD Connectors

The following special tools may be needed during installation of the IFD:

Connector Number	Connector Part number	Contact Part Numbers	Crimp Tool	Die/ Positioner	Extraction Tool	Insertion Tool
P1001	M24308/4- 268()	M39029/58-360 (ORG/BLU/BLK)	M22520/02-01	M22520/2-09	M81969-1-04	M81969/1-04
P1002	M24308/2-3()	M39029/63-368 (ORG/BLU/GRY)	M22520/02-01	M22520/2-08	M81969/1-02	M81969/1-02
P1006	M24308/4- 266()	M39029/58-360 (ORG/BLU/BLK)	M22520/02-01	M22520/2-09	M81969-1-04	M81969/1-04
P1050	M24308/4- 268()	M39029/58-360 (ORG/BLU/BLK)	M22520/02-01	M22520/2-09	M81969-1-04	M81969/1-04
Ground Block IFD4XX/5XX only	583861-7 (TE Connectivity)	5-583853-4 (TE Connectivity)	91535-1 (TE Connectivity)		91073-1 (TE Connectivity)	

Table 46 D-Sub Connector Tools

NOTE: The P1050 is available on the IFD5XX and Atlas Series only.

NOTE: For Atlas (700-00194-XXX) only - The P1050 connector is keyed blocking pins 19, 20, 32, 33, 46 and 47 for connector orientation purposes.

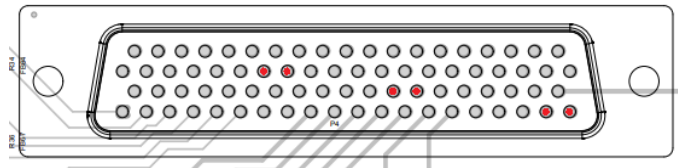

NOTE: Interconnect diagrams in Appendix D show these pins used as grounds. For Atlas (700-00194-XXX) Installations DO NOT USE.

4.7 Byteflight Digital Data Bus Consideration – Dual IFD Installations

Dual IFD installations use a Byteflight digital Databus protocol when connected via RS-232 Channel 3 and configured for CrossSync. The following must be considered for replacement and new installations.

4.7.1 Databus Wiring - Replacement Installations

For installations that are replacing two previously connected GNS4XX/5XX systems, the Byteflight digital Databus is capable of using the pre-existing wiring between the two pre-existing trays with no additional wiring or modifications required. All bus termination is built into the IFD units. However, the existing wire length on the CrossSync connection must not exceed 8 feet in length on IFD RS-232 Channel 3 on P1001. Installations with longer installation lengths between IFD units must use Byteflight cable. The ByteFlight wire is available from Avidyne, reference Table 40.

Installations with significant amount of Byteflight data interruptions should consider installing Byteflight cable.

4.7.2 Databus Wiring – New Installations

For all new installations of dual IFDs (not replacing pre-existing GNS4XX/5XX systems), the recommended wiring for the RS-485 data protocol is shielded twisted- pair cable with an approximate characteristic impedance of 100-120 Ohms. The wire material must meet 14 CFR 23.1359 (c).

4.8 Circuit Protection

Circuit Breakers must be installed in a location easily accessible to the pilot and must be resettable trip free devices. The Circuit Breaker must be clearly identified and visible under all lighting conditions. Circuit breaker size is identified in installation data shown in Appendix D: Electrical Interface Drawings. Note that 14v aircraft may be required to replace the installed circuit breaker and power wiring to accommodate the IFD.

4.9 Power Distribution

Note: The references in the below images to the COM block are N/A for the IFD510/545/410

Aircraft installing one IFD should connect the power and grounds as shown in Figure 5.

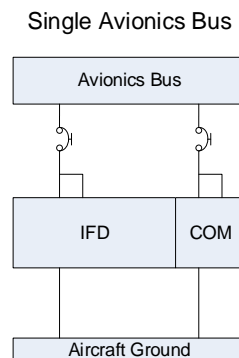

Figure 5 IFD Power Distribution

Aircraft with a maximum certified gross takeoff weight less than 6000 pounds must connect the dual IFD as shown in Figure 6.

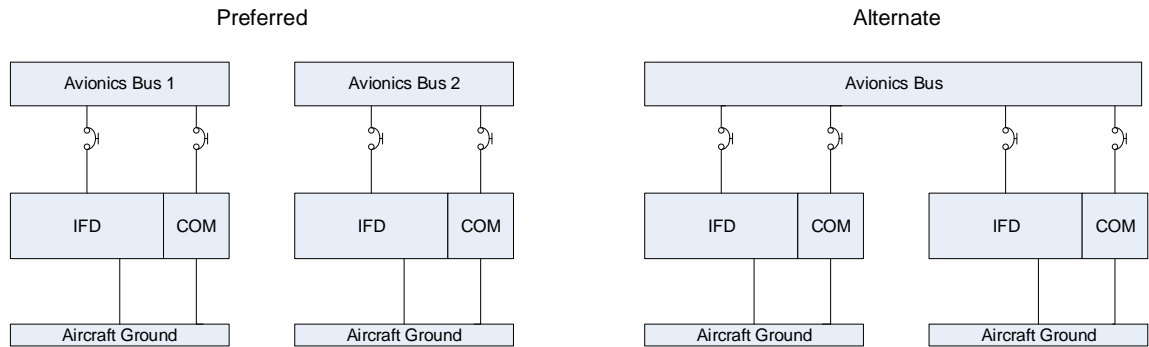

Figure 6 Dual IFD Power Distribution (Aircraft <6000 lbs)

Aircraft with a maximum certified gross takeoff weight greater than 6000 pounds must install the dual IFD as shown in Figure 7.

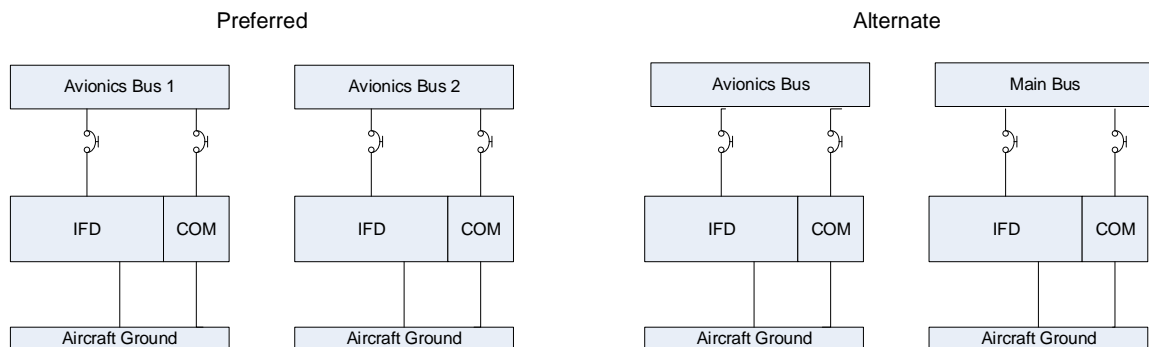

Figure 7 Dual IFD Power Distribution (Aircraft >6000 lbs)

If installing a 3rd party NAV and/or COM and IFD, connect the IFD as shown in Figure 8.

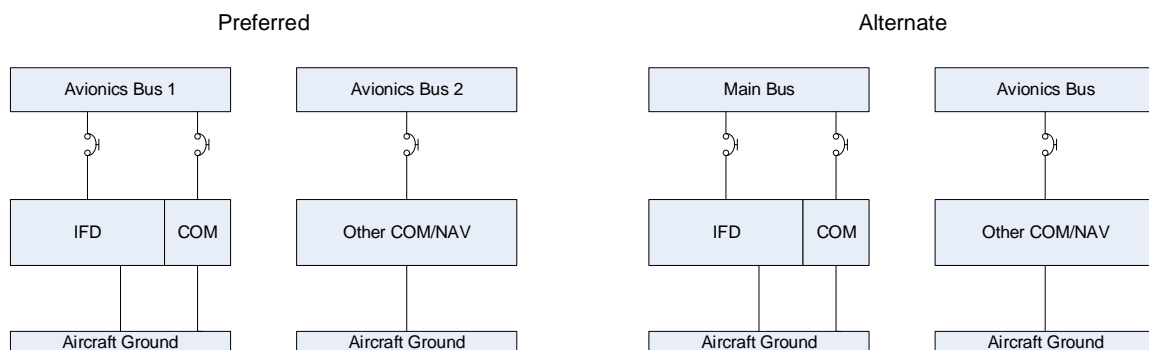

Figure 8 Dual NAV/COM Aircraft Bus Installation (Aircraft >6000 lbs)

The installer is responsible for preservation of multiple power busses on the aircraft in accordance with manufacturer's original design and the requirements of 14 CFR Part 23. This includes maintaining electrical power to essential equipment.

4.10 Electrical Load Analysis

Prior to installing the IFD, an electrical load analysis (ELA) must be performed. The aircraft’s electrical load should be less than 80% of the total generator output following the IFD installation, reference Section 1.5 for IFD power requirements. Also reference FAA AC 43.13-2B Paragraph 208 for more information on performing an aircraft electrical load analysis.

The purpose of the ELA is to show compliance to 14 CFR §23.1351 and §23.1353 (h).

4.11 Low Power Behaviors

The IFD can accept input power ranging from 9VDC to 33VDC but has the following low power behaviors.

Functions are restored if the IFD input voltage rises 1VDC above threshold voltage for 1 second.

Input Voltage Level	Behavior
19.9VDC	16W VHF radio output power reduces to 10W *
≥ 18VDC	High power USB charging (dedicated charging port drawing 2.1A).
< 18VDC	USB port drops from High power USB charging to Low power USB charging (dedicated charging port drawing 1.0A).
12.75VDC	USB port is turned off (no charging available).
11.5VDC	Bezel and LCD display dimmed down to 25% and a yellow “Low Volts” CAS message is presented.
10.9VDC	VHF radio output power reduces to 6W *
10.0VDC	VHF radio output power reduces to 4W *
9VDC	Start a 60 second power down sequence and a red “Low Volts Off in <x> sec” CAS message is presented. With 5 seconds to go until power down, the full power down message is overlaid in the middle of the display.

*N/A for IFD510/545/410 and Atlas FMS Only units

Table 47 IFD Low Power Behavior

5. Mechanical Installation

This section will describe the physical mounting of the IFD or Atlas in the aircraft.

Aircraft installing an IFD for VFR use only, as defined in Section 2.1.1, can install the IFD unit in any location easily accessible to the pilot. However, the IFD installation must not introduce any new hazards. All other installations must follow the guidance below.

5.1 Equipment Location – New Installations

If the IFD is used for IFR navigation, course deviation information and navigation annunciation must be installed in the Pilot's Field of View (FOV). The FAA has provided clarification regarding the intent of TSO-C146 and acceptable source annunciation location, navigation annunciation, and FOV requirements on similar products in the past. Therefore, the installation data as follows must be followed to maintain compliance with the STC. Otherwise, additional installation approval will be required.

Aircraft requiring two pilots must have this annunciation at each pilot station or unobstructed view of the IFD display. The IFD should be located in a position easily reached by both pilots.

5.1.1 Determining the IFD Field of View

In determining the requirement for remote annunciators, the installer must determine if the IFD location falls within the required pilot field of view. The IFD navigation source selection indication ("GPS" or "VLOC") required field of view is $\pm 30^\circ$ or 13.8" horizontally from the center of the attitude indicator, or centerline of the pilot's seat/yoke. The navigation and TAWS (if enabled) annunciation field of view is approximately $\pm 35^\circ$ or 16.8" horizontally from the center of the attitude indicator. Both of these angles and distances are determined with the pilot seated at a minimum of 24" from the instrument panel. For aircraft without a basic instrument 'T' or an offset control yoke/control, use the center of the pilot's seat as the primary view centerline.

The vertical field of view will be from the top of the instrument panel to the portion of the instrument panel that is immediately below the basic 'T' instruments, reference

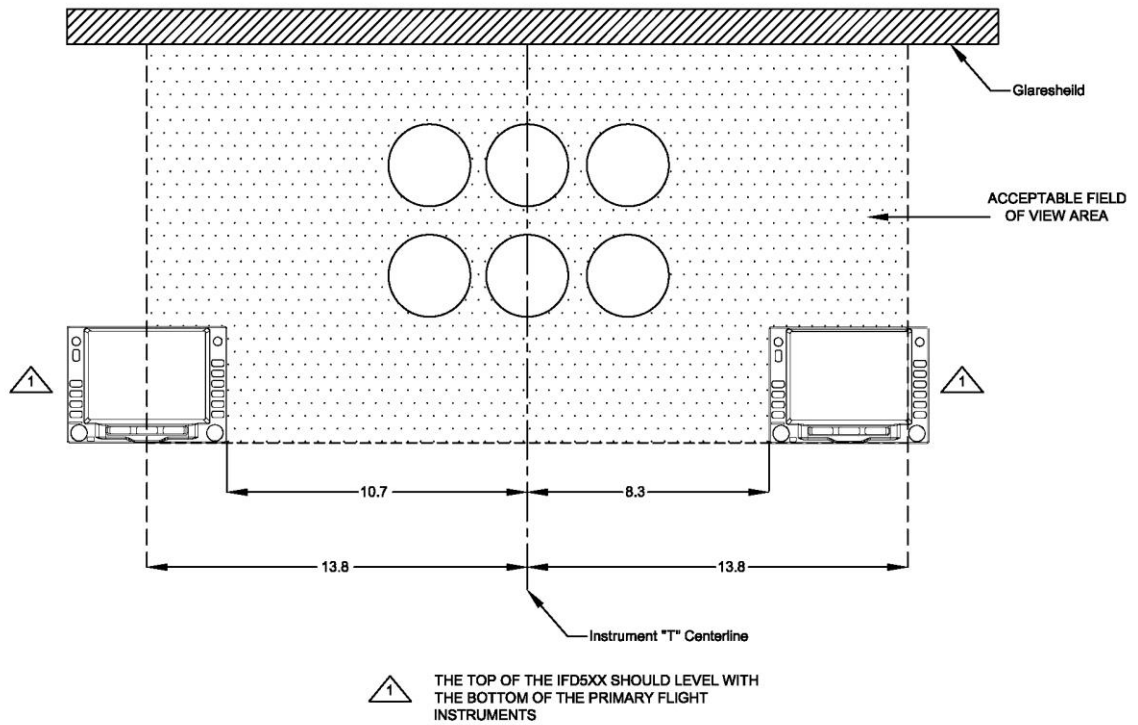

Figure 9. Note, if the existing type certified HSI/CDI/PFD is lower than the basic 'T', use that as the lower limit.

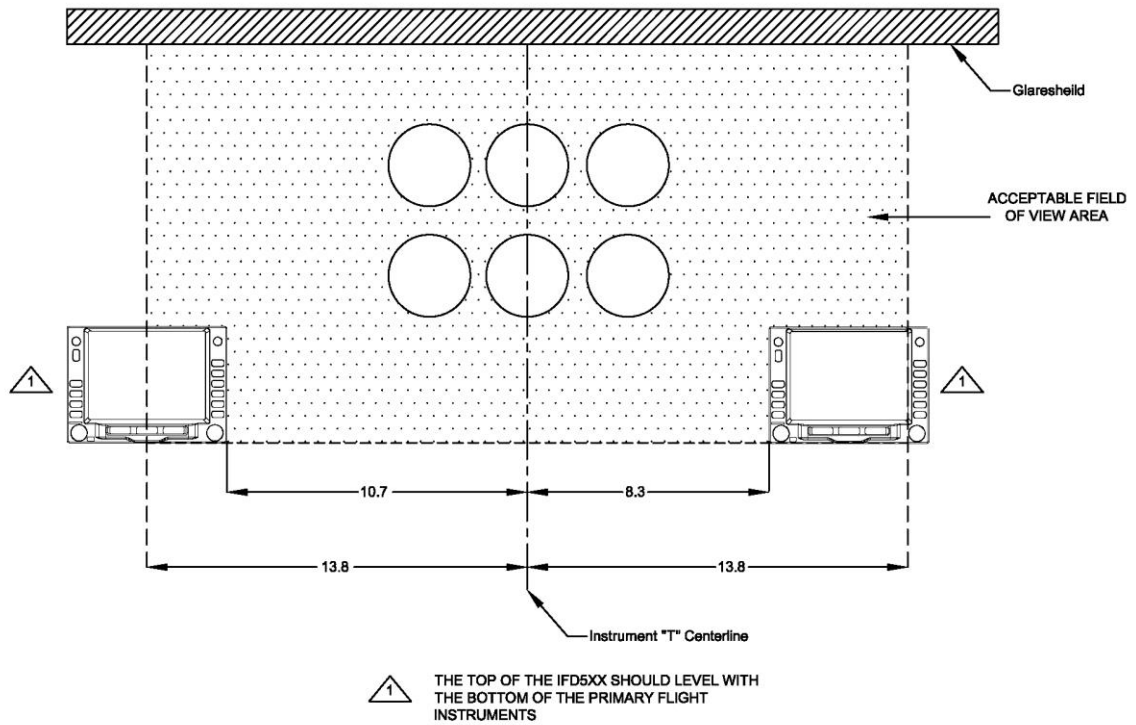

Figure 9 below indicates the acceptable field of view for the IFD5XX/4XX. If the IFD5XX/4XX can be installed in this area, remote navigation annunciation is not required. If the IFD5XX/4XX cannot be installed within the acceptable field of view, the installation must have navigation annunciations installed per Section 5.1.2.

Note: The dimensions shown in

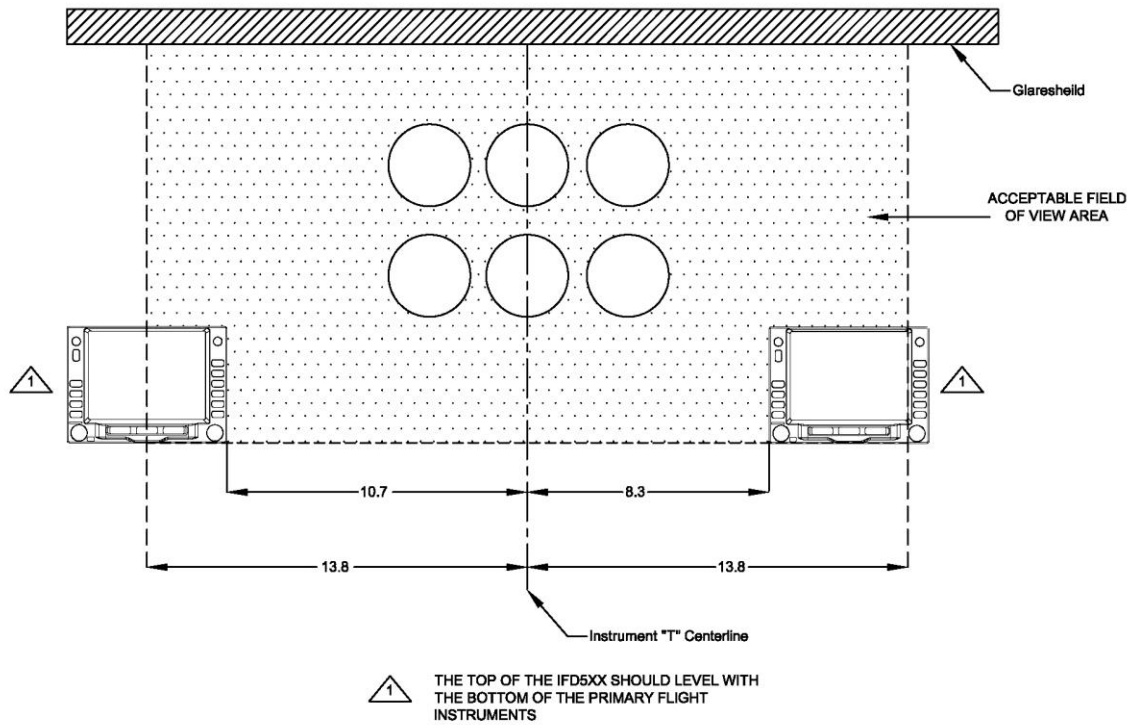

Figure 9 and Figure 10 for the IFD5XX also apply to the IFD4XX.

Note: Atlas units mounted in center console positions will fall outside of the required field of view for annunciations. Panel mounted annunciators are required in the prescribed field of view.

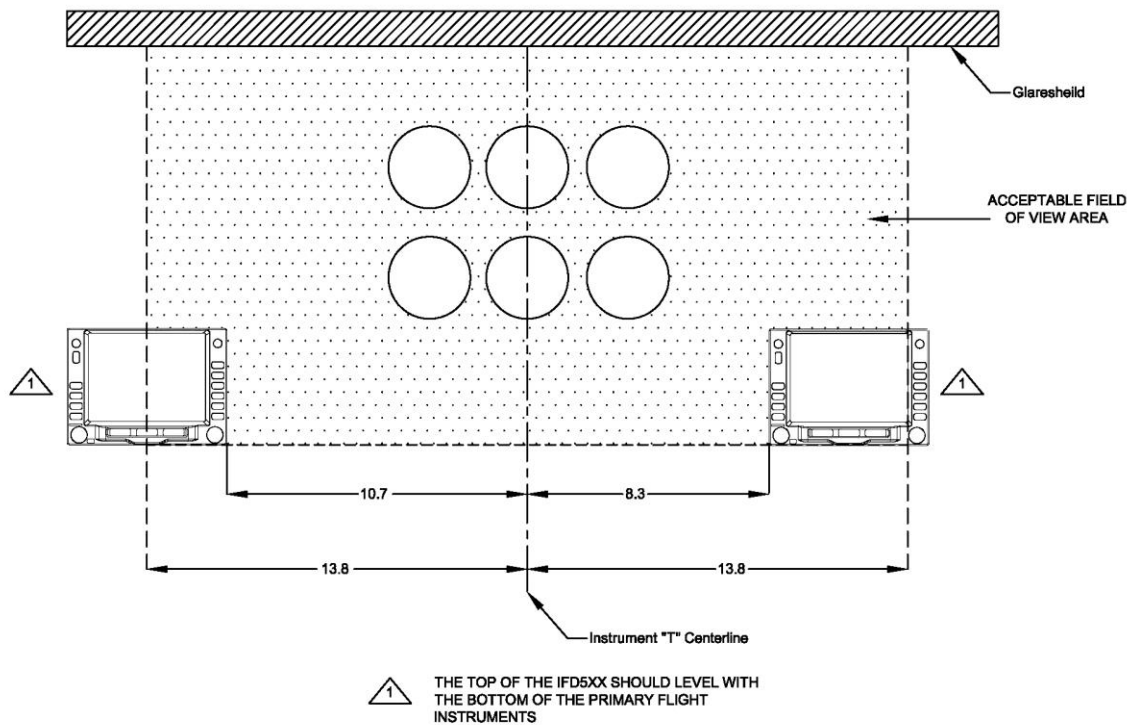

Figure 9 Field of View

5.1.2 Navigation and TAWS (if enabled) Annunciation

The navigation and TAWS (if enabled) annunciations listed in Table 48 must be installed in the Pilot's Field of view. This may be accomplished in several ways. The following are acceptable:

- Use Navigation Annunciation on an existing Primary Flight Display or Horizontal Situation Indicator located in the Pilot's primary field of view. CDI/HSI indicators with navigation annunciation is acceptable (e.g. GI 106, MD200-306, or similar). The CDI/HSI must be located within the primary field of view.

If the IFD5XX/4XX is located within the acceptable field of view, as shown in

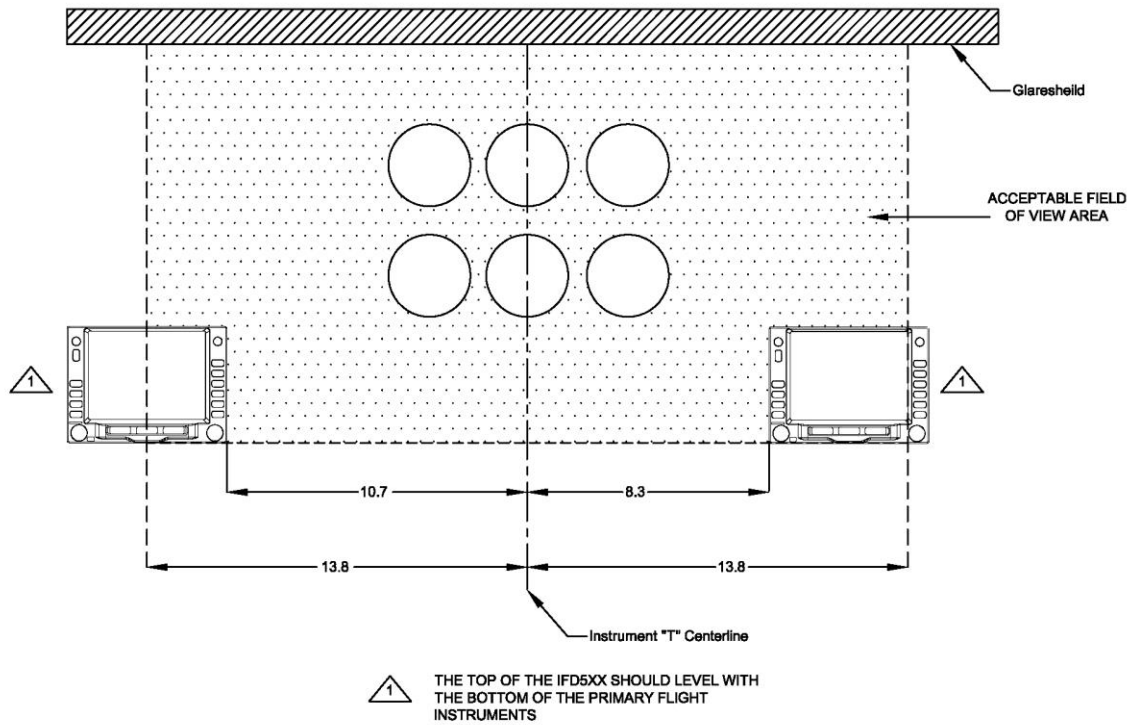

- Figure 9, external annunciation is not needed
- Install external annunciation lights in the acceptable field of view, as shown in Figure 10.

The IFD should have the following annunciation within the Pilot's Field of View when installing an external annunciator:

Navigation Annunciation Type
VLOC Annunciate‡
GPS Annunciate‡
OBS Annunciate (optional)
Waypoint Annunciate
Terminal Annunciate
Approach Annunciate
Message Annunciate
LOI, INTEG, or INTG Annunciate
Terrain N/A **
Terrain Pull Up**
Terrain Caution**
TAWS Inhibit**

Table 48 Navigation and TAWS Annunciation

‡ Must be located ±30° or 13.856", see Section 5.1.1

** w/ Fixed Wing TAWS Enabled

The navigation and/or TAWS annunciators should be readable under all lighting conditions. The annunciators must be able to be tested prior to flight. The field of view in

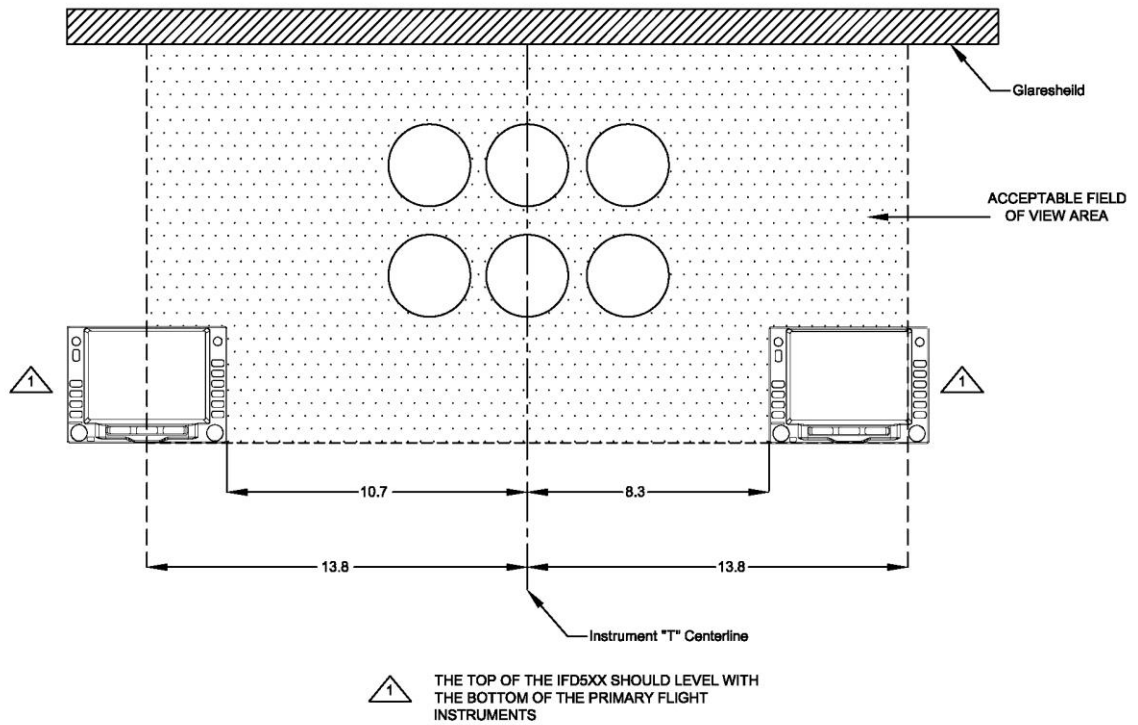

Figure 9 is based on $\pm 35^\circ$ from the Instrument "T" centerline at 24" aft of the panel.

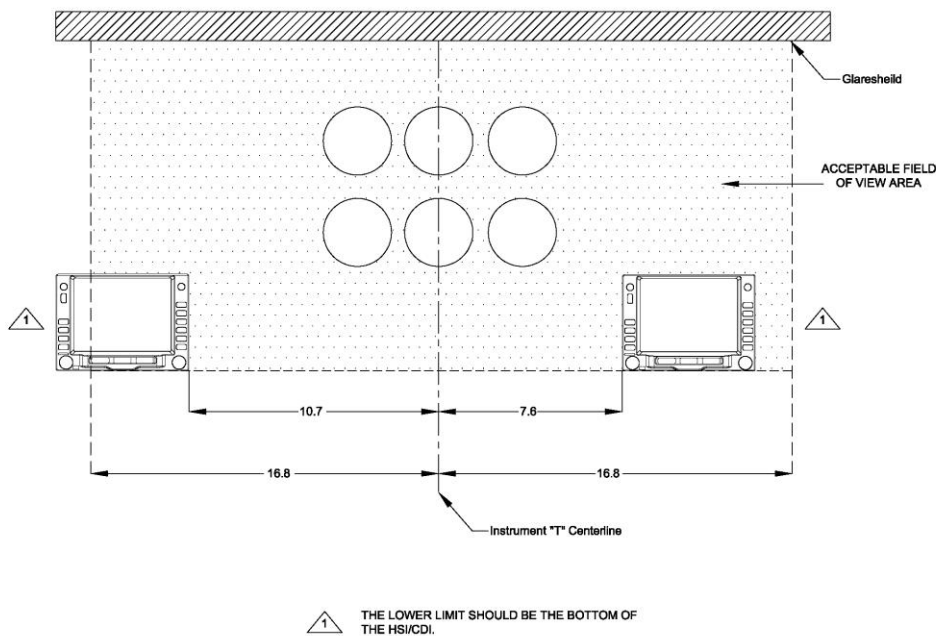

Figure 10 Navigation and TAWS(if enabled) Annunciation Field of View

5.1.3 Course Deviation Indicator

The course deviation information must be located in the Pilot's Primary Field of view if the IFD is used for IFR navigation. Installation of a CDI/HSI requires a separate installation approval.

5.1.4 Instrument Panel Cutout

The IFD5XX and IFD4XX tray is designed to be installed on the backside of the instrument panel. The instrument panel requires either a 6.320" x 4.600" or 6.320" x 2.70" hole for the IFD5XX or IFD4XX respectively. If the instrument panel in the aircraft is considered primary structure, additional installation approval will be required for the instrument panel cutout. The installer is responsible to ensure the structural aspects of this installation meet the requirements of AC 43.13-2B, Chapter 11, Paragraph 1104(a).

5.1.5 Requirements for Tray Installation

The Avidyne Tray must be installed in the aircraft as described below in order to satisfy the structural requirements for the STC. Deviations to these requirements will require separate approval.

1. Rear Tray Support (Instrument Panel)
 - a. The existing instrument panel must be fabricated from 2024-T3 aluminum with a minimum thickness of 0.050" (Note: equivalent or stronger is acceptable). The tray brackets must be fabricated from 3/4" x 3/4" x 1/16" 2024-T3 aluminum angle for mounting the tray, as shown in Figure C - 1 and Figure C - 2.
 - b. If new components are fabricated, the fabrication methods must follow the requirements of FAA Advisory Circular 43.13-1B, Chapter 4 for general airframe fabrication criteria, including hole tolerances, edge distances, rivet spacing, and corrosion protection, and Advisory Circular 43.13-2B Chapters 2 and 11 for structural adequacy.
2. Forward Tray Support
 - a. The Avidyne Tray must have forward support brackets, reference Figure C - 1 or Figure C - 2. The forward support brace must be 0.032" 5052-H32 aluminum. (Note: equivalent or stronger is acceptable)
 - b. If new forward support brackets are fabricated, the fabrication methods must follow the requirements of either Figure C - 1 or Figure C - 2, FAA Advisory Circular 43.13-1B, Chapter 4 for general airframe fabrication criteria, including hole tolerances, edge distances, rivet spacing, and corrosion protection, and Advisory Circular 43.13-2B, Chapters 2 and 11 for structural adequacy.

The IFD5XX tray should be installed using six #6-32 100° flat head screws and self-locking nuts. The IFD4XX tray should be installed using four #6-32 100° flat head screws and self-locking nuts.

5.2 Equipment Location - Replacement Unit

If the IFD is being installed as replacement unit on a previously approved IFR installation, the existing installation location is acceptable and does not require any changes.

5.3 Equipment Location - Atlas Unit

Utilizing an existing dzus rail console, verify that the console structure has not been altered or modified and meets the type design of the installation aircraft. Assure adequate depth is available to accommodate the Atlas unit as well as connectors and associated wire bundles. The installer must determine the airworthiness of the location of any dzus rail mounted equipment that is moved when installing the Atlas unit to meet the required angle of regard for the Atlas display. The captive quarter-turn fasteners in the Atlas unit are utilized to fasten the IFD to the dzus rail structure.

5.4 Angle of Regard

The IFD5XX/4XX should be mounted in a location where the viewing angle of the display does not exceed the following angles: Note: the reference plane for these measurements is the unit itself:

- From the Left: 45°
- From the Right: 45°
- From the Top: 35°
- From the Bottom: 15°

The Atlas should be mounted in a location where the viewing angle of the display does not exceed the following angles:

- From the Left: 45°
- From the Right: 45°
- From the Top: 15°
- From the Bottom: 35°

Note: The Atlas display viewing angles are designed to accommodate a typical center console installation. Angled consoles or console transitions may not meet the stated angle of regard requirements above. Instrument panel installations are not acceptable.

5.5 Unit Installation/Removal

5.5.1 IFD IFD5XX/4XX Installation/Removal

The IFD5XX/4XX should be installed using 3/32-inch hex drive tool. The hex drive is inserted into the hole in the front bezel.

5.5.2 Atlas Installation/Removal

Remove equipment to be replaced from the center console per the instructions of the existing equipment manufacturer. Inspect the center console support structure to ensure no alterations or modifications have been made and it meets type design. Ensure the Avidyne Dzus fastener pattern is compatible with the existing Dzus rails. If evidence of alteration is found, or if Dzus rails are not compatible, separate approval is required.

Record the weight of all equipment removed from the center console Dzus rails, including fasteners and electrical connectors. Verify the weight of the removed equipment exceeds the Atlas installed weight shown in Table 25. If weight of removed equipment is less than the Atlas installed weight, separate approval is required.

Install ATLAS on existing Dzus rails or rack by engaging the 4 Dzus quarter turn fasteners with an appropriately sized flat blade tool.

5.6 Internal Cooling

The IFDXXX units have several internal fans and heat sinks as part of their basic design. The IFDXXX units have intake and exhaust vents on the left and right sides of the chassis with cut outs in the tray to facilitate venting. The left and right sides of the front bezel have intake louvers to help pull ambient cockpit air through the unit. The IFDXXX will benefit from keeping these vents clear of all obstructions.

The Atlas units have intake and exhaust vents on the top and bottom of the chassis and a few louvers on the back of the head unit.

While not necessary, if installation flexibility permits, the units will benefit from these intake and exhaust vents remaining as clear as feasible. In some cases failure to do so can cause an over-temp condition.

5.7 External Cooling

The IFD does not require external cooling; however, additional cooling may prolong product life. A 5/8" diameter air fitting is provided in the rear of the IFD mounting tray, if forced air cooling is installed.

IFD installations in a tightly packed avionics stack should consider installing an electric avionics cooling fan. As a minimum, plan to leave space for clear intake and exhaust venting when able. If a fan is installed, ensure the intake air flow to the fan is not located near the exhaust of other fans or near other hot equipment.

In the event the system feels excessively hot or if an Overtemp Caution Advisory System message is presented on the display, there are some diagnostic tools provided in the IFD to assist in finding more optimal cooling installations. In Maintenance Mode, select the "Status" tab along the bottom edge of the display and then press the "Info" Line Select Key as needed until "Temps" is displayed. Note the hottest source(s) on that page and supply that information to Avidyne Technical Support to include both the source and the associated temperature for follow-on guidance. If a Red CAS message is displayed at a time with the warning, "UNIT OVERTEMP UNIT UNRELIABLE" the IFD must return to Avidyne for servicing.

The metal bezel of the IFD is intentionally designed to radiate heat away from the internal components and out of the unit. This can have the effect of a bezel that may be warm to the touch. This is considered normal. Note that the rubber bezel buttons will not conduct this heat and should not be warm. This condition will be more noticeable on hot days or during long ground runs.

5.8 Electrical Bonding

The electrical bonding between the IFD5XX/IFD4XX tray or the Atlas rear ground screws and aircraft ground should be ≤ 10 milliohm.

5.9 Aircraft Considerations

Installing wires or antennas on a pressurized aircraft, composite aircraft, or with an aircraft certification basis of Amendment 23-45 or later is beyond the scope of this manual and requires additional installation approval, unless the aircraft model is listed on the STC AML.

5.10 Weight and Balance

After installing the IFD, the aircraft's weight and balance must be updated after installation is complete.

For those installations where an IFD5XX/4XX is replacing a GNS530/430 (any variant), since the IFD is within 5% of the weight of the removed GNS530/430 (less than 1 pound difference), no new weight and balance must actually be performed according to AC 43.13-1B Change 1 Acceptable Methods, Techniques, and Practices Aircraft Inspection and Repair (Chapter 10) and AC 120-27E Aircraft Weight and Balance Control.

5.11 Compass Safe Distance

The IFD should be installed 12" or more away from the aircraft's magnetic compass. Perform an aircraft compass swing/calibration after completing the IFD installation.

Note: The 12" minimum distance is a TSO-driven value that is designed to ensure the unit will have no impact on the aircraft compass. If an installation is made where this distance is less than 12", then a compass swing/calibration must be accomplished after completing the IFD installation.

6. System Installation

The following section will describe interfacing the IFD to various other avionics and aircraft equipment.

6.1 Pin Function List

The following Section Lists the Pin function for each connector.

6.1.1 P1001 Main Connector

Pin	Description	Signal Type
1	VLOC Annunciate	Output
2	GPS Annunciate	Output
3	Waypoint Annunciate	Output
4	Terminal Annunciate	Output
5	Approach Annunciate	Output
6	Message Annunciate	Output
7	OBS Annunciate	Output
8	Weight on Wheels (WOW) Output	Output
9	Integrity Annunciate	Output
10	Annunciate D	Output
11	Annunciate E	Output
12	Reserved	Output
13	GPS Select	Output
14	ILS/GPS Annunciate (Approach)	Output
15	Aircraft Power 2	Input
16	Time Mark Out	Output
17	Main Lateral Superflag	Output
18	Main Vertical Superflag	Output
19	Aircraft Power 1	Input
20	Aircraft Power 1	Input
21	Main +Left	Output
22	Main +Right (1.65V COM)	Output
23	Main Lat +Flag	Output
24	Main Lat -Flag (GND)	-
25	Main +To (1.65V Common)	Output

Pin	Description	Signal Type
26	Main +From	Output
27	Main +Up (1.65V Common)	Output
28	Main +Down	Output
29	Main Vertical +Flag	Output
30	Main Vertical -Flag (GND)	-
31	Main OBS Rotor C	Output
32	Main OBS Rotor H(GND)	-
33	Main OBS Stator D	Input
34	Main OBS Stator E (2.5V Common OBS)	Output
35	Main OBS Stator F	Input
36	Main OBS Stator G (2.5V Common OBS)	Output
37	Audio 1 HI (Alert audio)	Output
38	Audio 1 LO (Alert audio)	Output
39	LTG Bus HI	Input
40	LTG Bus LO (GND)	Input
41	GPS RS232 Out 3	Output
42	GPS RS232 In 3	Input
43	Main OBI Clock	Output
44	Main OBI Data	Output
45	Main OBI Sync	Output
46	GPS Arinc-429 Out 1A	Output
47	GPS Arinc-429 Out 1B	Output
48	GPS Arinc-429 In 1 A	Input
49	GPS Arinc-429 In 1 B	Input
50	GPS Arinc-429 In 2 A	Input
51	GPS Arinc-429 In 2 B	Input
52	Audio 2 HI	Output
53	Audio 2 LO	Output
54	GPS RS232 Out 4	Output
55	GPS RS232 In 4	Input
56	GPS RS232 Out 1	Output
57	GPS RS232 In 1	Input

Pin	Description	Signal Type
58	GPS RS232 Out 2	Output
59	GPS RS232 In 2	Input
60	Altitude Common (GND)	-
61	Altitude C4	Input
62	Altitude C2	Input
63	Altitude C1	Input
64	Altitude B4	Input
65	Altitude B2	Input
66	Altitude B1	Input
67	Altitude A4	Input
68	Altitude A2	Input
69	Altitude A1	Input
70	Altitude D4 / Weight on Wheels Input (Helicopter use)	Input
71	OBS Mode Select	Input
72	Aircraft Power 2	Input
73	CDI Source Select	Input
74	COM Remote Recall Forward	Input
75	COM Remote Recall Reverse	Input
76	LTG BUS 2 HI	Input
77	Aircraft GND	-
78	Aircraft GND	-

Table 49 P1001 Pin Description

For fixed-wing aircraft, the IFD5XX/4XX and Atlas use GPS velocity and AGL altitude to determine In-Air/On-Ground state. The WOW transition output logic is on P1001 Pin 8

On-Ground = 30kts and below

In-Air = 50kts and above

6.1.2 P1002 Communication Connector

Note: This connector is not used in the IFD510/545/410 or Atlas FMS Only units

Pins	Description	Signal Type
1	Reserved	-
2	Ethernet 1 TX+	Output
3	Ethernet 1 TX-	Output
4	COM Microphone Key	Input
5	Intercom Microphone Audio HI	Input
6	COM Microphone Audio HI	Input
7	COM Audio HI	Output
8	Ethernet 1 RX+	Input
9	Ethernet 1 RX-	Input
10	Synchro X	Input
11	Aircraft Power	Input
12	Aircraft Power	Input
13	Synchro Reference Signal +	Input
14	Transmit Interlock (Unused)	Input
15	COM Remote Transfer	Input
16	Reserved	-
17	Intercom Microphone Audio LO	Input
18	COM Microphone Audio LO	Input
19	COM Audio LO	Output
20	Reserved	-
21	Aircraft GND	-
22	Aircraft GND	-
23	Synchro Y	Input
24	Synchro Z	Input
25	Synchro Reference Signal -	Input

Table 50 P1002 Pin Description

6.1.3 P1006 Navigation Connector

Note: This connector is not used in the IFD510/545/410

Pins	Description	Signal
1	VOR/LOC +To	Output
2	VOR/LOC +From (VOR/LOC 2.5V Common)	Output
3	VOR/LOC +Flag	Output
4	VOR/LOC -Flag (VOR/LOC 2.5V Common)	Output
5	VOR/LOC +Left	Output
6	VOR/LOC +Right (VOR/LOC 2.5V Common)	Output
7	Com Monitor Audio HI	Output
8	VOR/LOC Composite Out	Output
9	VOR OBS Rotor C	Output
10	VOR OBS Rotor H (GND)	-
11	VOR OBS Stator E/G (VOR/LOC 2.5V Common)	Output
12	VOR OBS Stator F	Input
13	VOR OBS Stator D	Input
14	Parallel DME - 8MHz	Output
15	VOR/LOC Superflag	Output
16	VOR/ILS Audio HI	Output
17	VOR/ILS Audio LO	Output
18	Serial DME - Clock	Output
19	Serial DME - Data	Output
20	Ser DME-Chan REQ/PAR DME - 4MHz	Input/output
21	Ser DME-RNAV Mode/PAR DME - 2MHz	Input/output
22	DME Common	Input
23**	VOR/ILS Arinc-429 Out B	Output
24**	VOR/ILS Arinc-429 Out A	Output
25	VOR OBI Clock	Output
26	VOR OBI Sync	Output
27	VOR OBI Data	Output
28	VLOC Remote Transfer	Input
29	ILS Energize	Output
30	Glideslope +Flag	Output
31	Glideslope +Down/-Flag (Glideslope 2.5V Common)	Output
32	Glideslope +Up	Output
33	Parallel DME - 1MHz	Output
34	Com Monitor Audio LO	Output
35	VOR/ILS Arinc-429 In B	Input
36	VOR/ILS Arinc-429 In A	Input
37	Parallel DME - 800KHz	Output
38	Glideslope Superflag	Output

Pins	Description	Signal
39	Parallel DME - 400KHz	Output
40	Parallel DME - 200KHz	Output
41	Aircraft GND	-
42	Parallel DME - 100KHz	Output
43	Parallel DME - 50KHz	Output
44	Aircraft Power	Input

Table 51 P1006 Pin Description

** GLAS Enable only

6.1.4 P1050 Additional I/O Connector

Please note: This connector is not available on the IFD4XX.

Pins	Description	Signal
1	TAWS Inhibit IN	Input
2	TAWS Audio Inhibit IN	Input
3	HTAWS Reduced Protection Mode	Input
4	HTAWS Aural Suppression	Input
5	Spare Input 2	Input
6	Spare Input 1	Input
7	Reserved	-
8	Reserved	-
9	Terrain Not Available Annunciate	Output
10	Terrain Warning Annunciate	Output
11	Terrain Caution Annunciate	Output
12	TAWS Inhibit Annunciate	Output
13	HTAWS Reduced Protection Annunciate	Output
14	Spare Annunciate 1	Output
15	TAWS Audio Active Out	Output
16	Reserved	-
17-21*	Ground	-
22-39*	NO CONNECT	-
40	ARINC 453 RX+	Input
41	ARINC 453 RX -	Input
42	GPS ARINC-429 Out 2A	Output
43	GPS ARINC-429 Out 2B	Output
44	VOR/ILS ARINC 429 OUT 3A**	Output
45	VOR/ILS ARINC 429 OUT 3B**	Output
46-59*	NO CONNECT	-
60	RS232 Out 5	Output
61	RS232 IN 5	Input
62	RS232 Out 6	Output
63	RS232 IN 6	Input

Pins	Description	Signal
64	Ground	-
65-76	NO CONNECT	-
77	RS170 Video IN	Input
78	Ground	Input

Table 52 P1050 Pin Description

** GLAS Enable only

*Note: Atlas only - P1050 connector is keyed blocking pins 19, 20, 32, 33, 46 and 47 for connector orientation purposes.

6.1.5 Altitude Gray Code

Altitude Gray code input is connected on the following pins:

Description	Connector	Pin	Signal Type
Altitude D4	P1001	70	Input
Altitude A1	P1001	69	Input
Altitude A2	P1001	68	Input
Altitude A4	P1001	67	Input
Altitude B1	P1001	66	Input
Altitude B2	P1001	65	Input
Altitude B4	P1001	64	Input
Altitude C1	P1001	63	Input
Altitude C2	P1001	62	Input
Altitude C4	P1001	61	Input
Altitude Common	P1001	60	Input

Table 53 Altitude Gray Code Description

NOTE: Some transponders and altitude encoders do not have internal isolation diodes to prevent the unit from pulling the encoder lines to ground when the unit is off. These units will require the installation of a diode into harness for each encoder line.

6.1.6 Heading Input

Note: This section is N/A for the IFD510/545/410 and Atlas FMS Only units.

The IFD can accept a 3-wire ARINC 407 Synchro heading input on the following connectors and pins:

Description	Connector	Pin	Signal Type
Synchro X	P1002	10	Input
Synchro Reference Signal + (26VAC 400 Hz)	P1002	13	Input
Synchro Y	P1002	23	Input
Synchro Z	P1002	24	Input
Synchro Reference Signal - (GND)	P1002	25	Input

Table 54 Synchro Heading Input

6.1.7 Main Course Deviation Indicator Output

The main indicator displays both lateral and vertical deviations, TO/From, and Flag indications from the NAV and GPS receivers.

6.1.7.1 Lateral/Vertical Deviations

The lateral and vertical deviations are on the following connector and pins:

Description	Connector	Pin	Signal Type
Main +Left	P1001	21	Output
Main +Right	P1001	22	Output
Main +Up	P1001	27	Output
Main +Down	P1001	28	Output

Table 55 Main Course Deviation Output

6.1.7.2 TO/FROM Indication Flag

The To/From Flag indication flags are on the following connector and pins:

Description	Connector	Pin	Signal Type
Main +To	P1001	25	Output
Main +From	P1001	26	Output

Table 56 Main TO/From Flag Output

6.1.7.3 Navigation Flags

The Navigation Flags is on the following connector and pins:

Description	Connector	Pin	Signal Type
Main Lateral +Flag	P1001	23	Output
Main Lateral -Flag	P1001	24	Output
Main Vertical +Flag	P1001	29	Output
Main Vertical -Flag	P1001	30	Output

Table 57 Main Navigation Flag Output

6.1.7.4 Navigation Superflags

The Navigation Superflags is on the following connector and pins:

Description	Connector	Pin	Signal Type
Main Lateral Super Flag	P1001	17	Output
Main Vertical Super Flag	P1001	18	Output

Table 58 Main Navigation Superflag Output

Superflag outputs system voltage when valid and <.25 VDC when not valid. This output is capable of driving 500mA at 28 VDC or 250mA at 14 VDC. Power is from P1006 pin 44

6.1.7.5 OBS

The OBS is on the following connector and pins:

Description	Connector	Pin	Signal Type
Main OBS Rotor C	P1001	31	Output
Main OBS Rotor (Ground)	P1001	32	Output
Main OBS Stator D	P1001	33	Input
Main OBS Stator E	P1001	34	Output
Main OBS Stator F	P1001	35	Input
Main OBS Stator G	P1001	36	Output

Table 59 Main OBS Output

6.1.7.6 *Annunciators Electrical Output*

Description	Connector	Pin	Signal Type
VLOC Annunciate	P1001	1	Output
GPS Annunciate	P1001	2	Output
Waypoint Annunciate	P1001	3	Output
Terminal Annunciate	P1001	4	Output
Approach Annunciate	P1001	5	Output
Message Annunciate	P1001	6	Output
OBS Annunciate	P1001	7	Output
Integrity Annunciate	P1001	9	Output
LNAV GPS Select	P1001	13	Output
ILS/GPS Approach	P1001	14	Output

Table 60 Annunciator Output

All outputs sink up to 500 mA when activated.

Some legacy autopilots require a “delayed ILS” discrete input. This function is used to prevent an autopilot from engaging too quickly upon glideslope capture. The output prevents the autopilot from an immediately pitch up or down to center the glideslope needle.

Rockwell Collins VIR-30/32/432/433 VHF navigation sensors have this discrete output. It is incorporated to switch an external relay in the flight guidance system when an ILS frequency is selected, otherwise it is an open.

When replacing one of the radios listed above, it is imperative to determine if the delayed ILS output is being used with the installed autopilot.

To accomplish this function using an IFD or Atlas:

ILS/GPS Approach: P1001 Pin 14 will replace this existing output.

ILS Approach: P1006 Pin 29 for VHF approach sensor approach operations only (see Table 51).

6.1.7.7 *Switch Inputs*

Description	Connector	Pin	Signal Type
OBS Mode Select	P1001	71	Input
CDI Source Select	P1001	73	Input

Table 61 Switch Inputs

The inputs are considered active if voltage to ground <1.9V or resistance to ground <375 Ω. These inputs are considered inactive if voltage to ground is 11-33 VDC.

6.1.7.8 Time Mark Out

Description	Connector	Pin	Signal Type
Time Mark Out	P1001	16	Output

Table 62 Time Mark Output

Outputs a $1\text{ms} \pm 1\mu\text{s}$ wide pulse once every $1.0\text{ Second} \pm 2\text{ ms}$. Output sources 1 mA at $>3.8\text{ V}$ and sinking 1 mA at less than 0.4 V .

6.1.8 Serial Data

6.1.8.1 RS-232

Description	Connector	Pin	Signal Type
RS-232 Output 1	P1001	56	Output
RS-232 Input 1	P1001	57	Input
RS-232 Output 2	P1001	58	Output
RS-232 Input 2	P1001	59	Input
RS-232 Output 3 *	P1001	41	Output
RS-232 Input 3 *	P1001	42	Input
RS-232 Output 4	P1001	54	Output
RS-232 Input 4	P1001	55	Input
RS-232 Output 5‡	P1050	60	Output
RS-232 Input 5‡	P1050	61	Input
RS-232 Output 6‡	P1050	62	Output
RS-232 Input 6‡	P1050	63	Input

Table 63 RS-232 Input / Output

*RS-232 Port 3 Output and Input should only be used for cross-synch of two IFDs. In single IFD installations leave RS-232 Port 3 Output and Input set to Off.

‡IFD5XX and Atlas Only

6.1.9 ARINC 429

Description	Connector	Pin	Signal Type
GPS ARINC 429 OUT 1A	P1001	46	Output
GPS ARINC 429 OUT 1B	P1001	47	Output
GPS ARINC 429 IN 1 A	P1001	48	Input
GPS ARINC 429 IN 1 B	P1001	49	Input
GPS ARINC 429 IN 2 A	P1001	50	Input
GPS ARINC 429 IN 2 B	P1001	51	Input
VOR/ILS ARINC 429 OUT A	P1006	24	Output
VOR/ILS ARINC 429 OUT B	P1006	23	Output
VOR/ILS ARINC 429 IN A	P1006	36	Input
VOR/ILS ARINC 429 IN B	P1006	35	Input
GPS ARINC 429 OUT 2A*	P1050*	42	Output
GPS ARINC 429 OUT 2B*	P1050*	43	Output
VOR/ILS ARINC 429 OUT 3A**	P1050**	44	Output
VOR/ILS ARINC 429 OUT 3B**	P1050**	45	Output

Table 64 ARINC 429 Input / Output

* IFD5XX and Atlas only, ** GLAS Enabled only

6.1.9.1 GPS ARINC Output

The data output on the GPS ARINC out port depends on the configuration of the unit. Below is a list of configurations and label outputs for each:

1. ARINC 429
2. GAMA 429
3. GAMA 429 Graphics
4. GAMA 429 Graphics w/Int
5. GAMA 429 Pro Line 21
6. GAMA 429 Sextant
7. GAMA 429 Bendix King
8. GAMA 429 Thales
9. GAMA 429 Non-Standard
10. ARINC 743A
11. ARINC 743A+
12. Becker BXT Ctl

****Note:** Labels 102 (Selected Altitude), 117, 126, 322 and 327 are enabled or disabled via a separate Mx setting

Label #	Parameter Name	1	2	3	4	5	6	7	8	9	10	11	12
001	Distance to Go	•	•	•	•	•	•	•	•	•			
002	Time to Go	•	•	•	•	•	•	•	•	•			
012	Ground Speed	•	•	•	•	•	•	•	•	•			
031	Becker Xpdr Control												•
057	User Range Error											•	
060	GPS System Information											•	
061	Pseudo Range											•	
062	Pseudo Range Fine											•	
063	Range Rate											•	
064	Delta Range											•	
065	SV Position X											•	
066	SV Position X Fine											•	
070	SV Position Y											•	
071	SV Position Y Fine											•	
072	SV Position Z											•	
073	SV Position Z Fine											•	
074	UTC Measurement Time											•	
074	Data Record Header		•	•	•	•	•	•	•	•			
075	Active Waypoint From/To Data		•	•	•	•	•	•	•	•			
076	MSL Altitude								•		•	•	•
100	Selected Course 1	•	•	•	•	•	•	•	•	•			
101	HDOP								•		•	•	•
102	VDOP								•		•	•	•
102	Selected Altitude		•	•	•	•	•	•	•				
103	Track Angle								•		•	•	•

Label #	Parameter Name	1	2	3	4	5	6	7	8	9	10	11	12
110	Latitude								•		•	•	•
111	Longitude								•		•	•	•
112	Ground Speed								•		•	•	•
113	Message Checksum		•	•	•	•	•	•	•	•			
114	Desired Track	•	•	•	•	•	•	•	•	•			
115	Waypoint Bearing	•	•	•	•	•	•	•	•	•			
116	Cross Track Distance	•	•	•	•	•	•	•	•	•			
117	Vertical Deviation		•	•	•	•	•	•	•	•			
120	Latitude, Fine								•		•	•	•
121	Horizontal Command	•	•	•	•	•	•	•	•	•			
121	Longitude, Fine								•		•	•	•
125	Greenwich Mean Time	•	•	•	•	•	•	•	•	•	•	•	•
126	Vertical Deviation (VNAV)		•	•	•	•	•	•	•	•			
130	HIL								•		•	•	•
133	VIL								•		•	•	•
136	VFOM								•		•	•	•
140	UTC Time of Fix Fine								•		•	•	•
147	Magnetic Variation		•	•	•	•	•	•	•	•			
150	UTC Time of Fix From GPS								•		•	•	•
165	Vertical Velocity								•		•	•	•
166	North-South Velocity								•		•	•	•
173	Pseudo Localizer Deviation									•			
174	Pseudo Glideslope Deviation									•			
174	East-West Velocity								•		•	•	•
203	Pressure Altitude		•	•	•				•		•	•	•
221	Horizontal Command								•				
247	Horizontal Figure of Merit (HFOM)								•		•	•	•
251	Distance to Go	•	•	•	•	•	•	•	•	•			
252	Time to Go	•	•	•	•	•	•	•	•	•			
260	Date		•	•	•	•	•	•	•	•	•	•	•
261	GPS Discrete Word 1		•	•	•	•	•	•	•	•			
273	Operational Mode , Number of Satellites Tracked								•		•	•	•
275	LRN Status Word		•	•	•	•	•	•	•	•			
300	Station Declination, Type and Class		•	•	•	•	•	•	•	•			
303	Waypoint Header		•	•	•	•	•	•	•	•			
304	Waypoint ID #1 - #3		•	•	•	•	•	•	•	•			
305	Waypoint ID #4 - #6		•	•	•	•	•	•	•	•			
306	Waypoint Latitude		•	•	•	•	•	•	•	•			
307	Waypoint Longitude		•	•	•	•	•	•	•	•			
310	Present position Latitude	•	•	•	•	•	•	•	•	•			
311	Present position Longitude	•	•	•	•	•	•	•	•	•			
312	Ground Speed	•	•	•	•	•	•	•	•	•			
313	Track Angle	•	•	•	•	•	•	•	•	•			
314	True Heading	•	•	•	•	•	•	•	•	•			
315	Wind Speed	•	•	•	•	•	•	•	•	•			
316	Wind Angle	•	•	•	•	•	•	•	•	•			
320	Magnetic Heading	•	•	•	•	•	•	•	•	•			

Label #	Parameter Name	1	2	3	4	5	6	7	8	9	10	11	12
321	Drift Angle	•	•	•	•	•	•	•	•	•			
322	Flight Path Angle (VNAV)		•	•	•	•	•	•	•	•			
326	Lateral Scale Factor		•	•	•	•	•	•	•	•			
327	Vertical Scale Factor		•	•	•	•	•		•	•			
330	Conic Arc Inbound Course			•	•				•				
331	Conic Arc Radius			•	•				•				
332	Conic Arc Course Change Angle			•	•				•				
333	Airport Runway Azimuth			•	•				•				
334	Airport Runway Length			•	•				•				
335	Holding Pattern Azimuth			•	•				•				
340	Procedure Turn Azimuth			•	•				•				
350	Diagnostic								•				
351	Distance to Destination		•	•	•	•	•	•	•	•			
352	Estimated Time to Destination		•	•	•	•	•	•	•	•			
353	Software Version								•				
354	Configuration Data								•				
370	WGS-84 Altitude								•		•	•	•
371	Specific Equipment ID		•	•	•	•	•	•	•	•			
377	Equipment Hex ID Code	•	•	•	•	•	•	•	•	•	•	•	•

Table 65 GPS ARINC Output

6.1.9.2 VHF ARINC Output

N/A for IFD410, IFD510, IFD545, and Atlas FMS Only units

Label Number	Parameter Name
034G	VOR/ILS Frequency
035G	DME Frequency
100G	Selected Course # 1
173	Localizer Deviation
174	Glideslope Deviation
222	VOR Omni bearing
371G	Specific Equipment
377	Equipment Hex ID Code

Table 66 VHF ARINC Output

6.1.9.3 Onboard Radar ARINC Output

When configured, a Radar ARINC 429 channel shall transmit the following data:

Label Number	Parameter Name
270	Radar Mode, Tilt, and Gain
271	Roll-Trim, Range
273	Vertical Profile
Label Number	Parameter Name
275	Display Mode
324	Pitch angle (Degrees), Stabilization Not Supported
325	Roll Angle (Degrees), Stabilization Not Supported

Table 67 Radar ARINC Output

6.1.10 ARINC 453

Description	Connector	Pin	Signal Type
ARINC 453 RX +	P1050	40	Input
ARINC 453 RX -	P1050	41	Input

Table 68 ARINC 453 Input

6.1.11 RS170 Video

Description	Connector	Pin	Signal Type
RS170 Video In High	P1050	77	Input
RS170 Video In Low	P1050	78	Input

Table 69 RS170 Video Input

6.1.12 Com/VOR/ILS Audio Electrical Characteristics

Note: This section is N/A for IFD510/545/410

6.1.12.1 Com Microphone Key

Description	Connector	Pin	Signal Type
COM MIC Key	P1002	4	Input

Table 70 VHF Communication Microphone Key

This input is active if either the voltage to ground <1.9V or the resistance to ground is <375Ω. This input is considered inactive if the voltage to ground is 11-33 VDC.

Activating the COM MIC Key will cause the transmitter to transmit the audio on the COM MIC Audio HI.

6.1.12.2 Com Microphone Audio, INTERCOM Microphone Audio

Description	Connector	Pin	Signal Type
COM MIC Audio HI	P1002	6	Input
Description	Connector	Pin	Signal Type
COM MIC Audio LO	P1002	18	Input
INTERCOM MIC HI	P1002	5	Input
INTERCOM MIC LO	P1002	17	Input

Table 71 VHF Communication Audio
520Ω input impedance, supply 9V via 620Ω.

6.1.12.3 Com Audio, VOR/ILS Audio

Description	Connector	Pin	Signal Type
Com Audio HI	P1002	7	Output
Com Audio LO	P1002	19	Output
VOR/ILS Audio HI	P1006	16	Output
VOR/ILS Audio LO	P1006	17	Output

Table 72 VHF Communication and Navigation Audio Output

Each supply 65mW into 150Ω . They are balanced outputs and LO output must be connected.

6.1.12.4 Discrete Inputs

Description	Connector	Pin	Signal Type
Transmit Interlock (Unused)	P1002	14	Input
Com Remote Transfer	P1002	15	Input
VLOC Remote Transfer	P1006	28	Input
Com Remote Recall, Forward	P1001	74	Input
Com Remote Recall, Reverse	P1001	75	Input

Table 73 VHF Communication and Navigation Switch Inputs

This input is active if either the voltage to ground <1.9V or the resistance to ground is <375Ω. This input is considered inactive if the voltage to ground is 11-33 VDC.

COM Remote Transfer and VLOC Remote Transfer are momentary inputs. Momentarily depressing the VLOC or Com Remote transfer button toggles the active and #1 standby frequencies. Momentarily depressing the COM Remote Recall button inserts the next frequency in the Com preset list into the #1 standby slot.

6.1.12.5 Standby Com Monitor

Description	Connector	Pin	Signal Type
-------------	-----------	-----	-------------

Com Monitor Audio HI	P1006	7	Output
Com Monitor Audio LO	P1006	34	Output

Table 74 Standby Communication Output

This optional signal use can be used with audio panels that have a means of selecting the #1 standby com audio (e.g. Avidyne AMX240).

6.1.13 VOR/ILS Indicator Electrical Characteristics

Note: This section is N/A for IFD510/545/410 and Atlas FMS Only units.

6.1.13.1 Superflag

Description	Connector	Pin	Signal Type
VOR/LOC Superflag	P1006	15	Output
Glideslope Superflag	P1006	38	Output

Table 75 Navigation Superflag Output

The output supplies not less than 500 mA on a 28 volt system and 250 mA on a 14 volt system with the output voltage at (Aircraft voltage - 3VDC) when the flag is to be out of view. The output voltage with respect to ground is less than 3 VDC when the flag is to be in view. Power is from P1006 Pin 44

6.1.13.2 RMI/OBI Electrical Characteristics

Description	Connector	Pin	Signal Type
Main OBI Clock	P1001	43	Output
Main OBI Sync	P1001	45	Output
Main OBI Data	P1001	44	Output

Table 76 P1001 OBI Output

Description	Connector	Pin	Signal Type
VOR OBI Clock	P1006	25	Output
VOR OBI Sync	P1006	26	Output
VOR OBI Data	P1006	27	Output

Table 77 P1006 OBI Output

The output is active low.

6.1.14 DME Tuning

Note: This section is N/A for IFD510/545/410 and Atlas FMS Only units.

The IFD can channel a DME based on the tuned VLOC frequency. The IFD can be connected to a DME via 2x5, BCD, Slip parallel, or King Serial DME channeling format.

6.1.14.1 Serial/Parallel Tuning

Description	Connector	Pin	Signal Type
NAV PAR DME - 8MHz	P1006	14	Output
SER DME - CHAN REQ/PAR DME - 4MHz	P1006	20	Output*
Description	Connector	Pin	Signal Type
SER DME - RNAV MODE/PAR DME - 2MHz	P1006	21	Output*
NAV PAR DME - 1MHz	P1006	33	Output
NAV PAR DME - 800 kHz	P1006	37	Output
NAV PAR DME - 400 kHz	P1006	39	Output
NAV PAR DME - 200 kHz	P1006	40	Output
NAV PAR DME - 100 kHz	P1006	42	Output
NAV PAR DME - 50 kHz	P1006	43	Output
NAV DME COMMON	P1006	22	Input

Table 78 DME Serial/Parallel Output

* Used for 2x5 parallel DME tuning.

NAV DME Common must be pulled low for the IFD to channel the DME.

DME is active if the voltage to ground is <1.9 V or the resistance to ground is <375 Ω. Output is not more than 1.0V while sinking 20 mA.

6.1.14.2 King Serial DME Tuning

Description	Connector	Pin	Signal Type
NAV Serial DME - DATA	P1006	19	Output
NAV Serial DME - Clock	P1006	18	Output*
Serial DME - CHAN REQ/PAR DME - 4MHz	P1006	20	Output*
Serial DME - RNAV Mode/PAR DME - 2MHz	P1006	21	Output
NAV DME Common	P1006	22	Output

Table 79 DME Serial Tuning

* Output high is >8V when driving a 360Ω and < 10mV for a low.

NAV DME Common must be pulled low for the IFD to channel the DME. DME is active if the voltage to ground is <1.9 V or the resistance to ground is <375 Ω.

6.2 Bezel Lighting

The IFD can be connected to any of the following avionics lighting sources: 5/14/28VDC or 5 VAC. *Lighting bus inputs are not differential. Lighting bus low must be tied to ground. This dimming circuit is not compatible with circuits that vary to low side and keeps the lighting high side at bus voltage.* Dimming controls are described in Section 7.5.7.

6.3 Traffic System

The IFD can be connected to Traffic Systems either by RS232 or ARINC 429. The IFD supports the following Traffic Systems:

Manufacturer	Model	Data Format	Notes
Avidyne Corporation	TSA6XX, TAS6XXA, 9900BX	RS232 or ARINC 429	RS-232 preferred
Avidyne Corporation	Skytrax100 (formerly MLB100) (Navworx 200-0011-()-())	RS232 or ARINC 429	RS-232 preferred
Avidyne Corporation	Skytrax100B/SkyTrax200	RS232 or ARINC 429	RS-232 preferred
L3 Comm	SKY497, SKY899	ARINC 429	
Bendix/King	KTA-870, KMH880	ARINC 429	
Garmin	GTS800/820/850	ARINC 429	

Table 80 Traffic Systems

NOTE: These Traffic receiving devices are mutually exclusive. Multiple devices should not be installed/configured on a single unit. For those installations with a single IFD and more than one type of traffic source (e.g., "TAS600" and a TIS-B "SkyTrax100") in the aircraft, the display priority is TAS6XX/TCAD, Skywatch, Other ARINC429 Traffic sensor, SkyTrax100. Traffic from a lower priority source will not be displayed unless the higher priority source is switched off or failed.

6.4 Lightning Detection System

The IFD can be connected to Lightning Detection Systems via RS232. The IFD supports the following Lightning Detection Systems:

Manufacturer	Model	Data Format	Notes
Avidyne Corporation	TWX670	RS232	"Native" format
L3 Communications	WX500	RS232	WX500 must set both the 232 Input and 232 Output on the IFD.

Table 81 Lightning Detection System

6.5 Datalink Weather

The IFD can be connected to Datalink Weather Systems via RS232. The IFD supports the following Datalink Weather Systems.

Manufacturer	Model	Data Format	Notes
Avidyne Corporation	SkyTrax100(formerly MLB100) [Navworx 200-0011-()-()]	RS232	IFD with s/w 10.1.0 or later
	SkyTrax100(formerly MLB100) [Navworx 200-0011-()-()]	RS232	IFD with s/w 10.1.0 or later
	Skytrax 100B /SkyTrax200	RS232	IFD with s/w 10.1.0 or later
Freeflight Systems	FDL-978-RX	RS232	IFD with s/w 10.1.0 or later
Heads-up Technologies	XMD-076	RS232	IFD with s/w 10.2.3.1 or later
Garmin	GDL69/69A P/N 011-00986-00 or 011-00987-00 only Pre-Software 10.2.3.1 With Software 10.2.3.1 or later P/N 011-03177-X0 will also work	RS232	Garmin Software version 4.01 or later for first generation GDL's
	GDL 88	RS232	

Table 82 Weather Datalink

6.6 Audio Panels

The IFD can be connected to various Audio Panels via analog connections. The IFD supports the following Audio Panels:

Manufacturer	Model	Data Format	Notes
--------------	-------	-------------	-------

Avidyne	AMX240	Analog Audio	
Garmin	SL10/ SL10MS/ SL10M/ SL10S/ SL15/ SL15M/ GMA340/ GMA347	Analog Audio	
Honeywell (Bendix/King)	KMA24/ KMA24H-70/71 KMA26/ KMA28	Analog Audio	
PS Engineering	PMA6000/ PMA 7000 Series/ PMA 8000 Series	Analog Audio	

Table 83 Audio Panels

6.7 GAD 42

The IFD can be connected to the Garmin GAD42 Interface Adapter.

If the IFD is replacing a GNS530/W or GNS430/W that had previously been connected to a GAD42, then no action is required since the configuration is already saved in the GAD42.

If this is a new installation of an IFD (i.e. not replacing an existing GNS-530/W or GNS-430/W) or if the GAD42 had to be replaced for service, then the GAD42 must be configured via a manual strapping method as described in Garmin P/N 190-00159-00 GAD42 Installation Manual, Section 5.1.

6.8 Air Data System Sources

The IFD can be connected to either Uncorrected or Baro-corrected Altitude Sources. The IFD can be connected to the following Air Data Systems:

Manufacturer	Model	Data Format	Notes
Aspen	EFD1000	ARINC 429	Low Speed
Avidyne	Entegra PFD	ARINC 429	Low Speed
Garmin	G500/600	ARINC 429	Low Speed
B & D	90004-003	ARINC 429	Low Speed
Honeywell (Bendix/King)	KDC281/481	ARINC 429	Low Speed
Insight	TAS 1000	RS232	
Shadin	ADC-2000	RS232	

Table 84 Air Data Systems

6.8.1.1 Uncorrected Pressure Altitude Sources

The IFD can accept uncorrected altitude from multiple sources in the following formats: ARINC 429, RS232, or a Gray Code altitude encoder. If multiple altitude sources are connected, the IFD will use the altitude sources in this order (highest first):

1. ARINC 429 ADC
2. ARINC 429 EFIS
3. ARINC 429 Traffic Advisory System
4. RS232 FADC
5. RS-232 Altitude Encoder
6. Parallel Altitude Encoder (Gray Code)

6.8.1.2 Baro-corrected Altitude Sources

The IFD can accept baro-corrected altitude from multiple sources. The IFD can accept Altitude information from altitude Air Data Systems in the following formats: ARINC 429 or RS232. If multiple altitude sources are connected to the IFD, the IFD will use the altitude sources in this order (highest first):

1. ARINC 429 INS/IRU
2. ARINC 429 EFIS
3. ARINC from Transponder
4. RS232 FADC

6.8.1.3 Other Air Data Sources

The IFD can be connected to Air Data Systems that transmit the following labels via ARINC 429 if all the following is true:

- The Air Data Computer provides the following labels:
 - 203 - Pressure Altitude
 - 204 - Barometric- Corrected Altitude
 - 210 - True Airspeed
 - 211 - Total Air Temperature
 - 213 - Static Air Temperature
- The Air Data source is TSO approved and has a separate installation approval
- All wiring must be installed per the Air Data Computer's installation data

6.9 Heading System Sources

The IFD can accept Heading data from multiple sources. The IFD can accept heading information from Heading Systems in the following formats: ARINC 429 or RS232. If multiple heading sources are connected to the IFD, the IFD will use the heading sources in this order (highest first):

1. ARINC 429 INS/IRU
2. ARINC 429 EFIS
3. ARINC 429 from GAD42
4. ARINC 429 from EHSI
5. ARINC 429 from GTX 33/330
6. ARINC 429 Traffic Advisory System
7. Synchro Heading (N/A for IFD510/545/410 and Atlas FMS Only units)
8. RS232 FADC
9. RS232 Lightning Detection System (The WX500 can only be used as a heading source if it is configured for a Synchro output.)

The IFD5XX/Atlas can be connected to the following IRU/AHRS systems:

Manufacturer	Model	Data Format	Notes
Collins	AHS-85E	ARINC 429	High Speed

Table 85 IRU/AHRS Systems

The Avidyne IFD can accept heading information via ARINC 429 from other IRU/AHRS sources if the following labels are provided:

- 314 - True Heading
- 320 - Magnetic Heading

IRU/AHRS not listed in the table above can still be approved if the following conditions are met:

- The IRU/AHRS provides ARINC 429 labels 314 and/or 320.
- The IRU/AHRS installation is previously FAA approved.
- The IFD must be installed per Section 4.5.1.
- The IFD must pass the ground test in Section 7.6.16 before returning aircraft to service

6.10 Multifunction Displays

The IFD can be connected to Multifunction Display Systems via RS232 or ARINC 429. The IFD supports the following Multifunction Display Systems:

Manufacturer	Model	Data Format	Notes
Garmin	MX20	RS232	<ul style="list-style-type: none"> • Aviation No Alt format for MX20 version 5.5 and earlier • Aviation format for MX20 version 5.6 and later.
Garmin	GMX200	RS232	1. Aviation format for all GMX200 versions
Avidyne Corporation	EX500/EX600/EX5000	ARINC 429	<ul style="list-style-type: none"> • Use GAMA format 2, low speed • MFD software P/N 530-00193-() or later is required
Avidyne Corporation	FlightMax FSD Series	RS232	<ul style="list-style-type: none"> • GAMA output may also be used. However, flight plans with an Arc will be displayed as a gap.

Table 86 Multifunction Display

6.11 Forward Looking Terrain Alerting

This section will describe the external interfaces for the FLTA interface. FLTA does provide aural alerting to the pilot of projected terrain (ground and obstacle) conflicts. FLTA also has the ability to command the various TAWS remote annunciators to light up as appropriate. Section 7.5.4 has instructions for turning FLTA on or off.

6.11.1 Audio

Pin Name	Connector	Pin	I/O
Audio 1 HI	P1001	37	Output
Audio 1 LO	P1001	38	Output
Audio 2 HI	P1001	52	Output
Audio 2 LO	P1001	53	Output

Table 87 Terrain Awareness Audio Output

The audio output 1 is a low impedance output. 100mW at 500-ohm.
 The audio output 2 has an output impedance of 240-ohm and is capable of driving 100mW into a 500-ohm load.

6.11.2 Annunciators

Pin Name	Connector	Pin	I/O
----------	-----------	-----	-----

Terrain not available annunciate	P1050	9	Output
Terrain Warning Annunciate	P1050	10	Output
Terrain Caution Annunciate	P1050	11	Output
TAWS Inhibit Annunciate	P1050	12	Output

Table 88 Terrain Awareness Annunciator Output

6.12 Fixed Wing TAWS Unlock

IFD 5xx and Atlas units with software release 10.3.0.2 or later contain TSO-C151()-compliant TAWS functionality via an unlock enablement. When enabled it may be used to satisfy the 14 CFR 91.223 TAWS requirement on those airplanes where it applies.

Note: Fixed wing TAWS is not available for IFD 4xx units.

6.12.1 Fixed Wing TAWS Audio

IFD/Atlas units with the TAWS unlock enabled are **required** to have the TAWS Audio Outputs wired to the #1 unswitched input of the audio panel. Approved interface can be found in Figure D-26

Pin Name	Connector	Pin	I/O
Audio 1 HI	P1001	37	Output
Audio 1 LO	P1001	38	Output
Audio 2 HI	P1001	52	Output
Audio 2 LO	P1001	53	Output

The audio output 1 is a low impedance output. 100mW at 500-ohm.

The audio output 2 has an output impedance of 240-ohm and is capable of driving 100mW into a 500-ohm load.

6.12.2 Fixed Wing TAWS Annunciators

For IFD's with the TAWS Unlock enabled which do not meet the field of view requirements listed in section 5.1, an external TAWS annunciator will be **required**. The installation of the external annunciator must meet the field of view requirements in section 5.1.

Pin Name	Connector	Pin	I/O
Terrain not available annunciate	P1050	9	Output
Terrain Warning Annunciate	P1050	10	Output
Terrain Caution Annunciate	P1050	11	Output
TAWS Inhibit Annunciate	P1050	12	Output

6.13 External TAWS/EGPWS Output

The IFD does not accept any data for use or display from any externally connected TAWS or EGPWS system.

NOTE: Use of an externally attached TAWS/EGPWS system will disable the systems built-in TAWS capability.

The IFD is capable of sending position data to the following EGPWS systems:

Manufacturer	Model	Notes
Honeywell	KGP560, KGP860	Serial GPS position output only
Honeywell	MK V, MK VI, MK VII, MK VIII, MKV-A, MK XXI, MK XXII	Serial GPS position output only

Table 89 TAWS/EGPWS Output

6.14 ADS-B Transponder/UAT Output

The IFD will transmit ADS-B GPS position data to the following compatible ADS-B capable transponders/UAT. The ADS-B out transmitters listed in the Table below have been tested with Avidyne IFD GPS receivers (GPS position source(s)) and have been found to be compliant combinations to meet all ADS-B out requirements compliant with 14 CFR 91.217.

Manufacturer	Model	Notes
Avidyne Trig	AXP340 TT31	<ul style="list-style-type: none"> • ADS-B output requires a separate installation approval. See Avidyne AXP322/ AXP340 AML STC SA00352BO • For ADS-B out compliance, a squat switch is required for automatically selecting the transponder air or ground mode of operation. For aircraft without a squat switch, connect the squat switch input of the transponder to P1001 pin 8 of one of the IFD. Set the transponder to accept an active low when performing that squat switch setup. • The IFD retransmits the Altitude data received from external altitude devices to AXP340. This is a non-TSO function of the IFD and must be tested and approved by the installer prior to returning the aircraft to service. The IFD will use the airdata source with the highest priority, reference Section 6.8.1.1. Installers must ensure the airdata source being used for transponder Mode C transmissions complies with 14 CFR 91.217. After installation, the transponder system must be tested per 14 CFR 91.411 to verify the airdata retransmitted by IFD is operating correctly prior to return to service. The Hardware and Software Design Assurance for the Altitude Retransmission is Level B and C respectively. The IFD has a maximum internal latency of 340 mS for retransmission the altitude data. <ul style="list-style-type: none"> • See Appendix D for AXP340 interconnect.
Avidyne Trig	AXP322 TT22	<ul style="list-style-type: none"> • ADS-B output requires a separate installation approval. See Avidyne AXP322/ AXP340 AML STC SA00352BO.

Manufacturer	Model	Notes
Bendix King	KXP80	<ul style="list-style-type: none"> • For ADS-B out compliance, a squat switch is required for automatically selecting the transponder air or ground mode of operation. For aircraft without a squat switch, connect the squat switch input of the transponder to P1001 pin 8 of one of the IFD. In either case, set the transponder to “Avidyne” when performing the squat switch setup. See section 7.5.13 • The IFD retransmits the Altitude data received from external altitude devices to AXP322. This is a non-TSO function of the IFD and must be tested and approved by the installer prior to returning the aircraft to service. The IFD will use the airdata source with the highest priority, reference Section 6.8.1.1. Installers must ensure the airdata source being used for transponder Mode C transmissions complies with 14 CFR 91.217. After installation, the transponder system must be tested per 14 CFR 91.411 to verify the airdata retransmitted by IFD is operating correctly prior to return to service. The Hardware and Software Design Assurance for the Altitude Retransmission is Level B and C respectively. The IFD has a maximum internal latency of 340 mS for retransmission the altitude data. • See Appendix D for AXP322 interconnect. • IFD must have software 10.1.0 or later
Garmin	GTX330ES	<ul style="list-style-type: none"> • The IFDXXX AML STCs IFDXXX SA00343BO & IFD5XX/ Atlas ST00411BO approves ADS-B out capability for this ADS-B OUT transmitter and GNSS position sensor combination to comply with 91.227. • For ADS-B out compliance, a squat switch is required for automatically selecting the transponder air or ground mode of operation. For aircraft without a squat switch, connect the squat switch input of the transponder to P1001 pin 8 of one of the IFD. Set the transponder to accept an active low when performing that squat switch setup. • The IFD retransmits the Altitude data received from external altitude devices to GTX330ES. This is a non-TSO function of the IFD and must be tested and approved by the installer prior to returning the aircraft to service. The IFD will use the airdata source with the highest priority, reference Section 6.8.1.1. Installers must ensure the airdata source being used for transponder Mode C transmissions complies with 14 CFR 91.217. After installation, the transponder system must be tested per 14 CFR 91.411 to verify the airdata retransmitted by IFD is operating correctly prior to return to service. The Hardware and Software Design Assurance for the Altitude Retransmission is Level B and C respectively.

Manufacturer	Model	Notes
		<p>The IFD has a maximum internal latency of 340 mS for retransmission the altitude data.</p> <ul style="list-style-type: none"> • See Appendix D for GTX330ES interconnect. • IFD must have software 10.2 or later
Garmin	GTX335 GTX345	<ul style="list-style-type: none"> • The IFD AML STCs IFDXXX SA00343BO & IFD5XX/Atlas ST00411BO approves ADS-B out capability for this ADS-B OUT transmitter and GNSS position sensor combination to comply with 91.227. • For ADS-B out compliance, a squat switch is required for automatically selecting the transponder air or ground mode of operation. For aircraft without a squat switch, connect the squat switch input of the transponder to P1001 pin 8 of one of the IFD. Set the transponder to accept an active low when performing that squat switch setup. • The IFD retransmits the Altitude data received from external altitude devices to GTX3X5. This is a non-TSO function of the IFD and must be tested and approved by the installer prior to returning the aircraft to service. The IFD will use the airdata source with the highest priority, reference Section 6.8.1.1. Installers must ensure the airdata source being used for transponder Mode C transmissions complies with 14 CFR 91.217. After installation, the transponder system must be tested per 14 CFR 91.411 to verify the airdata retransmitted by IFD is operating correctly prior to return to service. The Hardware and Software Design Assurance for the Altitude Retransmission is Level B and C respectively. The IFD has a maximum internal latency of 340 mS for retransmission the altitude data. • See Appendix D for GTX3X5 interconnect. • IFD must have software 10.2 or later
Garmin	GTX3000	<ul style="list-style-type: none"> • The IFD AML STCs IFDXXX SA00343BO & IFD5XX/Atlas ST00411BO approves ADS-B out capability for this ADS-B OUT transmitter and GNSS position sensor combination to comply with 91.227. • For ADS-B out compliance, a squat switch is required for automatically selecting the transponder air or ground mode of operation. For aircraft without a squat switch, connect the squat switch input of the transponder to P1001 pin 8 of one of the IFD. Set the transponder to accept an active low when performing that squat switch setup. • The IFD retransmits the Altitude data received from external altitude devices to GTX3000. This is a non-TSO function of the IFD and must be tested and approved by the installer prior to returning the aircraft to service. The IFD will use the airdata source with the highest priority,

Manufacturer	Model	Notes
		<p>reference Section 6.8.1.1. Installers must ensure the airdata source being used for transponder Mode C transmissions complies with 14 CFR 91.217. After installation, the transponder system must be tested per 14 CFR 91.411 to verify the airdata retransmitted by IFD is operating correctly prior to return to service.</p> <ul style="list-style-type: none"> • The Hardware and Software Design Assurance for the Altitude Retransmission is Level B and C respectively. • The IFD has a maximum internal latency of 340 mS for retransmission the altitude data. • See Appendix D for GTX3000 interconnect. • IFD must have software 10.2 or later
Becker	BXT-65XX	<ul style="list-style-type: none"> • The IFD AML STCs IFDXXX SA00343BO & IFD5XX/Atlas ST00411BO approves ADS-B out capability for this ADS-B OUT transmitter and GNSS position sensor combination to comply with 91.227. • For ADS-B out compliance, a squat switch is required for automatically selecting the transponder air or ground mode of operation. For aircraft without a squat switch, connect the squat switch input of the transponder to P1001 pin 8 of one of the IFD. Set the transponder to accept an active low when performing that squat switch setup. • The IFD retransmits the Altitude data received from external altitude devices to BXT-65XX. This is a non-TSO function of the IFD and must be tested and approved by the installer prior to returning the aircraft to service. The IFD will use the airdata source with the highest priority, reference Section 6.8.1.1. Installers must ensure the airdata source being used for transponder Mode C transmissions complies with 14 CFR 91.217. After installation, the transponder system must be tested per 14 CFR 91.411 to verify the airdata retransmitted by IFD is operating correctly prior to return to service. <p>The Hardware and Software Design Assurance for the Altitude Retransmission is Level B and C respectively.</p> <p>The IFD has a maximum internal latency of 340 mS for retransmission the altitude data.</p> <ul style="list-style-type: none"> • See Appendix D for BXT655XX interconnect. • IFD must have software 10.2 or later
L-3 Avionics	NGT9000R NGT9000R+ NGT9000RD NGT9000RD+	<ul style="list-style-type: none"> • ADS-B output using internal GPS requires a separate installation approval. This system utilizes an internal position source for ADS-B out compliance. See L3 STC. • NGT9000 may use IFD series GPS as a position source based on Avidyne part 23 AML STC. • For ADS-B out compliance, a squat switch is required for automatically selecting the transponder air or ground

Manufacturer	Model	Notes
		<p>mode of operation. For aircraft without a squat switch, connect the squat switch input of the transponder to P1001 pin 8 of the controlling IFD with software 10.0.0 or higher. Set the transponder to accept an active low on ground when performing that squat switch setup.</p> <ul style="list-style-type: none"> • The NGT9000XX needs a pressure altitude input • See Appendix D for NGT9000 interconnect. • IFD must have software 10.2.3.1 or later for the control logic
<p>ACSS L-3 Avionics Bendix/King</p>	<p>NXT-700</p>	<ul style="list-style-type: none"> • ADS-B output requires a separate installation approval. This system utilizes an internal position source for ADS-B out compliance. See L3 STC. • For ADS-B out compliance, a squat switch is required for automatically selecting the transponder air or ground mode of operation. For aircraft without a squat switch, connect the squat switch input of the transponder to P1001 pin 8 of the controlling IFD for IFD's with software 10.0.0 or higher. Set the transponder to accept an active low on ground when performing that squat switch setup. • The NXT-700 needs a pressure altitude input • The NXT-700 has its own internal GPS receiver • See Appendix D for NXT-700 interconnect • IFD must have software 10.2.3.1 or later for the control logic
<p>Bendix/King</p>	<p>KT74</p>	<ul style="list-style-type: none"> • The IFD AML STCs IFDXXX SA00343BO & IFD5XX/Atlas ST00411BO approves ADS-B out capability for this ADS-B OUT transmitter and GNSS position sensor combination to comply with 91.227. • For ADS-B out compliance, a squat switch is required for automatically selecting the transponder air or ground mode of operation. For aircraft without a squat switch, connect the squat switch input of the transponder to P1001 pin 8 of one of the IFD. Set the transponder to accept an active low when performing that squat switch setup. • The IFD retransmits the Altitude data received from external altitude devices to KT74. This is a non-TSO function of the IFD and must be tested and approved by the installer prior to returning the aircraft to service. The IFD will use the airdata source with the highest priority, reference Section 6.8.1.1. Installers must ensure the airdata source being used for transponder Mode C transmissions complies with 14 CFR 91.217. After installation, the transponder system must be tested per 14 CFR 91.411 to verify the airdata retransmitted by IFD is operating correctly prior to return to service. <p>The Hardware and Software Design Assurance for the</p>

Manufacturer	Model	Notes
		<p>Altitude Retransmission is Level B and C respectively. The IFD has a maximum internal latency of 340 mS for retransmission the altitude data.</p> <ul style="list-style-type: none"> • See Appendix D for KT74 interconnect. • IFD must have software 10.2.3.1 or later
Bendix/King	MST-70B	<ul style="list-style-type: none"> • The IFD AML STCs IFDXXX SA00343BO & IFD5XX/Atlas ST00411BO approves ADS-B out capability for this ADS-B OUT transmitter and GNSS position sensor combination to comply with 91.227. • For ADS-B out compliance, a squat switch is required for automatically selecting the transponder air or ground mode of operation. For aircraft without a squat switch, connect the squat switch input of the transponder to P1001 pin 8 of one of the IFD. Set the transponder to accept an active low when performing that squat switch setup. • The IFD retransmits the Altitude data received from external altitude devices to MST-70B. This is a non-TSO function of the IFD and must be tested and approved by the installer prior to returning the aircraft to service. The IFD will use the airdata source with the highest priority, reference Section 6.8.1.1. Installers must ensure the airdata source being used for transponder Mode C transmissions complies with 14 CFR 91.217. After installation, the transponder system must be tested per 14 CFR 91.411 to verify the airdata retransmitted by IFD is operating correctly prior to return to service. <p>The Hardware and Software Design Assurance for the Altitude Retransmission is Level B and C respectively. The IFD has a maximum internal latency of 340 mS for retransmission the altitude data.</p> <ul style="list-style-type: none"> • See Appendix D for MST-70B interconnect. • IFD must have software 10.2.3.1 or later
Rockwell Collins	TDR94 TDR94D	<ul style="list-style-type: none"> • The IFD AML STCs IFDXXX SA00343BO & IFD5XX/Atlas ST00411BO approves ADS-B out capability for this ADS-B OUT transmitter and GNSS position sensor combination to comply with 91.227. • For ADS-B out compliance, a squat switch is required for automatically selecting the transponder air or ground mode of operation. For aircraft without a squat switch, connect the squat switch input of the transponder to P1001 pin 8 of one of the IFD. Set the transponder to accept an active low when performing that squat switch setup. • The IFD retransmits the Altitude data received from external altitude devices to TDR94. This is a non-TSO function of the IFD and must be tested and approved by the installer prior to returning the aircraft to service. The IFD will use the airdata source with the highest priority,

Manufacturer	Model	Notes
		<p>reference Section 6.8.1.1. Installers must ensure the airdata source being used for transponder Mode C transmissions complies with 14 CFR 91.217. After installation, the transponder system must be tested per 14 CFR 91.411 to verify the airdata retransmitted by IFD is operating correctly prior to return to service.</p> <p>The Hardware and Software Design Assurance for the Altitude Retransmission is Level B and C respectively.</p> <p>The IFD has a maximum internal latency of 340 mS for retransmission the altitude data.</p> <ul style="list-style-type: none"> • See Appendix D for TDR94 interconnect. • The TDR94 part number needs to be a -500 or higher for ADS-B OUT to be approved. • IFD must have software 10.2.3.1 or later

Table 90 ADS-B Output

6.15 Autopilot

The IFD can be connected to various Autopilot Systems via analog or ARINC 429 connections. The IFD supports the following Autopilot Systems:

Manufacturer	Model	Data Format	Notes
Avidyne	DFC90	Serial	Avidyne and Aspen PFDs
Honeywell (Bendix/King)	KAP100/140/150, KFC150/200/250/275 /300/325 KCP 320	Analog Deviation, Discrete	
	KFC225	Analog Deviation, Discrete, ARINC 429 GPSS	Dual IFD installations require only the IFD connected to the autopilot be setup for Prompt (See section 7.5.5)
	KFC400	ARINC 429	
Century	I/II/III/IV, 21/31/41, 2000, Trident	Analog Deviation, Discrete	
	AK 1081	ARINC 429 GPSS	
S-TEC (Cobham)	System 20/30/40/50/ 55/61/62/GPSS/65	Analog Deviation, Discrete	
	System 55X	Analog Deviation, Discrete, ARINC 429 GPSS	
	ST-901	ARINC 429 GPSS	
Collins	APS 65 ()	Analog Deviation, Discrete	
	APS 3000	ARINC 429	Requires Software 10.2.2 or higher

Table 91 Autopilot Systems

6.16 Video Input

The IFD5XX and Atlas can be connected to the following RS-170 video sources:

Manufacturer	Model	Data Format	Notes
Various	FAA Approved	RS-170	Some cameras require mod 21. Contact Avidyne Tech Support with make and model of the camera to determine if mod 21 is required.

Table 92 Video Systems

6.17 Radar Display and Control

The IFD can be connected to the following radar system:

Manufacturer	Model	Data Format	Notes
Honeywell (Bendix/King)	RDR2000, RDR2060, RDR2100, RDS-8X	ARINC 429 (out) ARINC 453 (in)	Only the IFD5XX and Atlas can control and display radar. SW release 10.2.4.1 or greater is required.

Table 93 Radar Systems

7. Configuration and Checkout

After completing installation, a complete installation checkout should be performed. Complete the following sections to verify the installation is installed correctly. Prior to configuring the IFD unit, the following checks should be performed.

7.1 Wiring Check

Verify wiring is properly installed and secured. Verify the wiring does not interfere with the flight controls. Verify all wiring connected to IFD is connected correctly to the unit. **Caution:** Failure to properly connect aircraft wiring to the IFD may result in damage to the IFD or to the equipment connected to the IFD.

7.2 Mounting Check

Verify the IFD5XX/IFD4XX tray is securely installed to the airframe.

For Atlas units, verify all Dzus fasteners are fully latched and the Atlas is securely mounted to the Dzus rails.

7.3 Chassis ID Setting

For dual IFD installations, it is imperative that the proper Chassis ID settings are established for each IFD via dip switches located along the right side of the IFD outer chassis. Not doing so will result in multiple error messages and degraded performance when two or more IFDs are installed in an airplane.

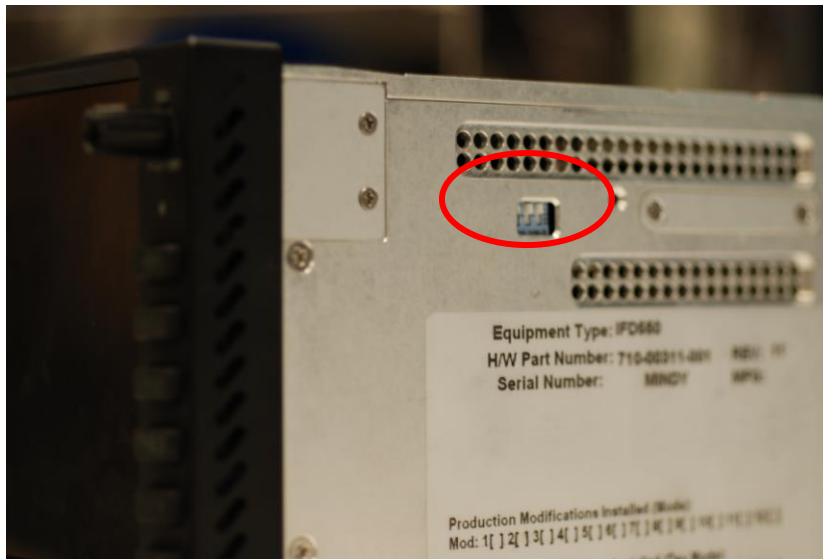

Figure 11 IFD DIP Switches

At installation time, determine which IFD is to be designated as IFD #1 and which is to be designated as IFD #2 (Note, there is no operational difference, This is a Databus address assignment necessity). Set the side chassis ID dip switches per the table below:

IFD Position Designation	DIP switch selections
IFD #1	↑ ↑ ↑ (up, up, up)
IFD #2	↓ ↑ ↑ (down, up, up)

Table 94 DIP Switch Configuration

7.4 Unit Installation

Install IFD5XX/IFD4XX unit in the tray using the captive 3/32” Hex screw. Verify the connectors are fully engaged prior to powering on the unit.

Install the Atlas in the Dzus rail using an appropriately sized flat blade tool after verifying the connectors are latched.

7.5 Configuration

The IFD can be configured in the aircraft. This section will describe the procedures for configuring the IFD.

Configuration consists of setting up communication protocols in Maintenance Mode, designating specific types of equipment to be integrated and setting up system settings.

Configuration also consists of setting up User Options preferences in non-Maintenance Mode via the SYS tab of the AUX page.

For new installations, use this section to configure the IFD for the specific airplane.

For replacement installations in which the IFD5XX/4XX is replacing a GNS 530/W or GNS 430/W, use Appendix F: Configuration Setup of this manual to first record the configuration of the GNS530/W or GNS430/W that is being replaced by the IFD and then using that recorded data, use the IFD Maintenance Mode pages as defined in this section and Appendix F: Configuration Setup to properly set up and record configurations.

7.5.1 Maintenance Mode

The Maintenance Mode can be accessed by using the following procedures (on the ground only):

1. Power on the IFD
2. Acknowledge all start up screens by pressing “Enter”
3. Press Proceed Line Select Key (LSK) followed by the Confirm LSK on the database acknowledgement screen (if shown)
4. Select the “AUX” function key to display the Auxiliary Page. Press on the right side of the “AUX” Function key until the “SYS” tab is shown
5. Select “Status/Software” LSK by pressing associated button until “Update Databases” appears. (If shown)
6. Select “Update Databases” LSK by pressing the associated button. Press the “Confirm” LSK after it appears. The screen will blank for several seconds before coming up in Maintenance Mode



Please note: Screen Page numbers shown below may not match unit.

7.5.2 Password PIN Page

7.5.2.1 Enabling or ignoring the password protection feature

A new feature with release 10.2.4.1 or greater is the ability to protect the configuration pages in maintenance mode with a PIN number. On page 1 of the config tab, you will see “Password Protection PIN” as shown in the picture below. Entering a 4-digit PIN on this page IS NOT REQUIRED. If you do not want to protect the configuration settings do not enter a PIN and simply move on to the remaining configuration pages. If you do enter a PIN make sure that you save it because once the configuration pages are set up, they cannot be changed without first entering the PIN number.

7.5.2.2 Password protection PIN Page

If you have chosen to enter a PIN on page 1 of the Config tab you will see the PIN number in the Enter PIN text box and directly below you will see “Current PIN: followed by the PIN number entered. See the picture below. Once the PIN is entered continue configuring the remaining pages and after exiting maintenance mode the configurations cannot be changed without first entering the PIN.

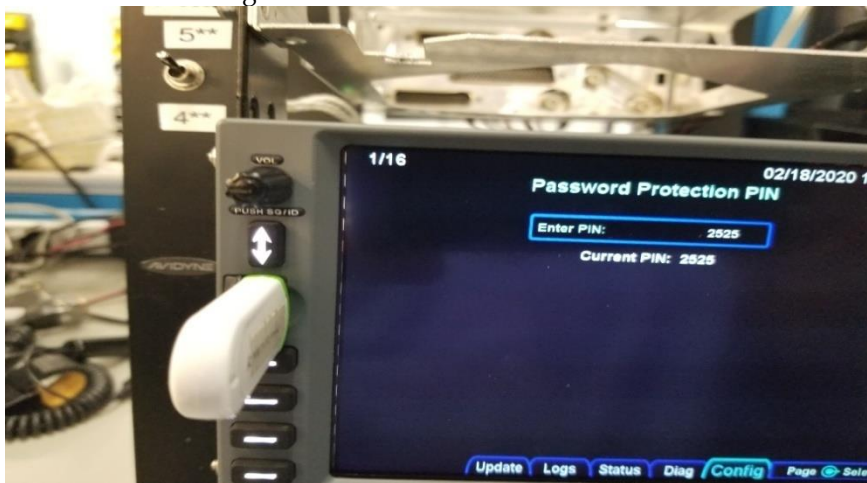

7.5.2.3 Forgotten PIN

If you are making changes to the Config pages that are PIN protected and have not entered the correct PIN prior to making the changes you will see the title of the Config page and directly underneath the title in yellow lettering “PASSWORD-PROTECTED” see the picture below. If you see this none of the changes you make will be retained. If you have forgotten the PIN or do not know the PIN contact Avidyne Technical Support at techsupport@avidyne.com and a .dsf file will be sent to you to clear the PIN.

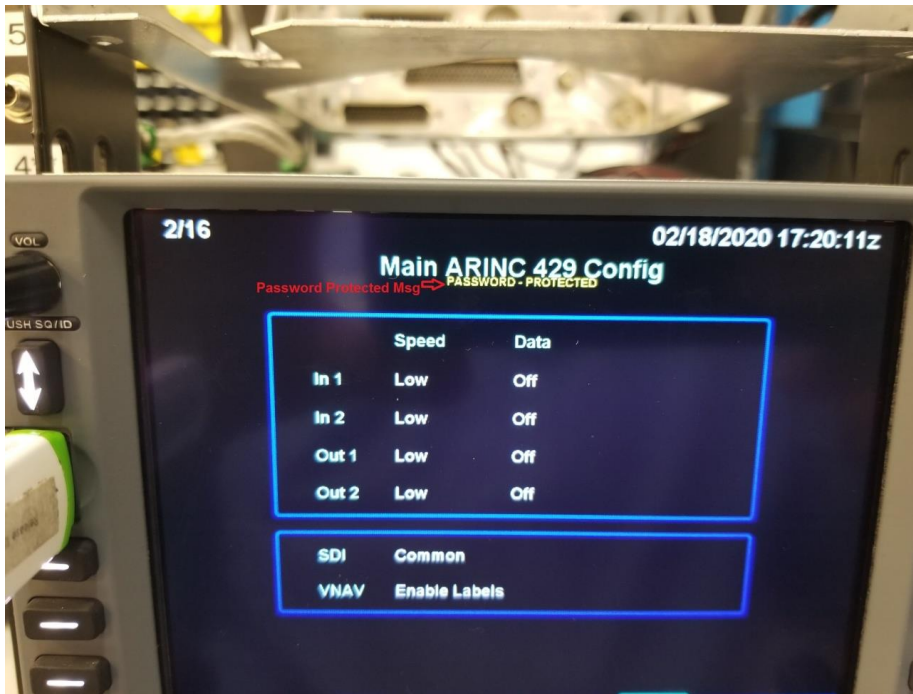

7.5.3 ARINC 429 Port Configuration 

The ARINC 429 can be selected individually for each ARINC 429 Transmit and Receive Port. Each Transmit and Receive Port will have a “Speed” selection and “Data” selection.



Figure 12 IFD4XX ARINC 429 Configuration Page

Note: Shown is the IFD4XX ARINC 429 Config Page. The IFD5XX and Atlas Config Page has an OUT 1 and OUT 2.
 IFD5XX and Atlas have OUT 2 with 5 settings - Off, ARINC 743A, ARINC 743A+, Onboard Radar, and Becker BXT Ctl

The “Speed” Selection will have the following options:

Selection	Description
Low	Standard low-speed ARINC 429 (nominally 12.5 Kb per second)
High	High-speed ARINC 429 (nominally 100Kb per second)

Table 95 ARINC 429 Speed Selection

The "Data" will have the following INPUT options:

Selection	Description
Off	No device connected to this ARINC 429 input
Airdata	Altitude, temperature, and speed information from the following Air Data Systems: B&D 2600, 2601, 2800, 90004-003, Bendix/King KAD 280/480, Shadin ADC 2000
Airdata/AHRS	Heading, altitude, temperature, and speed information from an Air Data/AHRS system.
EFIS	Selected course, heading, and joystick waypoint information from a EFIS system. Certain versions of the Collins and Honeywell EFIS may be compatible with this format.
EFIS/Airdata	Selected course, heading, joystick waypoint, altitude, temperature, and speed information.
Flight Control	Selected course information from the following Flight Control systems: Bendix/King KFC400
Garmin GAD 42	Selected course, heading, and true airspeed data from Garmin GAD 42.
Garmin GDL 88 Traffic	Garmin GDL 88 Traffic from the GDL 88/GTX 345 This ARINC 429 speed should be set to the high speed.
Garmin GDL 88 Traffic W/TCAS	Garmin GDL 88 with a Garmin GTS 800/820/825 or a L-3 SKY497/SKY 899 System Unsupported, reserved for future use This ARINC 429 speed should be set to the high speed.
Garmin GDL 88 Traffic W/TCAD	Garmin GDL 88 with a Avidyne TAS6XX or Ryan 9900BX System This ARINC 429 speed should be set to the high speed.
Garmin GDU	Selected course, heading, altitude, temperature and speed information from the following systems: Garmin GDU (G500/G600/GI-275)
Garmin GTX 330	Garmin GTX330 (No TIS) This ARINC 429 speed should be set to the high speed.
Garmin GTX 330 w/Traffic	Garmin GTX 330 w/TIS This ARINC 429 speed should be set to the high speed.
Honeywell EFIS	Selected course, heading, and joystick waypoint information from the following EFIS systems:

Selection	Description
	Aspen EFD1000 (If connected to an ACU1, set the ARINC 429 speed to low speed. If connected to an ACU2 and using ADF, RADALT or Remote OAT data set the ARINC 429 speed to high speed, otherwise low speed.) Honeywell Primus 1000 Avidyne EXP5000*
INS/IRU	Heading information from the following Inertial systems: Bendix/King KAH 460 Collins AHC 85 Honeywell Laseref Litef LTR 81 Litton LTN 90-100, LTN 91, LTN 92
RADAR Graphics	Joystick waypoint information from a RADAR graphics unit
Radar Altimeter	Rockwell Collins ALT 1000/4000 Garmin GRA 55/5500 FreeFlight 4000/4500 Honeywell RT 300 BK KRA-10A
Sandel EHSI	Selected course and heading information from the following EHSI systems: Sandel SN 3308 Sandel SN 3500 Avidyne EXP5000*
Traffic Advisory	Traffic information from the following traffic advisory systems: Bendix/King KTA-870, KMH880 Garmin GTS 800/820/850 Garmin GDL 88 Avidyne TAS6XX (but RS-232 is preferred) Ryan 9900BX (but RS-232 is preferred) L3 Communications SKY497 SkyWatch L3 Communications SKY899 SkyWatch HP
MLB 100 Traffic	Avidyne SkyTrax100/SkyTrax200/MLB100 or Freeflight FDL-978-RX Traffic (But RS232 is preferred)
Becker BXT	Becker BXT 65XX Transponder Display This ARINC 429 speed should be set to the low speed.

Selection	Description
Thales EFIS	Used when connected to a Thales FlytX system

Table 96 ARINC 429 Input Selection

*Honeywell EFIS selection is preferred as it has more label information

Note: Only ARINC 429 Traffic is shared between IFDs on the CrossSync line, all other ARINC 429 devices may be wired to both IFDs in dual IFD installations since ARINC 429 data is generally not shared between IFDs via the CrossSync line.

The “Data” will have the following OUTPUT options:

Selection	Description
Off	No device(s) connected to ARINC 429 output
ARINC 429	Standard ARINC 429 output (non-GAMA)
GAMA 429	ARINC data as define by the General Aviation Manufacturers’ Association (GAMA) General Aviation Subset, 2 nd Edition. The output data includes navigation, flight plan information to the following systems: Garmin GAD 42 Interface Adapter Collins EFIS 84 (select “Non-WAAS” on the IFD) Bendix/King EFS 40/50 with update SW15/01 (GPS vertical guidance provided on EFIS) Certain other versions of Collins EFIS may also be compatible with this format.
GAMA 429 Bendix King	ARINC 429 data as defined by the GAMA General Aviation Subset, 2 nd Edition. The output data includes navigation, flight plan and GPS vertical guidance information to the following systems: Bendix/King EFS 40/50 without SW15/01 update (GPS vertical guidance provided on EFIS)
GAMA 429 Graphics	ARINC 429 data as defined by the GAMA General Aviation Subset, 2 nd Edition including GAMA Graphics Protocol ‘A’. This format outputs intersection symbols as generic waypoint symbols. The output data includes navigation and flight plan information (including graphical representation of the flight plan procedures) to the following systems: Honeywell Primus 1000
GAMA 429 Graphics w/Int	ARINC 429 data as defined by the GAMA General Aviation Subset, 2 nd Edition including GAMA Graphics Protocol ‘A’. The output data includes navigation and flight plan information (including graphical representations of flight plan procedures) to the

Selection	Description
	following systems: Sandel SN3308 Sandel SN3500 Aspen EFD1000 (see note below) Avidyne EX500 Avidyne EX600 Avidyne EX5000 Note: When integrating an Aspen EFD1000 with a dual IFD installation, ensure the "CRS SDI" field in the Aspen setup pages (page 18) is set to Nav 1/2 and not Common.
GAMA 429 Pro Line 21	ARINC 429 data as defined by the GAMA General Aviation Subset, 2nd Edition.
GAMA 429 Sextant	ARINC 429 data as defined by the GAMA General Aviation Subset, 2nd Edition
GAMA 429 Non-standard	ARINC 429 data that is not necessarily conforming to the GAMA General Aviation Subset, 2 nd Edition.
GAMA 429 Thales	GAMA 429 Customized for Thales
ARINC 743A	ARINC 473A-5 Navigation Block Data
ARINC 743A+	ARINC 473A-5 Navigation Block + Measurement Block
Onboard Radar	Honeywell RDR2000
Becker BXT Ctl	Becker BXT 65XX Transponder Control This ARINC 429 speed should be set to the high speed.

Table 97 ARINC 429 Output Selection

SDI

Note: It is important in dual IFD installations that the corresponding SDI selection be made properly. That typically means selecting LNAV 1 or LNAV 2.

Selection	Description
Common	Rx: Accepts all 429 inputs Tx: Generates all 429 outputs with SDI = 0
LNAV 1	Number 1 (Pilot) long-range navigator RX: Accepts 429 inputs with SDI = 0 or 1. TX: Generates all 429 outputs with SDI = 1.
LNAV 2	Number 2 (Copilot) long-range navigator RX: Accepts 429 inputs with SDI = 0 or 2. TX: Generates all 429 outputs with SDI = 2.

Table 98 SDI Selection

VNAV

Selection	Description
Disable Labels	<p>ARINC 429 labels associated with GPS-based vertical guidance (labels 117G and 327G) are not transmitted in the output data stream.</p> <p>Note: If replacing an existing GNS-530 and the VNAV field was not present on the 530, then select "Disable" on the IFD.</p>
Enable Labels	<p>ARINC 429 labels associated with GPS-based vertical guidance (labels 117G and 327G) are transmitted in the output data stream.</p> <p>ARINC 429 vertical: Sandel SN3500 Aspen EFD1000 Other systems may also use these labels.</p>

Table 99 VNAV Selection

7.5.4 RS-232 Port Configuration 

The RS-232 Configuration Page allows the configuration Inputs and Outputs to match that of the equipment installed in the aircraft.



Figure 13 RS-232 IFD5XX Configuration Page

Note: Shown is an IFD5XX/Atlas Main RS232 Config Page. The IFD4XX only has 4 inputs and outputs

Note: For s/w 10.2.0 and earlier, if you configure Skytrax WX, Capstone Wx, MLB Wx, or WX500 on any input channel, the same numbered output channel cannot be configured with any of the following; ADS-B (Avi), ADSB, ADS-B+ (G), GDL 88, Aviation, Avtn no alt, HW EGWS, MapMX.

Note: RS232 Input 3 and Output 3 should only be used for CrossSync functionality. In single IFD installations configure RS232 Input 3 and Output 3 to Off.

The following selections can be made on the RS-232 Input.

Channel Inputs

Selection	Description
Off	No device(s) connected to input of this channel
Arnav/ei-fuel	Serial fuel flow information from the following units: ARNAV FC-10, FT-10 Electronics International FP-5L
AXP322	Select for Avidyne AXP322 Remote Transponder
CrossSync	Allows synchronization of flights plans, user waypoints, alerts and cross-side data (e.g. RS-232 Datalink, traffic, lightning, etc) between IFD units. Remote tuning of cross side radio is also (optionally) available. Transponder controls are not cross synced. Note: This is only an option for CHNL 3.
GDL 69 ¹	Serial data input for in-flight access to weather and messaging from the following units: Garmin GDL69/69A P/N 011-00986-00 or 011-00987-00 only (Garmin software version 4.01 or later) pre Avidyne software 10.2.3.1. With software 10.2.3.1 and later P/N 011- 03177-X0 will also work
XMD076 ¹	Serial weather data information from the Heads-up XMD-076
XMD076 AUX ¹	Read-only serial weather data information from the Heads-up XMD-076 to be used when a different device is controlling the Heads-up device.
Skytrax Wx ¹	Serial weather data only information from the Avidyne Skytrax100/SkyTrax200/MLB100 or Freeflight FDL-978-RX
SkyTrax Trfc ²	Serial traffic data only information from the Avidyne Skytrax100/MLB100 or Freeflight FDL-978-RX
SkyTrax Trfc+Wx ^{1,2}	Serial traffic and weather data information from the Avidyne Skytrax100/MLB100 or Freeflight FDL-978-RX
Capstone Wx ¹	Garmin GTX 345 and other 3 rd party compatible ADS-B weather devices transmitting at 38400 baud.
Capstone Trfc ²	Garmin GTX 335/345 and other 3 rd party compatible ADS-B traffic devices transmitting at 38400 baud.
Capstone Trfc+Wx ^{1,2}	Garmin GTX 345 and other 3 rd party compatible ADS-B traffic and weather devices transmitting at 38400 baud.
Capstone HS Wx ¹	Serial weather data information from any High Speed Capstone compliant ADS-B device transmitting at 115200 baud.
Capstone HS Trfc ²	Serial traffic data information from any High Speed Capstone compliant ADS-B traffic device at 115200 baud.
Capstone HS Trfc+Wx ^{1,2}	Serial traffic and weather data information from any High Speed Capstone compliant ADS-B traffic device at 115200 baud.
MLB100 Wx ¹	Serial weather data only for existing MLB100 installs.
Freeflight ^{1,2}	Serial Freeflight transponder control protocol along with High Speed Capstone ADS-B traffic and weather data information from a Freeflight Ranger device.

Selection	Description
NGT9000R	Serial transponder control protocol to control an L3 NGT9000R remote mount transponder.
Icarus-alt	Serial altitude data from the following units: Icarus Instruments 3000 Sandia SAE5-35 Garmin GTX 327 Transponder Trans-Cal Industries IA-RS-232-X, SSD120 ACK Technologies A-30 (Mod 8 and above)
Ryan TCAD ²	Traffic information from a Ryan 9900B, 9900BX, or TAS6XX Series System.
Shadin-adc	Serial airdata information from the following units: Shadin ADC 200, 200+, 2000
Shadin-alt	Serial altitude data from the following units: Shadin 8800T, 9000T, 9200T
Shadin-fadc	Shadin 9628XX-X Fuel/Air Data Computer Insight TAS 1000 Air Data Computer
Shadin-Fuel	Serial fuel flow information from the following units: Shadin 91053XP and 91053XT-D "Digiflo-L" Digital Fuel Management Systems Shadin 91204XX(38)D and 91204XT-D "Miniflo-L" Digital Fuel Management Systems JP Instrument EDM-700 or EDM-760 Engine Monitor Other JPI systems (e.g. JPI FS-450) can use this setting but see the specific format guidance from JPI for the Garmin GNS series.
WX-500	Serial lightning data information from the L3 Communications WX-500 Stormscope
TWX	Serial lightning data information from the Avidyne TWX670 in "Native" format
Vhf Ctrl	Reserved for future VHF remote control

Table 100 RS-232 Input Selection

¹ **These weather receiving devices are mutually exclusive. Only one source can be displayed at one time. The current display priority is:**

- GDL-69
- XMD076
- XMD076 Aux
- Capstone HS Wx
- Capstone HS Trfc+Wx
- MLB100 Wx
- Capstone Wx
- Capstone Trfc+Wx
- Freeflight

² **These Traffic receiving devices are mutually exclusive. Multiple devices should not be installed/configured on a single unit.**

Channel Outputs

Selection	Description
Off	No device(s) connected to output of this channel
ADS-B (Avi) ³	Serial position data to the following units: Trig TT31 (V 3.1 or later) Avidyne AXP340
ADS-B+ (G)	Garmin GTX 330 Low Speed 9,600 Baud
ADS-B+ (G2)	Garmin GTX 335/GTX345/GDL 88 High Speed 38,400 Baud
Aviation ³	Serial position, altitude, velocity, and navigation data to the following units: Argus 3000, 5000, or 7000 Moving Map Avidyne FSD Series Garmin MX20 (V5.6 or later), GMX200 Garmin GPSMAP 195, GPSMAP 295 or GPS III Pilot Garmin GPSMAP 196, GPSMAP 296, and GPSMAP 396 Garmin GPSMAP 496, and GPSMAP 696 Garmin Aera 796/795 Garmin GTX 327 Transponder JP Instruments EDM-700 or EDM-760 Engine Monitor Shadin 91204XM Digital Fuel Management System Shadin 91053XP Digital Fuel Management System Shadin 9628XX-X Fuel/Air Data Computer Stormscope Series II (with NAVAID) Moving Map
Aviation no Alt ³	Serial position, velocity, and navigation data to the following units: Garmin MX20 (V5.5 or earlier) Horizon DDMP Insight TAS 1000 Air Data Computer
AXP322	Select for Avidyne AXP322 Remote Transponder
CrossSync	Allows synchronization of flights plans, user waypoints, alerts and cross-side data (e.g. RS-232 Datalink, traffic, lightning, etc) between IFD units. Remote tuning of cross side radio is also (optionally) available. Transponder controls are not cross synced. Note: This is only an option for CHNL 3.
GDL 69 ¹	Serial data output to a Garmin GDL69/69A P/N 011-00986-00 or 011-00987-00 only (Garmin software version 4.01 or later)
XMD076 ¹	Serial weather control
SkyTrax Trfc ²	Serial traffic and weather control information to the Avidyne Skytrax100/MLB100 or Freeflight FDL-978-RX
SkyTrax Trfc+Wx ^{1,2}	Serial traffic and weather control information to the Avidyne Skytrax100/MLB100 or Freeflight FDL-978-RX
Capstone Trfc ²	Garmin GTX 335/345 and other 3 rd party compatible ADS-B traffic devices
Capstone Trfc+Wx ^{1,2}	Garmin GTX 345 and other 3 rd party compatible ADS-B traffic and

Selection	Description
	weather devices.
Capstone HS Trfc ²	Serial traffic control information y High Speed Capstone compliant ADS-B traffic device at 115200 baud.
Capstone HS Trfc+Wx ^{1,2}	Serial traffic and weather control information to High Speed Capstone compliant ADS-B traffic device at 115200 baud.
MLB100 Wx ¹	Serial weather data only for existing MLB100 installs.
HW EGPWS ³	Serial communication to a Bendix/King KGP 560 EGPWS
Freeflight ^{1,2}	Serial Freeflight transponder control protocol along with High Speed Capstone ADS-B traffic and weather data information from a Freeflight Ranger device.
NGT9000R	Serial transponder control protocol to control an L3 NGT9000R remote mount transponder.
MapMX ³	Serial position, altitude, velocity, and navigation data to the following units: Garmin MX20 (V5.7 or later), GMX 200
Ryan TCAD ²	Traffic information and control to a Ryan 9900B, 9900BX, or TAS6XXA Series System.
WX-500	Serial communication to L3 Communications WX500 Stormscope
TWX	Serial communication to the Avidyne TWX670
Vhf Ctrl	Reserved for future VHF remote control
Raw-GPS	Reserved

Table 101 RS-232 Output Selection

¹ These weather receiving devices are mutually exclusive. Only one source can be displayed at one time. The current display priority is:

- GDL-69
- XMD076
- XMD076 Aux
- Capstone HS Wx
- Capstone HS Trfc+Wx
- MLB100 Wx
- Capstone Wx
- Capstone Trfc+Wx
- Freeflight

² These traffic receiving devices are mutually exclusive. Multiple devices should not be installed/configured on a single unit.

³ The following RS232 Output protocols may be configured on two or more RS232 ports: Aviation, Aviation No Altitude, ADS-B (avi), HW EGPWS, and MapMx.

7.5.5 Main System Configuration 

This is a general page for miscellaneous configurations.

Main System Config			
Fuel Type	AV Gas	Joystick Input	Disabled
GPS Select	Auto	Appr Roll Steer	Enabled
Airframe	Helicopter	Nav Radio Active	Enabled
Multi-Engine	Enabled	Charts	Enabled
Tail Number	N51166	BEW	15000 lb.
External TAWS	No	MTOW	25000 lb.
WOW Input (Helo)	No	MLW	20000 lb.
Checklists	Enabled	RF Legs	Enabled
TIS-B Annunciation	Enabled	Enroute VNAV	Enabled

Figure 14 Main System Configuration Page

The Main System Configuration Page (Page 3 of 15) allows the configuration of the following Airframe Options and GPS Parameters on the IFD.

Fuel Type Selections:

Selection	Description
Avgas	The aircraft is using Aviation gas (5.967 lbs/gal)
Jet A	The aircraft is using Jet A or Jet A-1 fuel (6.843 lbs/gal)
Jet B	The aircraft is using Jet B (JP-4) fuel (6.467 lbs/gal)

Table 102 Aircraft Fuel Type

GPS Select Selections:

Selection	Description
Auto	In GPS mode on the IFD, the GPS Select discrete will not be active (open) in a GPS approach, and no messages will annunciate on the IFD and no pilot action is required. This setting allows the pilot to use the GPS → VLOC Capture option on the User Options part of the Setup tab on the AUX page.
Prompt	In dual IFD installations, only the IFD connected to a KFC225 autopilot should be setup for prompt. In GPS mode, the user will be prompted to enable the approach in KFC225 equipped aircraft When Prompt is selected, and a GPS approach mode is active, a CAS message will prompt the pilot to “Enable A/P Approach” on the FPL tab. At that point, the pilot may then enter APR mode on the autopilot. This setting will also ignore the GPS → VLOC Capture option on the User Options part of the Setup tab on the AUX page.

Table 103 GPS Sequencing

Airframe Selections:²

Selection	Description
Fixed Wing	For Fixed Wing installations
Helicopter	For Helicopter installations
High Speed	For Jet installations
Canard	For Fixed Wing installations (ownship symbol has a canard)

Table 104 Airframe Selection

Multi-Engine Selections:

Selection	Description
Disabled	For non-twin engine installations. Fuel pages show single value for total fuel quantity and fuel flow
Enabled	For twin engine installations. Fuel pages show separate values for fuel quantity and fuel flow, one per engine

Table 105 Multi-Engine Selection

Tail Number:

Tail number is a text field and is used for various purposes (i.e. Jeppesen data subscription, transponder function and optional IFD feature validation such as TAWS, 16 Watt VHF, GLAS, SAR, Radar etc.). Note if the tail number is not entered to match the paid option features installed at the factory or through the use of coupons or if the tail number should change for any reason doing subsequent software upgrades in the field will result in turning off those options. If the tail number of the aircraft is changed please contact Avidyne Technical Support at techsupport@avidyne.com and a file to restore the options can be emailed to you.

External TAWS Selections:

Selection	Description
Yes	Select if an external EGPWS or TAWS device (e.g. KGP 560) is connected to the IFD or if you want to turn off the FLTA. It will disable FLTA and TA functionality as well as aural alerts in the IFD
No	Select when no external EGPWS or TAWS device is connected to the IFD, thereby enabling all enabled IFD terrain alerting functions.

Table 106 External TAWS Selection

Remote data collection units can be configured to collect system information over the Wi

WOW Input (Helo)

Selection	Description
Yes	When set to "Yes" and the Airframe Selection is set to "Helicopter" Pin 70 on P1001 is used as a discrete input to control the in-air or on-ground state of the IFD. Logic state required is "low when on ground"
No	Select "No" when WOW discrete input is unavailable.

Table 107 Weight on Wheels

Checklist

Selection	Description
Enabled	Select Enabled to allow the user editable checklists to be displayed/accessible.
Disabled	Default setting

Table 108 Checklist Setting

TIS-B Annunciation

Selection	Description
Enabled	Select Enabled for installations in U.S.
Disabled	Outside US airspace

Table 109 TIS-B Annunciations

Joystick Input

Selection	Description
Enabled	Enables joystick input commands. Controls the automatic creation of user waypoints using external EFIS input. This setting shall be disabled when interfacing to the Proline 21 installations.
Disabled	Default setting

Table 110 Joystick Input

Appr Roll Steer

Selection	Description
Enabled	Default setting
Disabled	Invalidates GPSS Roll Steering output during FMS approaches. Should be disabled for autopilots that fly GPSS during approach mode to force the autopilots to switch to Left/Right deviation data.

Table 111 Roll Steering Setting

Nav Radio Active

Selection	Description
Enabled	Default setting
Disabled	When there is no nav antenna connected to the IFD

Table 112 Nav Radio Active Setting

Charts

Selection	Description
Enabled	Default setting
Disabled	Electronic charts capability is inhibited. The Map subsystem will not show a Charts tab, the Map tab will not show chart extent boxes, the FMS will not show chart icons. This setting is useful if the charts subscription has expired and there is no intent to update it. If enabled in that situation, the IFD will display a cautionary message at power up saying that the charts have expired.

Table 113 Charts Setting

BEW, MTOW, MLW

Aircraft Basic Empty Weight, Maximum Takeoff Weight, Maximum Landing Weight. All of these settings are numeric fields and are used to drive the Weight Calculator in the IFD. Rotating the inner knob changes the value by 10 pounds for each click. Values can range from 0 to 50000 pounds.

RF Legs

Selection	Description
Enabled	Enables the FMS to allow the selection of instrument procedures containing Radius-To-Fix (RF) legs, display those legs on the map, and provide guidance for active RF legs. This option should only be enabled if the aircraft is properly equipped (see AFMS).
Disabled	Default setting

Table 114 RF Legs Setting

Enroute VNAV

Selection	Description
Enabled	Default setting. Enables the "VNAV" function in the FMS to provide linear vertical deviations in descent during enroute and terminal navigation modes. Requires a baro-corrected altitude input. This option should only be enabled if the aircraft is properly equipped (see AFMS). Msg 126 Vertical Deviation and Msg 322 Flight Path Angle are

Selection	Description
	transmitted on GPS ARINC Output see Table 65 NOTE: VNAV integration to primary instruments or flight control systems requires separate approval if not specifically identified in this document
Disabled	Prevents the "VNAV" function in the FMS from providing vertical deviations during enroute and terminal navigation modes.

Table 115 Enroute VNAV Setting

Note: It is imperative that only one source of terrain cautions and warnings be enabled on the airplane so as to avoid the potential for conflicting information to be presented to the pilot. If a TAWS system is installed but the IFD's internal Fixed Wing TAWS (paid option), or TA and FLTA functions are to be used for terrain avoidance, the TAWS system *must* be fully disabled. If a separate TAWS system is to be used the caution and warning indications generated by the TAWS system can be displayed on a remote third party annunciator and the IFD's TA and FLTA displays and audio must be inhibited.

Note: The IFD system supports Honeywell EGPWS systems with a remote third party annunciator only. All other external TAWS/EGPWS systems must be disabled if the internal Fixed Wing TAWS (paid option) or TA and FLTA are to be operational

7.5.6 Main Input Configuration 

The Main Input Page displays information received from ARINC 429, RS-232, and other electrical inputs. This page is helpful during troubleshooting of the IFD system. This is used for verifying electrical interfaces during installation and troubleshooting.

Field	Description
OAT	Outside Air Temperature
SAT	Static Air Temperature
TAT	Total Air Temperature
IAS	Indicated Airspeed
W SPD	Wind Speed
HDG	True Heading
W DIR	Wind Direction
GPS SC	GPS Selected Course
VLC SC	VOR/LOC Selected Course (Not on IFD510/545/410)
CDI	Status of the CDI Key (Not on IFD510/545/410)
B ALT	Baro Corrected Altitude
D ALT	Density Altitude
P ALT	Pressure Altitude
JOYSTICK WPT	Latitude and longitude of a joystick waypoint sent by an EFIS or Radar indicator

Table 116 "Main Inputs" Page Fields

7.5.7 Main Lighting Configuration

The source of the lighting for the IFD can be the bezel photocell sensor or the dimming bus. 28VDC, 14VDC, 5VDC and 5VAC dimming buses are all supported and are automatically detected by the IFD.

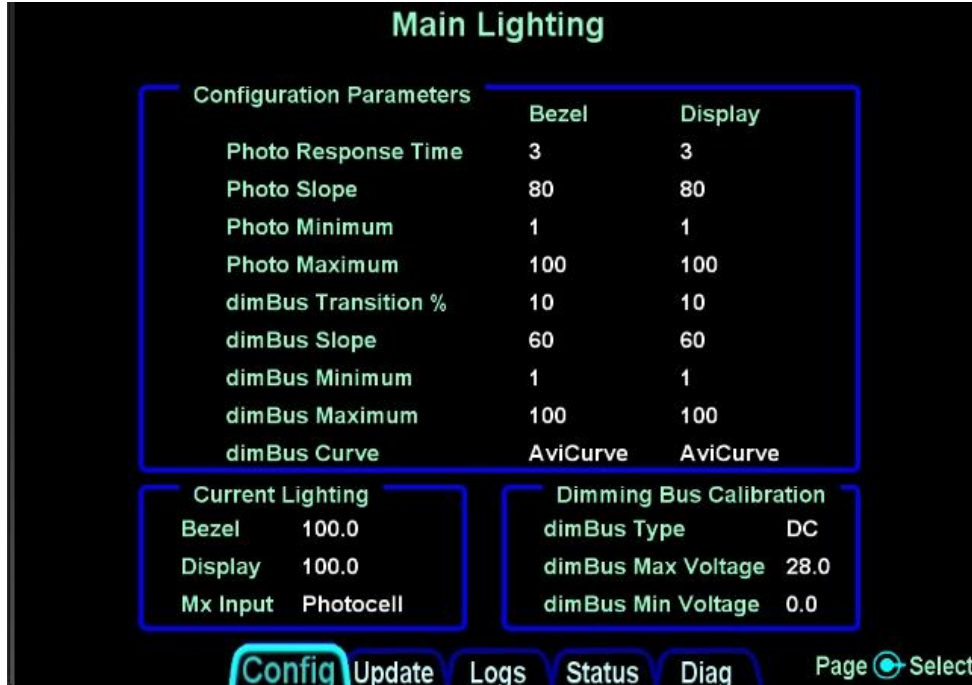

Figure 15 Main Lighting Configuration Page

Photo Response Time

Sets the speed at which the brightness changes when photocell is selected as the lighting source. Both the Bezel and Display fields have a range of 1 to 5, and the factory default is 3.

Photo Slope

The Photo Slope sets the sensitivity of the display/bezel to changes in the input when the dimming source is the IFD photocell. This field has a range of 15 to 100, and the factory default is 80.

Photo Minimum

The Photo Minimum sets the minimum brightness when the dimming source is the photocell. Both the Bezel and Display fields have a range of 1 to 50, and the factory default is 1.

Photo Maximum

The Photo Maximum sets the maximum brightness when the dimming source is the photocell. Both the Bezel and Display fields have a range of 50 to 100, and the factory default is 100.

dimBus Transition %

The dimBus Transition % sets the threshold where the aircraft dimming bus takes over from the photocell. Below this threshold, the aircraft dimmer controls the IFD lighting. Both the Bezel and Display fields have a range of 0 to 100, and the factory default is 10.

Note: If it is not desired to hand brightness control over to the dimming bus from the photocell at any point, set dimBus Transition % to 0 (zero). Doing so will prevent the scenario where, in increasingly darker environments (e.g. flying past sunset into dark night), the display automatically dims and dims and dims and then suddenly jumps to bright.

dimBus Slope

The dimBus Slope sets the sensitivity of the display/bezel to the aircraft dimmer. Both the Bezel and Display fields have a range of 15 to 100, and the factory default is 60.

Note: Previous to Release 10.1.1.0, a dimBus slope value of 100 on the AviCurve resulted in a maximum brightness value of 21%. In Release 10.1.1.0 and later, a slope value of 100 will result in 100% maximum brightness.

dimBus Minimum

The dimBus Minimum sets the minimum brightness when the aircraft dimmer is the dimming source. Both the Bezel and Display fields have a range of 1 to 50, and the factory default is 1.

dimBus Maximum

The dimBus Maximum sets the maximum brightness when the aircraft dimmer is the dimming source. Both the Bezel and Display fields have a range of 50 to 100, and the factory default is 100.

dimBus Curve

The dimBus Curve sets the aircraft dimming bus to either a Proportional Curve or AviCurve on the IFD.

The Proportional Curve tracks the aircraft lighting bus as follows: Maximum night lighting at maximum aircraft lighting bus voltage, Minimum night lighting at minimum aircraft lighting bus voltage (linear in-between).

The AviCurve tracks the aircraft dimming bus as follows:

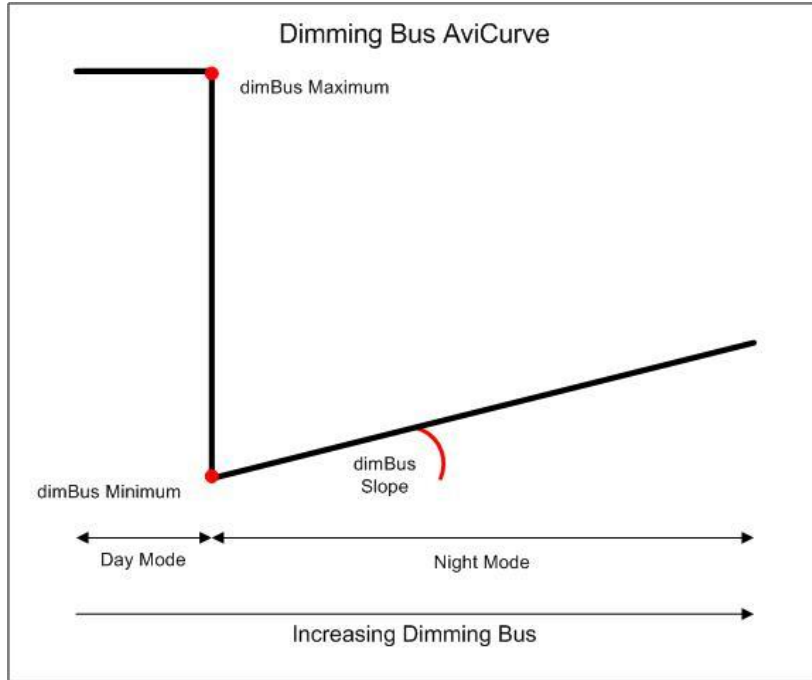

Figure 16 Lighting Curve – AviCurve

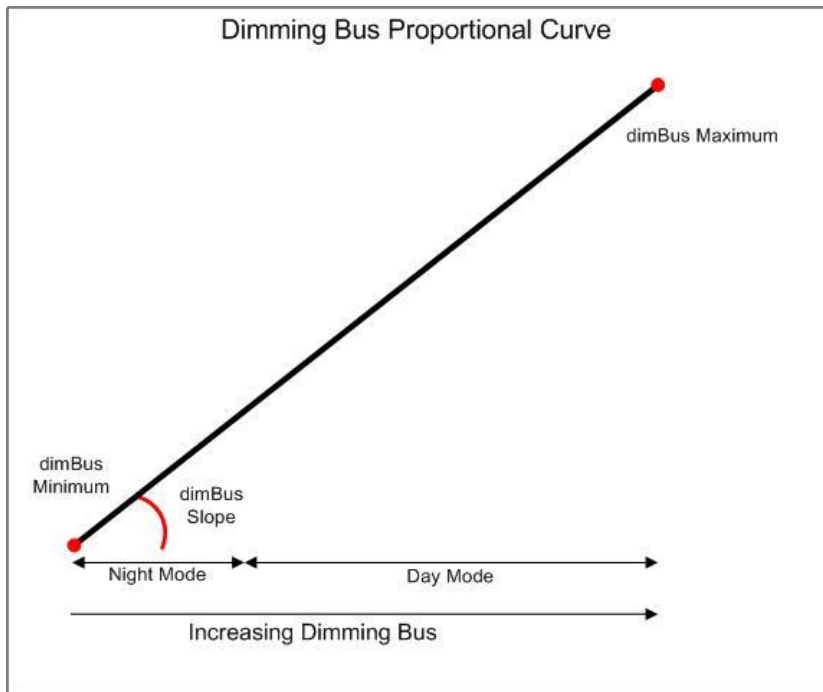

Figure 17 Lighting Curve - Proportional Curve

Field	Selection
Bezel	Value displayed represents the current % brightness of the bezel backlighting
Display	Value displayed represents the current % brightness of the display backlighting
Mx Input	<p>Photocell - Maintenance Mode will use this method if selected. This is the default setting. This setting uses the Photocell on the IFD bezel or display.</p> <p>dimBus - Maintenance Mode will use this method if selected. This setting uses the aircraft lighting bus to control the lighting of the bezel or display.</p>

Table 117 Lighting Bus Configuration

Dimming Bus Calibration

The section will calibrate the IFD to the aircraft avionics lighting bus.

Selection	Description
dimBus Type	<p>DC - select this option if the dimming bus is a DC bus.</p> <p>AC - select this option if the dimming bus is an AC bus.</p> <p>The IFD needs to know the bus type in order to alter internal configuration as well as properly perform the calibration.</p>
dimBus Max Voltage	Sets the maximum aircraft dimming bus voltage. Range is 0 - 28V.
dimBus Min Voltage	Sets the minimum aircraft dimming bus voltage. Range is 0 - 28V.

Table 118 Dimming Bus Calibration

To calibrate the dimming bus:

1. Select desired dimBus Type;
2. Select the dimBus Max Voltage field;
3. Push the right bezel knob;
4. Set the dimming bus to the maximum value (e.g. full clockwise position on dimming rheostat);
5. Push the right bezel knob to store;

Repeat the process for the minimum value (use full counter-clockwise position of rheostat)

7.5.8 Main Discrete I/O 

This page will test the Main Discrete outputs on the IFD.

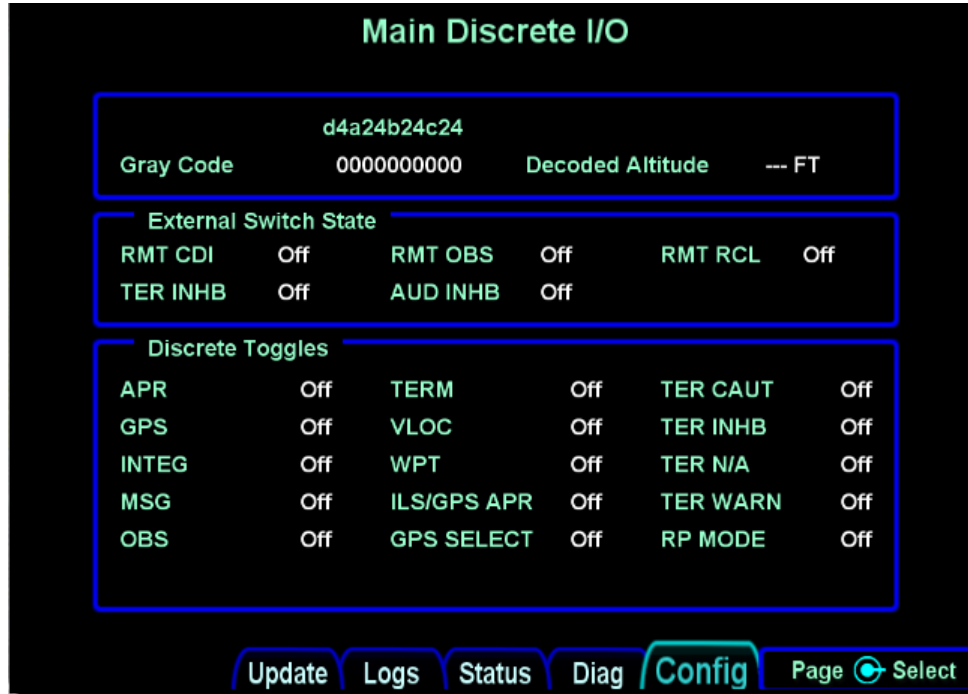

Figure 18 Main Discrete I/O Configuration Page

Selection	Verify That
RMT CDI	On is displayed when a remote CDI source select switch is pressed.
RMT OBS	On is displayed when a remote OBS switch is pressed.
TER INHB	On is displayed when a remote TERRAIN INHIBIT switch is pressed.
RMT RCL	On is displayed when the COM REMOTE RECALL switch is pressed.
AUD INHB	On is displayed when the audio inhibit discrete input is asserted.

Table 119 External Switch State

Selection	Verify That
APR	The APR annunciator is on or off as selected on this page.
GPS	The GPS source select annunciator is on or off as selected on this page.
INTEG	The INTEG annunciator is on or off as selected on this page.
MSG	The MSG annunciator is on or off as selected on this page.
OBS	The OBS annunciator is on or off as selected on this page.
TERM	The TERM annunciator is on or off as selected on this page.

Selection	Verify That
VLOC	The VLOC source select annunciator is on or off as selected on this page.
WPT	The WPT annunciator is on or off as selected on this page.
ILS/GPS APR	The ILS/GPS APR output is on or off as selected on this page (NOTE: This output is connected to the autopilot ILS ENGAGE input, not to an annunciation, and therefore this is for bench testing purposes only).
GPS SELECT	The GPS SELECT output is on or off as selected on this page (NOTE: This output is connected to the autopilot GPS SELECT input, not to an annunciation, and therefore this is for bench testing purposes only).
TER CAUT	The TER CAUT annunciator is on or off as selected on this page.
TER INHB	The TER INHB annunciator is on or off as selected on this page.
TER N/A	The TER N/A annunciator is on or off as selected on this page.
TER WARN	The TER WARN annunciator is on or off as selected on this page.
RP MODE	The Reduced Protection annunciator is on or off as selected on this page. Applicable only when HTAWS is enabled (TAWS and HELO options both enabled).

Table 120 Discrete Toggles

7.5.9 Main CDI/OBS Config Page

This page will test the Main CDI/OBS output on the IFD.

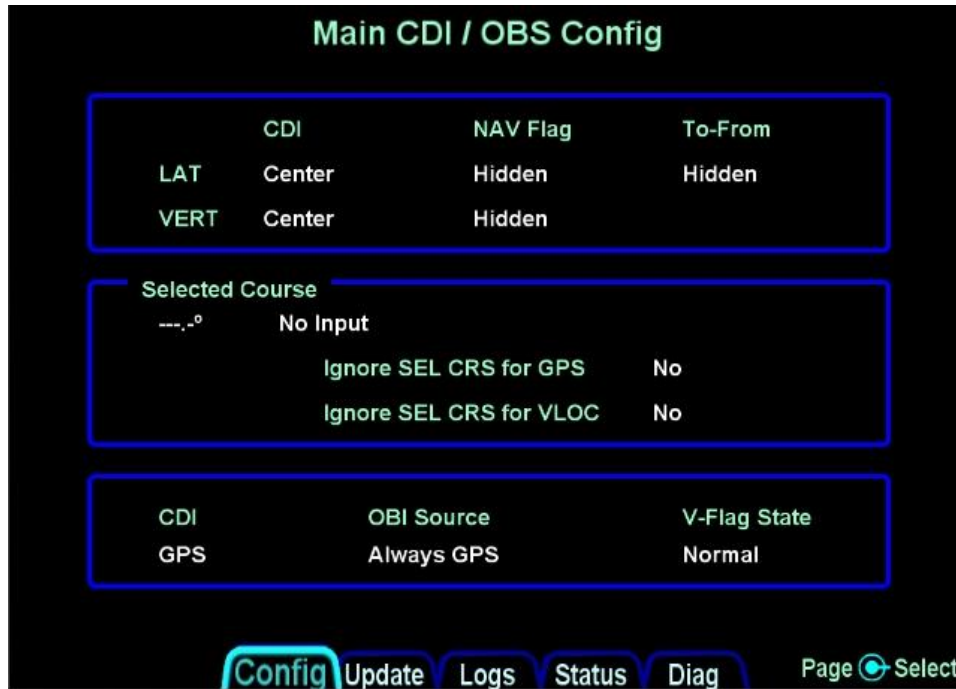

Figure 19 Main CDI/OBS Configuration Page

The following parameters can be tested:

CDI (LAT/VERT)

Selection	Description
Max Left	The remote CDI will be off-scale full deflection to the left/up
Full Left	The remote CDI will be deflected to the left/up
Center	The remote CDI will be centered
Full Right	The remote CDI will be deflected to the right/ down
Max Right	The remote CDI will be off-scale full deflection to the right/ down

Table 121 Main CDI Test Page

NAV Flag (LAT/VERT)*

Selection	Description
Hidden	The lateral and vertical flag on the external indicator is hidden
In view	The lateral and vertical flag on the external indicator is in view

**This function will only test the low level flags, and does not support the testing of Super Flags*

Table 122 Main CDI Flag Test Page

TO-FROM

Selection	Description
FROM	The FROM flag on the external indicator is in view
Hidden	The TO/FROM flag on the external indicator is hidden
TO	The TO flag on the external indicator is in view

Table 123 Main CDI Flag Test Page

Selected Course

This section will calibrate the external CDI/HSI to the IFD.

1. Select 150° on the CDI/HSI;*
2. Verify the Selected Course is displayed on the IFD and press the ENTR button on the IFD.
3. After calibrating, verify 30° increments on the CDI/HSI are properly displayed on the IFD $\pm 2^\circ$.

* In order to do the OBS calibration on a KI208A or KI209A, you have to toggle to the "Main Discrete I/O" page, and turn "ON" the GPS discrete toggle. Then turn to the Main CDI/OBS config page (without toggling back to the Discrete I/O page) and calibrate the OBS by dialing 150 degrees on the indicator.

Ignore Options

Selection	Description
Ignore SEL CRS for GPS	Yes/No - Nav Source knob used in OBS. Yes = ignore analog or 429 selected course. OBS mode then uses the Nav Source knob to dial the course.
Ignore SEL CRS for VLOC (N/A for IFD510/545/410)	Yes/No - Yes = Lateral navigation flag displays VOR validity, deviation data for VOR is always centered. No = deviation and flag data is based on OBS selection.

Table 124 Ignore Options Selection

CDI Selection

Selection	Description
GPS	The GPS is the navigation source. The GPS annunciator will also be active. This is the setting for IFD510/545/410
VLOC (N/A for IFD510/545/410)	The VLOC is the navigation source. The VLOC annunciator will also be active.
GPS Only (N/A for IFD510/545/410)	The VLOC selection on the IFD Nav Source knob has been disabled. Therefore, GPS and OBS are the only two available choices via the IFD Nav Source knob

Table 125 CDI Source Selection

OBI Source

Selection	Description
Always GPS	The MAIN Serial OBI output will always be selected to GPS.
Track CDI	The MAIN Serial OBI will track the Nav Source knob selection.

Table 126 OBI Source Selection

V-Flag State

Selection	Description
Declutter	The vertical deviation bar will be in parked in the maximum UP position when the vertical flag is removed, except in the following cases: <ul style="list-style-type: none"> VLOC is selected on the Nav Source knob and an ILS frequency is tuned (N/A for IFD510/545/410) GPS is selected on the Nav Source knob and valid GPS approach is active (precision GPS with vertical guidance)
Normal	The vertical deviation bar will be in the center position when vertical navigation is invalid and the vertical flag will be present.

Table 127 V-Flag State

7.5.10 VOR/LOC/GS CDI

Note: This page is not applicable for the IFD510/545/410 or Atlas FMS Only units.

This will test the operation of the VOR/LOC/GS output from the IFD on the P1006 connector to an external CDI/HSI display.



Figure 20 CDI Test Page

Note: This page currently will only test low level flags and does not support the testing of super flags

CDI (LAT/VERT)

Selection	Description
Max Left	The external CDI will be off-scale full deflection to the left/up
Full Left	The external CDI will be deflected to the left/up
Center	The external CDI will be centered
Full Right	The external CDI will be deflected to the right/down
Max Right	The external CDI will be off-scale full deflection to the right/down

Table 128 Navigation CDI Test Page

NAV Flag (LAT/VERT)

Selection	Description
Hidden	The lateral and vertical flag on the external indicator is hidden
In view	The lateral and vertical flag on the external indicator is in view

Table 129 Navigation Flag Test Page

SPR Flag (LAT/VRT Super Flag)

Selection	Description
Hidden	The lateral and vertical flag on the external indicator is hidden
In view	The lateral and vertical flag on the external indicator is in view

Table 130 NAV Superflag Test Page

TO-FROM

Selection	Description
FROM	The FROM flag on the external indicator is in view
Hidden	The TO/FROM flag on the external indicator is hidden
TO	The TO flag on the external indicator is in view

Table 131 Navigation TO/FROM Page

Selected Course

This section will calibrate the external CDI/HSI to the IFD.

1. Select 150° on the CDI/HSI;*
2. Verify the Selected Course is displayed on the IFD and press the ENTR button on the IFD;
3. After calibrating, verify 30° increments on the CDI/HSI are properly displayed on the IFD $\pm 2^\circ$.

* In order to do the OBS calibration on a KI208A or KI209A, you have to toggle to the "Main Discrete I/O" page and turn on the GPS discrete toggle. Then turn to the Main CDI/OBS config page (without toggling back to the Discrete I/O page) and calibrate the OBS by dialing 150 degrees on the indicator

DME Channel Mode

This configuration allows you to set the format for the DME tuning data output.

Selection	Description
UNINSTALLED	No DME installed/configured
King Serial	King Serial DME tuning
Parallel 2x5	2 of 5 parallel DME tuning
Parallel BCD	Shifted BCD (Binary Coded Decimal) parallel DME tuning
Parallel Slip	Slip-code parallel DME tuning
Narco 890/891	2 of 5 parallel DME tuning, compatible with the following DME units: Narco DME 890 Narco DME 891 ARC (Cessna) RTA-476A

Table 132 DME Channel Mode

7.5.11 VOR/LOC/GS ARINC 429 Configuration 

Note: This page is not applicable for the IFD510/545/410 or Atlas FMS Only units.

This page will configure the ARINC 429 for the VOR/LOC/GS output.



Figure 21 VOR/LOC ARINC 429 Configuration Page

The following parameters can be configured.

Speed:

Selection	Description
Low	Standard Low-speed ARINC 429
High	High-speed ARINC 429

Table 133 VOR/LOC/GS ARINC 429 Speed Configuration

Format:

Selection	RX/TX	Description
OFF	RX	No data will be processed from an external device
Proline VHF	RX	Processes VOR, LOC, G/S, and frequency information from a remote Pro Line 21 radio. Required to be paired with the Proline VHF/GPS TX option
VHF 429	TX	Standard VOR, Localizer, Glideslope, and Frequency information
VHF/GPS 429	TX	Standard VOR, Localizer, Glideslope, Frequency information as well as Pseudo Localizer and Pseudo Glideslope during GPS approach with CDI set to GPS.
Proline VHF/GPS	TX	Pass-through of Pro Line 21 radio data as well as pseudo LOC and G/S during GPS approach with CDI set to GPS.
VHF Thales	TX	Standard VOR, Localizer, Glideslope, Frequency information as well as Transponder and Diagnostic data

Table 134 VOR/LOC/GS ARINC429 Format Selection

SDI:

Selection	Description
Common	RX: Accepts all 429 inputs TX: Generates all 429 outputs with SDI =0
VOR/ILS 1	Number 1 (Pilot) VOR/ILS Receiver RX: Accepts 429 inputs with SDI = 0 or 1 TX: Generates all 429 outputs with SDI = 1
VOR/ILS 2	Number 2 (Copilot) VOR/ILS Receiver RX: Accepts 429 inputs with SDI = 0 or 2 TX: Generates all 429 outputs with SDI = 2

Table 135 VOR/LOC/GS SDI Selection

DME Mode:

Selection	Description
Directed Freq 1	If the IFD is connected to a single-channel or multi-channel ARINC429 DME, Direct Freq 1 will channel Receiver 1.
Directed Freq 2	If the IFD is connected to a multi-channel ARINC429 DME, Direct Freq 2 will channel Receiver 2

Table 136 DME Mode Selection

7.5.12 Com Setup

Note: This page is not applicable for the IFD510/545/410 or Atlas FMS Only units.



Enable Custom Squelch

Selection	Description
No	Default squelch values will be used
Yes	The custom squelch value entered will be used for COM squelch

Table 137 Enable Custom Squelch Setting

Custom Squelch Level

Custom squelch level is a numeric field ranging from 50% to 80%. Rotate the inner knob to adjust the numeric value by 1% with each click.

7.5.13 GPS Setup

This page will configure the GPS Receiver for the antenna offset on the aircraft and designate if the IFD will use the WAAS functionality of the system.

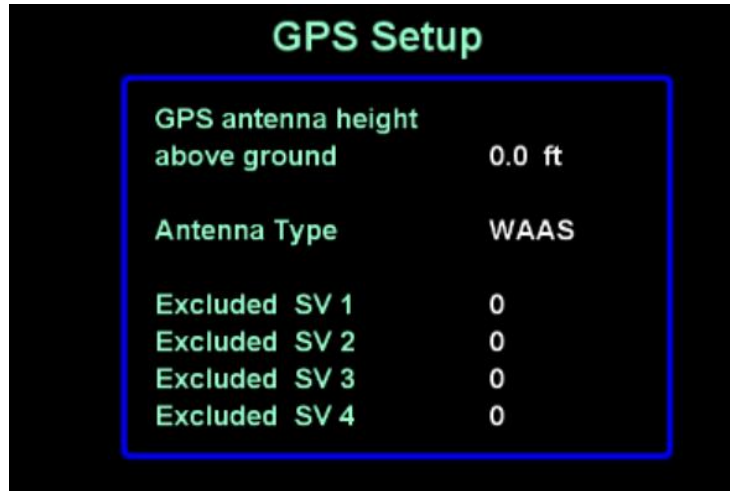

Figure 22 GPS Antenna Setup

Measure the distance from the ground to the top of the GPS antenna to nearest tenth of a foot, as shown in the image below, and enter the value into the IFD (to the nearest 1/10th foot).

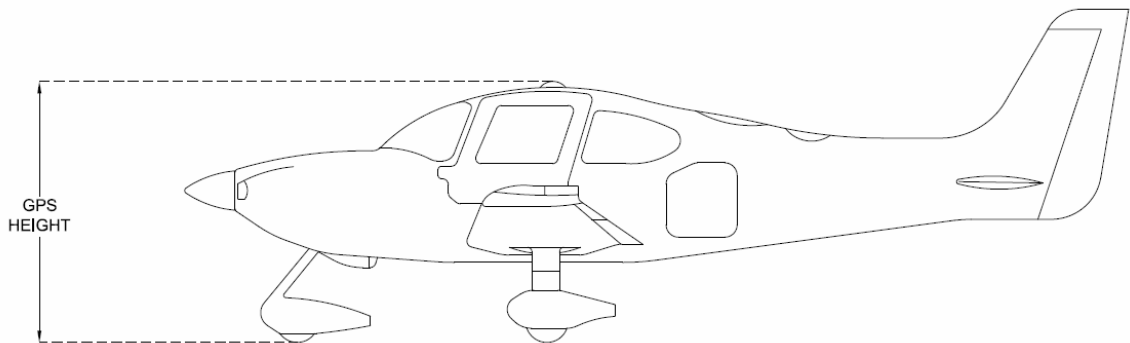

Figure 23 GPS Height

Antenna Type

Selection	Description
WAAS	The GPS antenna connected to the IFD is approved for use in SBAS operations.
Non-WAAS	The GPS antenna connected to the IFD is <i>not</i> approved for use in SBAS operations

Table 138 Antenna Type Setting

Excluded SV 1, 2, 3, 4

These fields are used to prevent the GPS from using the specified satellites, by SV number. Rotate the inner knob to change the satellite number. Set all fields to zero to prevent the GPS from excluding any satellites.

7.5.14 Main ARINC 429 Port 3 Configuration

This page will configure a GLAS enabled IFD to transmit a pseudo VOR/ILS output to the flight displays and autopilot on ARINC 429 port 3. Only configure this setting if high speed VOR/ILS ARINC out is specified on the drawing.



Figure 24 ARINC 429 Port 3 Setup

Set the ARINC 429 speed to high and select Proline VHF/GPS in the Out 3 section.

7.5.15 GPS Legacy Avionics System (GLAS)

Description:

GLAS (GPS Legacy Avionics System) is a paid for software unlock that enables legacy avionics that are “pre-WAAS” to fly GPS approaches with vertical guidance via the existing EFIS A429 short range navigation (SRN)/VLOC input channel utilizing Avidyne proprietary software.

During GPS Approach operations, the IFD or Atlas communicates the selected GPS approach guidance on a dedicated ARINC 429 VLOC output channel. The result is displayed and coupled flight guidance information for GPS approaches utilizing the EFIS FGS SRN input channel(s).

With the GLAS option configured, the A429 VLOC TX/RX ports on P1006 are high speed / low speed configurable. The IFD P1050 connector also supports a dedicated GLAS A429 out channel where dual channeling is required.

The A429 GLAS settings in the IFD/Atlas will not work if GLAS enablement is not unlocked.

Approach Capabilities:

With the appropriately rated TSO-C190 GPS antenna installed and the IFD/Atlas configured correctly, GPS approach capabilities include the following:

LNAV: Lateral Guidance only. Standard GPS precision 0.3NM deflection

LNAV+V: Lateral Navigation w/ Advisory Vertical Guidance

LNAV/VNAV: Lateral and Vertical Navigation

LP: Localizer Performance (no vertical guidance)

LP+V: Localizer Performance w/ Advisory Vertical Guidance

LPV: Localizer Precision with Vertical Guidance.

Configuration:

There are two GLAS configuration options: Of these two, Proline VHF/GPS is only used when the IFD/Atlas on-board radio is not installed (IFD510/545).

VHF/GPS 429

When using the VHF/GPS 429 configuration, the IFD uses its internal VHF navigation sensor data up until a GPS approach is active. At this point "pseudo-ILS" data based on GPS deviations replaces the VLOC data.

Proline VHF/GPS

In situations where the IFD onboard VHF navigation is not installed (FMS+VCom or FMS only), or when the VHF navigation is not being utilized and turned off from the maintenance mode, the IFD can be inserted in the middle of the communication chain between the aircraft's existing VHF navigation sensor and the EFIS/FGS systems for the purpose of overriding the existing VHF nav data.

For this application the existing A429 VLOC data is interrupted. The information from the existing SRN sensor is then passed through the IFD for management.

7.5.16 GDL Configuration Pages

This page allows the configuration of the Garmin GDL 69/69A. This page is always displayed in Maintenance Mode. The GDL 69/69A must be activated prior to configuring the IFD, reference the GDL installation manual for setup and configuration information.

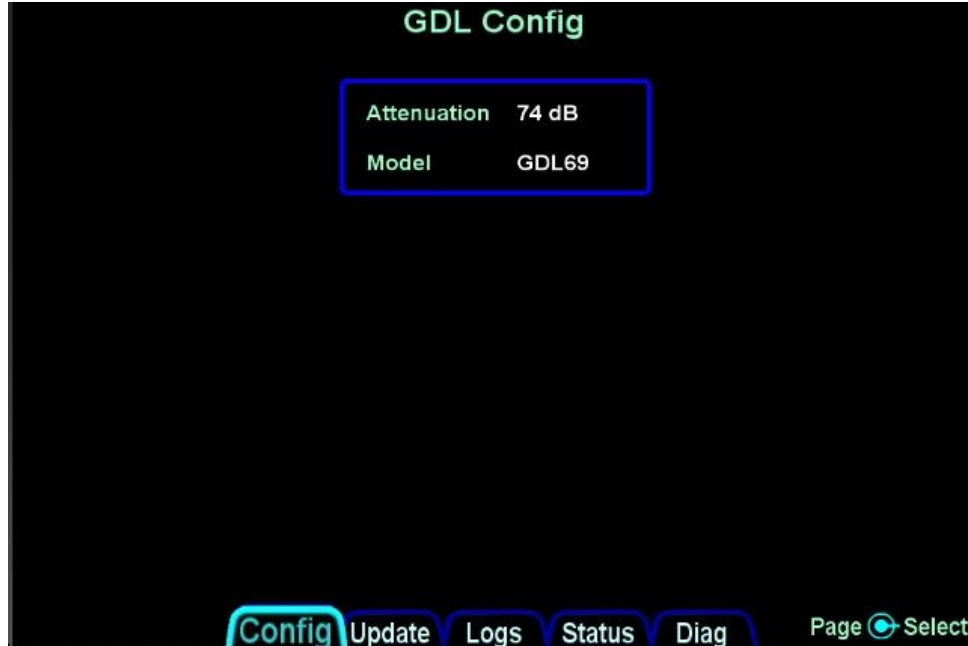

Figure 25 GDL Configuration Page

GDL Selection Page

This page selects the attenuation and the type of GDL receiver connected to the IFD.

Selection	Description
Attenuation	This parameter sets the attenuation GDL 69/69A. Reference the Garmin GDL69/69A installation manual for more information.
Model	This parameter sets the model to either GDL 69 (weather only) or GDL 69A (weather and audio) models.

Table 139 GDL Selection Page

Note Compatibility with P/N 011-00986-00 or 011-00987-00 only pre software 10.2.3.1. With software 10.2.3.1 or higher P/N 011-03177-X0 will also function

Note: If the GDL69/69A is connected to any other display in the aircraft, this attenuation setting must be set to match them.

7.5.17 Remote XPDR Configuration

This page will configure the Avidyne AXP322 Remote transponder. Reference the AXP322 installation manual as needed. The transponder must be configured to operate.

Please note; it may take up to 3 minutes to update the transponder configuration after changing a parameter below.

A dual AXP322 transponder installation will require that this function is performed on both transponders

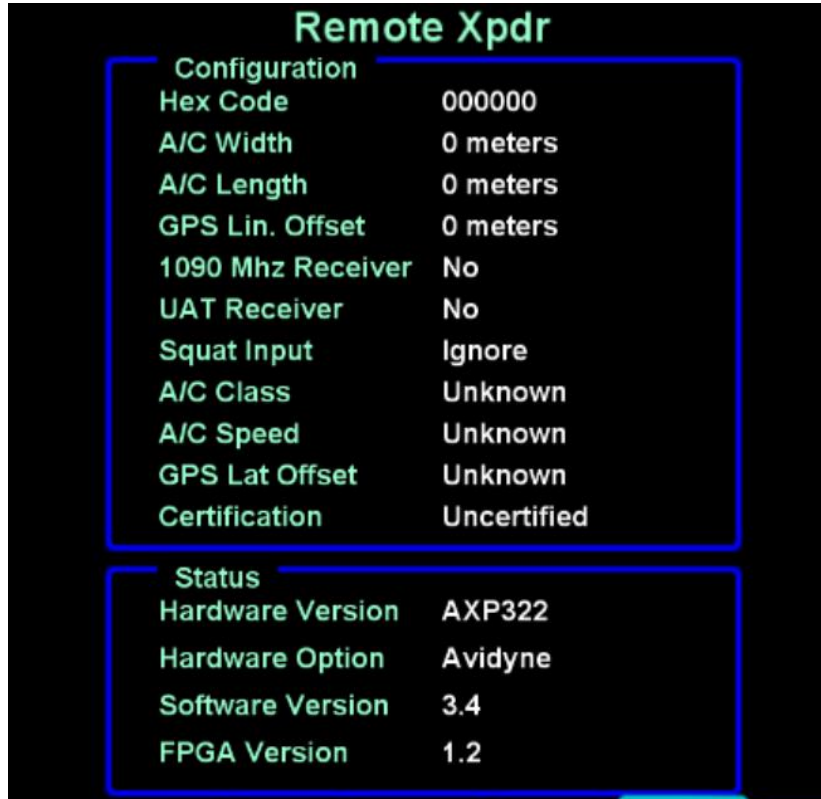

Selection	Description
Hex Code	Enter the aircraft's Mode S Address issued by the registration authority. This code must be entered as a hexadecimal value.
A/C Width	Enter the aircraft's width in meters
A/C Length	Enter the aircraft's length in meters
GPS Lin. Offset	Enter the distance from the front of the aircraft to the GPS antenna in meters
1090 MHz Receiver	Enter "Yes" if the aircraft is equipped with 1090 MHz ADS-B In receiver
UAT Receiver	Enter "Yes" if the aircraft is equipped with UAT ADS-B In receiver
Squat Input	For ADS-B out compliance, a squat switch is required for

Selection	Description
	<p>automatically transitioning the transponder to air/alt/ground modes of operation.</p> <p>For aircraft without a squat switch, connect the squat switch input of the transponder to P1001 pin 8 of one of the IFD5XX/IFD4XX and set the transponder to "Avidyne".</p> <p>If using an external squat switch, set this field to "Active Low+" or "Active High+" based on the polarity requirements of the external squat switch.</p>
A/C Class	Enter the aircraft category
A/C Speed	Enter the aircraft speed
GPS Lat. Offset	Enter the lateral distance in meters for the GPS antenna
Certification	<p>VFR installations, aircraft with a non-WAAS antenna (reference Section 7.5.12), or unapproved ADS-B out installations must set this field to "uncertified". All other installations reference the Avidyne AXP322 installation manual for certification level.</p>

Table 140 Remote XPDR Configuration Selections

7.5.18 Voice Call Outs Configuration

The IFD has the capability to generate an aural alert (a.k.a. “voice call out”) at certain AGL altitudes when approaching an airport. This page allows enabling or disabling of alerts at each of those altitudes. When the Fixed Wing TAWS option is enabled, the 500ft callout cannot be disabled. The IFD will only generate these aural alerts when either the F500 or TAWS option is enabled.

NOTE: If the IFD is configured for use with an external TAWS, this setting will not be shown and the altitude callouts will be inhibited as if the setting was “Off”.

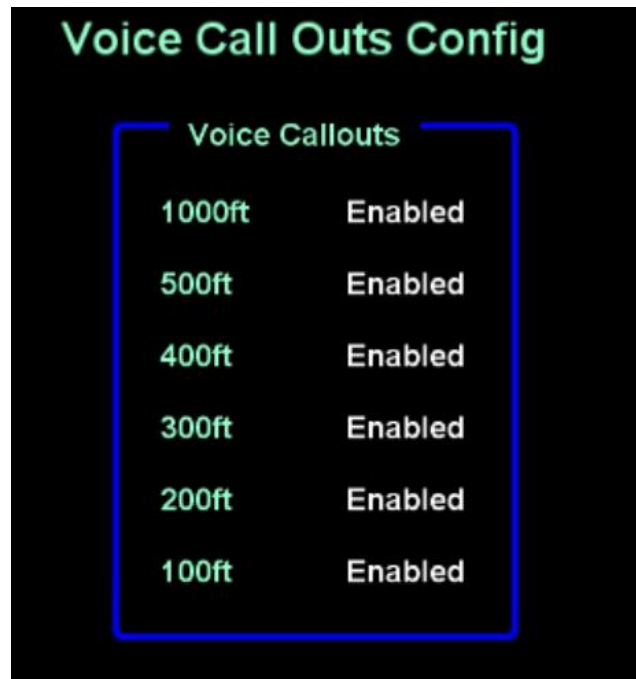

The image shows a screenshot of a configuration menu titled "Voice Call Outs Config". Inside the menu, there is a sub-section titled "Voice Callouts" which contains a list of altitudes and their corresponding status. All altitudes listed are set to "Enabled".

Voice Callouts	
1000ft	Enabled
500ft	Enabled
400ft	Enabled
300ft	Enabled
200ft	Enabled
100ft	Enabled

7.5.19 Wireless Portables

This page is used to configure the operation of the IFD with respect to wireless portable devices.



Capstone

Selection	Description
Enabled	<p>If the IFD has the PORTS option enabled and the IFD is not hardwired to an ADS-B In device*, and any CrossSync connected IFD is not hardwired to an ADS-B In device*, then the IFD can be configured to receive ADS-B data from a wireless portable device such as a Stratus 3.</p> <p>If all of the above conditions are true, then setting the Capstone configuration on this page to Enabled will enable the configuration to allow the IFD to receive ADS-B In data from the wireless device. Note that receipt of ADS-B data from the portable device must also be enabled via the flight mode setup pages. Finally, like all Wi-Fi connected devices, the Pilot will be required to “allow” the portable device to connect to the IFD. See Pilot Guide for details.</p> <p>* No RS-232 ports and no ARINC-429 ports are configured for an ADS-B In device</p>
Disabled	Default configuration

Table 141 Wireless Portables Selections

7.5.20 WiFi Setup

All WiFi setup is accomplished via the Flight Mode setup pages. See Pilot Guide for details.

7.5.21 Bluetooth Setup

The IFD has built-in Bluetooth capability that allows pairing with a remote keyboard. The keyboard can be used to easily enter waypoint identifiers, but it can also be used to change pages, move cursor, and tune radios.

As with all Bluetooth devices, a keyboard must be paired with the IFD before use. This pairing only needs to be done once and then that specific keyboard can be used every time the IFD is powered up. This page is used to establish the pairing.

After power up, the IFD goes through a process to initialize the Bluetooth interface. During that time, this page will show "Initializing..." and the aircraft will move across the screen from left to right, as illustrated below.

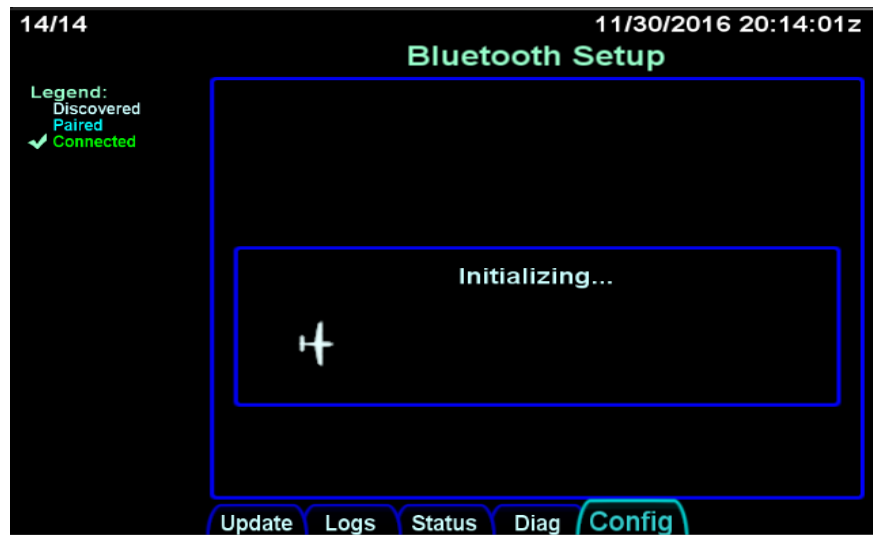

Figure 26 Bluetooth Setup Page – Initializing

Press the button on the back of the keyboard to make it discoverable. Then, press the "Start Scan" LSK on the IFD.

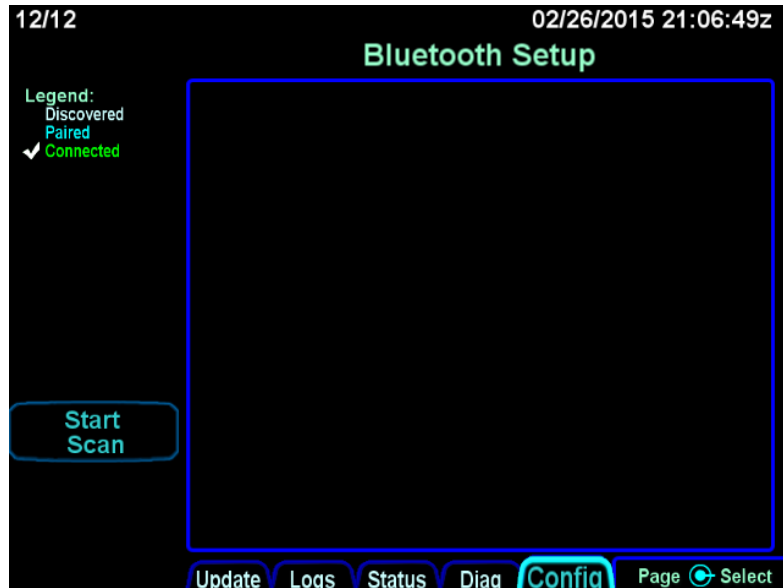

Figure 27 Bluetooth Setup Page – Start Scan LSK

After a while, the IFD will discover the keyboard and it will appear on the list of devices shown on the screen. At that point, press the "Stop Scan" LSK.

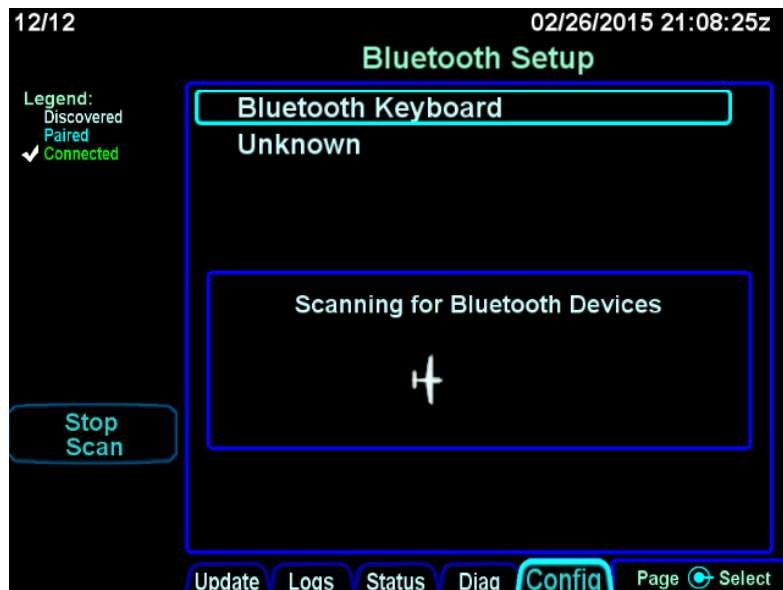

Figure 28 Bluetooth Setup Page – Keyboard discovered

After "Stop Scan" has been pressed, turn the right outer knob to move the cursor to the desired device. Press the "Pair Device" LSK and wait for a numeric pairing code to appear.

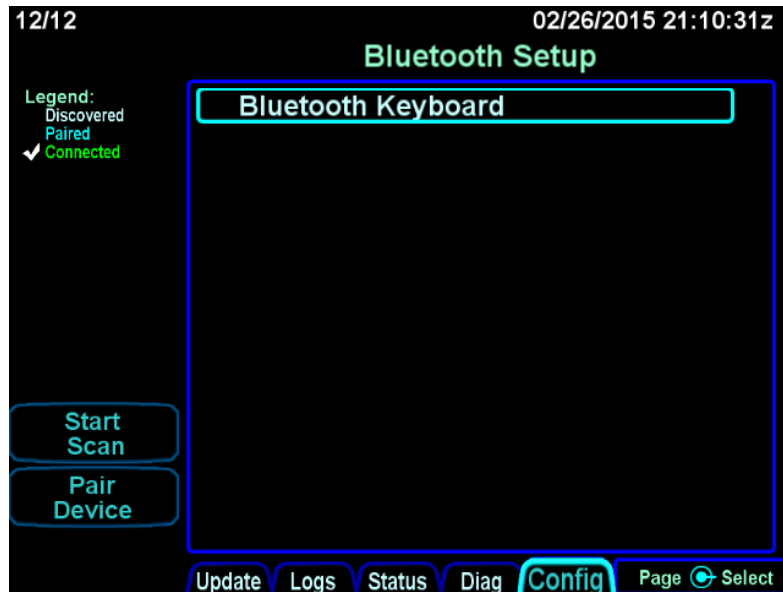

Figure 29 Bluetooth Setup Page – Pair Device LSK

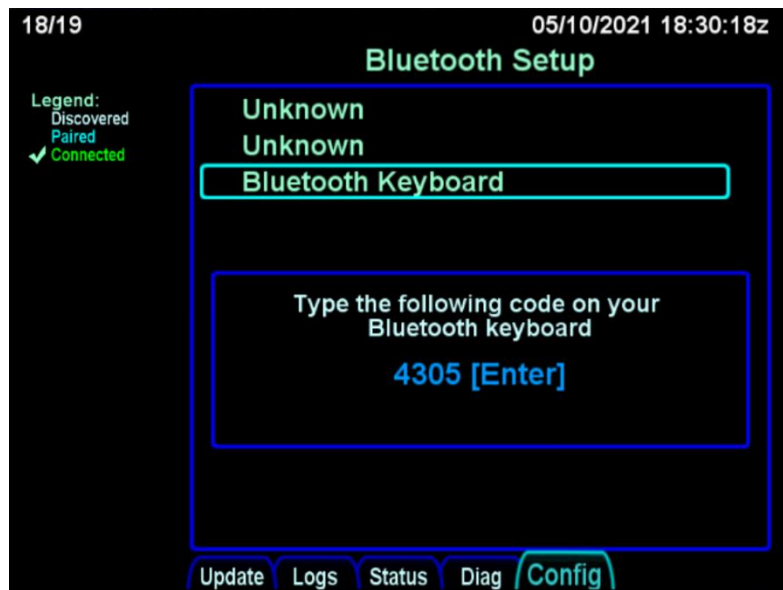

Figure 30 Bluetooth Setup Page – Pairing Code

On the keyboard, enter the numeric code followed by the keyboard’s ENTR key. If pairing was successful, the selected device in the list will be shown in green.

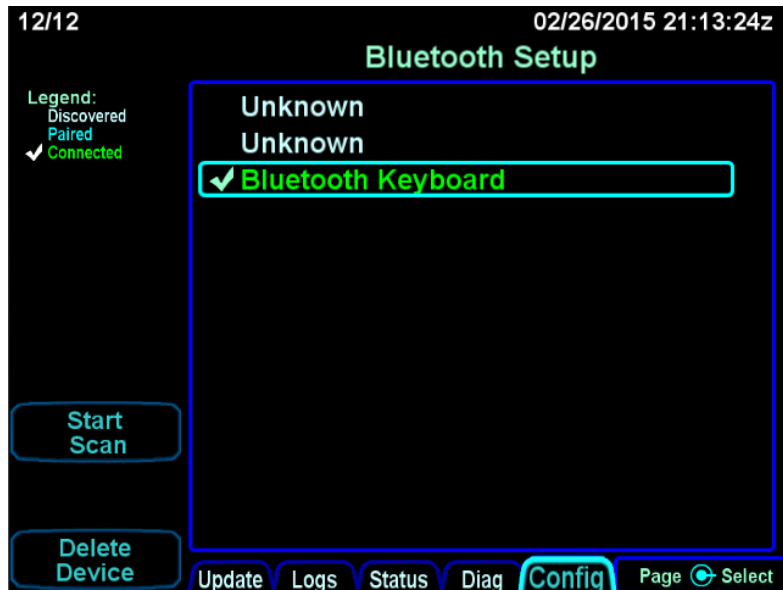

Figure 31 Bluetooth Setup Page – Pairing Successful

If the device is not shown in green or if the device name disappears from the display, restart the pairing process with pressing the button on the back of the keyboard. If repeated attempts to pair are unsuccessful, contact Avidyne Technical Support.

7.5.22 IRU Calibration, IFD545, IFD550, Atlas

In order to calibrate the IFD550, IFD545 or Atlas you must access the IRU Calibration page. This page can be found by:

1. Entering maintenance mode.
2. Accessing the Config tab by pressing the right side of the AUX key.
3. Turn the outer right knob until you see the IRU Calibration page (see picture below).

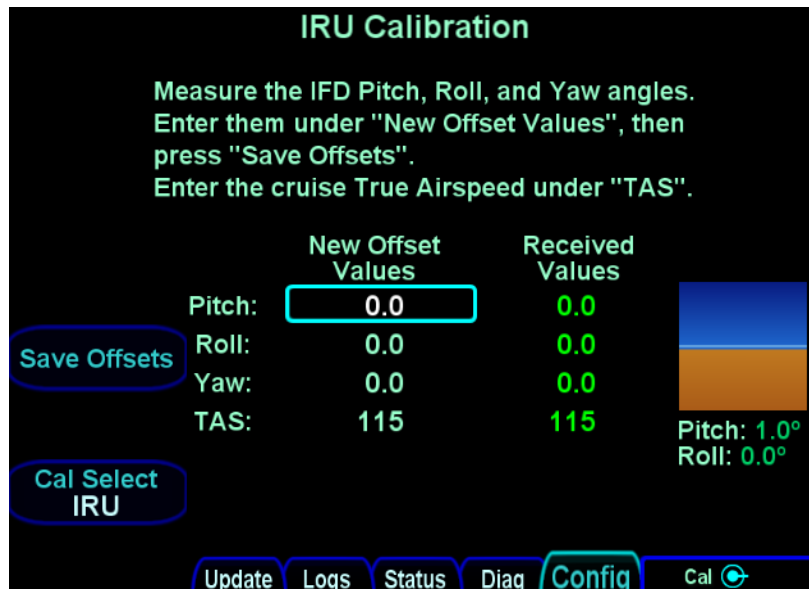

Figure 32 IRU Calibration Page

IFD550, IFD545, Atlas IRU require minimal calibration. The adjustment parameters available and their impact on the system behavior are discussed below.

Ensure that the calibration is performed with the aircraft on flat level surface and engines off. In order to adjust each of the parameters, you will press the right knob until the cursor advances to the value to be set. Use the inner knob to adjust the value. The small blue over brown window on the right side of the page will show suggested value changes to make when calibrating the IRU. For example in the picture above it is suggested to add +1.0° change to the Pitch: New Offset Value.

Once all settings have been adjusted as desired, press the "Save Offsets" LSK to save the values you have configured.

7.5.22.1 Setting TAS:

Press the right knob until the cursor advances and the TAS field is selected. Turn the right knob to change the value until it represents the cruise airspeed of the aircraft in knots. Look in the POH and set the TAS value to the 75% power at 6,000 ft. value.

NOTE: Setting of the TAS value is mandatory.

7.5.22.2 Adjusting Pitch Roll and Yaw

Your installation may not require the setting of pitch, roll, and yaw values. These values need only be set if the installation orientation of the IFD545/IFD550/ Atlas is not aligned with the lateral, vertical or longitudinal lines of the aircraft (see diagram below).

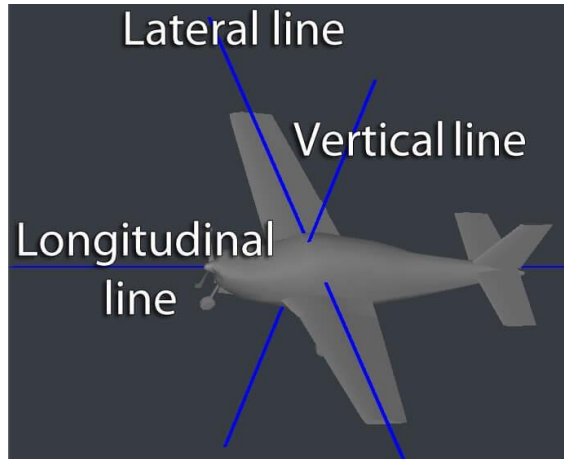

Figure 33 Calibration Line Locations

7.5.22.2.1 Adjusting Pitch

For installations in which the IFD system is not at a right angle with respect to the horizontal axis of the aircraft, the Pitch value will need to be adjusted. If the rear of the IFD (Faceplate side) is pitched down with respect to the horizontal axis of the aircraft, you will need to enter a negative number for the Pitch value. If the rear of the IFD (Faceplate side) is pitched up with respect to the horizontal axis of the aircraft, you will need to enter a positive number for Pitch.

7.5.22.2.2 Adjusting Roll

For installations in which the IFD system is not aligned with the lateral line of the aircraft, the roll value needs to be adjusted. If the IFD is tilted toward the left wing of the Aircraft, you will need to enter a negative number for the Roll value. If the IFD is tilted toward the right wing of the Aircraft, you will need to enter a positive number for the Roll value.

7.5.22.2.3 Adjusting Yaw

For installations in which the IFD system is not parallel to the longitudinal line of the aircraft, the yaw value will need to be adjusted. If the rear of IFD is skewed to the right of longitudinal line, then you will need to enter a positive number for the Yaw value. If the IFD is skewed to the left of longitudinal line, you will need to enter a negative number for the Yaw value.

7.5.22.3 Post Calibration Check

For IFD545/IFD550

Once you have entered all calibration values as desired, boot the IFD into flight mode. Power off the IFD for at least one minute. Turn the IFD back on after at least one minute and press the SVS button to display the synvis screen. The display should accurately reflect the aircraft

orientation. If this is not the case, readjust the Pitch, Roll and Yaw settings as described above in section 7.5.22 through 7.5.22.2.3.

For ATLAS:

Once you have entered all calibration values as desired boot the Atlas into flight mode. Power off the Atlas for at least one minute. Turn the Atlas back on after at least one minute powered off.

1. Reboot the Atlas into maintenance mode
2. Access the Config tab by pressing the right side of the AUX key.
3. Turn the outer right knob until you see the IRU Calibration page.

The IRU Calibration page should accurately reflect the aircraft orientation. If this is not the case readjust the Pitch, Roll and Yaw settings as described above in section 7.5.22 through 7.5.22.2.3

7.5.23 RDR2000 Radar Configuration

7.5.23.1 Configuration Module Setup

7.5.23.1.1 Primary Radar Setup

1. Power on the primary IFD in Maintenance Mode and select the Config/Radar Calibration page.
2. Press the "Radar" LSK, then place the radar into "Test"
3. Press the Diagnostics LSK to display the diagnostics page.
4. Press the Knob-Func LSK until "Gain" is selected
5. Turn the left inner knob counter-clockwise until 'Gain Pot' displays -31.0
6. Press the Knob-Func LSK until "Tilt" is selected
7. Turn the left inner knob clock-wise until the tilt setting is at its maximum value in the "Tilt Setting" field.
8. Press the Diagnostics LSK to return to the standard radar page.
9. Adjust the left outer knob to select a range of 240 NM.
10. Press the "Diagnostics" LSK to return to the diagnostics page. Six Yellow faults shall quickly flash several times and then "-none-" shall be displayed. This confirms that the radar has been placed into calibration mode.

7.5.23.2 Antenna Clearance Check

Set the Knob-Func LSK back to 'Gain' then turn the left inner knob clockwise to obtain a value between -26.5 and -28.0 in the "Gain Pot" field. This will initiate the antenna clearance scan. The antenna will move to each of the extreme positions to determine that there is no interference with the antenna movement and all scan motors are working properly.

7.5.23.3 Radar Stabilization (IFD545, IFD550, Atlas only) – Not Currently Supported

7.5.23.4 Calibrate Radar Pitch and Roll

1. Set the Knob-Func LSK to 'Roll Trim'.
2. Rotate the left inner knob to adjust the "Roll Trim" setting to "0.000°".
3. Level the aircraft.
4. Set the Knob-Func LSK to 'Gain' and rotate the left inner knob to obtain a value between -11 and -12. This will allow adjustment of the "Pitch Angle".
5. Set the "Pitch Angle" to 0.0° +/- 1.0 degrees as follows:
 - a. Set the Knob-Func LSK to 'Tilt'.
 - b. To increment the value of the "Pitch Angle" use the left inner knob to select a "Tilt Setting" between 5 and 10. When the "Tilt Setting" is between 5 and 10, the value of the "Pitch Angle" field will slowly increase.
 - c. To decrement the value of the "Pitch Angle" use the left inner knob to select a "Tilt Setting" between -5 and -10. When the "Tilt Setting" is between -5 and -10, the value of the "Pitch Angle" field will slowly decrease.
 - d. When the desired setting is reached, quickly adjust the "Tilt Setting" to above 10 or below -10 to "lock in" the setting.

6. Set the Knob-Func LSK to 'Gain' and rotate the left inner knob to obtain a value between -7 and -9. This will allow adjustment of the "Roll Angle".
7. Set the "Roll Angle" to 0.0° +/- 1.0 degrees as follows:
 - a. Set the Knob-Func LSK to 'Tilt'.
 - b. To increment the value of the "Roll Angle" use the left inner knob to select a "Tilt Setting" between 5 and 10. When the "Tilt Setting" is between 5 and 10, the value of the "Roll Angle" field will slowly increase.
 - c. To decrement the value of the "Roll Angle" use the left inner knob to select a "Tilt Setting" between -5 and -10. When the "Tilt Setting" is between -5 and -10, the value of the "Roll Angle" field will slowly decrease.
 - d. When the desired setting is reached, quickly adjust the "Tilt Setting" to above 10 or below -10 to "lock in" the setting.
8. To save the changes into the radar perform the following steps:
 - a. Set the Knob-Func LSK to 'Gain' and rotate the left outer knob to obtain a "Gain Pot" setting between -4 and -5.
 - b. The "Faults" field shall display "Gyro Input".
 - c. Set the Knob-Func LSK to 'Tilt' then change the "Tilt Setting" to its minimum value. The "Faults" field shall flash indicating that the calibrations settings have been saved. If the save procedure is successful, the "Gyro Input" fault will be removed and the "Scan Angle" will cycle through the entire number range. A "transmitter inhibit" fault shall be displayed in the "Faults" field.

7.5.24 Fixed Wing TAWS enablement and configuration

The Fixed Wing TAWS enablement is available for IFD5xx and Atlas units with software version 10.3.0.2 or later only. The enablement can be purchased via the dealer network from Avidyne Sales. You will receive a .dsf file upon purchase. This file should be loaded only to the #1 IFD in dual IFD installations.

7.5.24.1 Loading the DSF File

1. Ensure that the IFD is powered OFF.
2. Insert the USB flash device containing the .dsf file to be loaded
3. Power up the IFD.
4. If the IFD does NOT boot to Maintenance Mode:
 - a. In Flight mode, press the **AUX** key on the bezel.
 - b. Press the right side of the **AUX** key until the "SYS" tab is selected.
 - c. Press the LSK labeled "Select" until "Update Databases" is displayed.
 - d. Press "Update Databases" and "Confirm" and wait until the maintenance mode is displayed.
 - e. If necessary, press the left side of the **AUX** key until the "Update tab is displayed.

5. Twist the bottom right outer knob to highlight "Install XXXXX IFD Options" (XXXXXX represents the aircraft tail number).
6. Press the bottom right knob to select "Install XXXXX IFD Options".
7. Press "Proceed".
8. When complete, the system should display "All items completed with no error" at the top of the screen, and "OK" adjacent to item titled "Install XXXXX IFD Options".
9. Press the "Done" soft key to reboot the IFD into Flight Mode.

7.5.24.2 Enablement Verification

1. In Flight Mode, press the **AUX** key.
2. Press the left side of the **AUX** key until the "SYS" tab is selected.
3. Verify the TAWS option is highlighted green with white text. If options are not highlighted, contact [Avidyne Technical Support](#). Refer to section 7.6.18 of this manual for TAWS System Checkout

7.5.24.3 TAWS Enablement Requirements

1. To meet TSO requirements for TAWS-B, the TAWS AUDIO output from the *IFD5XX/Atlas* must be wired to an unswitched input on the aircraft audio panel. If the installation previously had ALERT Audio wired for FLTA purposes, no additional wiring for audio is required.
2. It is incumbent on the installing agency to determine if external annunciators are required for field of view considerations. For field of view requirements for external TAWS annunciators refer to section xxx of this manual. If necessary, the installation of the external annunciators will require separate approval. Refer to Figure D-26 of this manual for approved TAWS annunciator interfaces. The following annunciations are required if utilizing an external annunciators:
 - a) Terrain N/A
 - b) Terrain Pull Up
 - c) Terrain Caution
 - d) TAWS Inhibit

7.5.25 Stormscope Test Page

The Maintenance Mode Stormscope Test page is accessible from the Maintenance Mode Config Tab when one set of the RS232 ports has been configured as WX-500 and at least one power cycle has been executed since configuration.

Stormscope Test page contains the following LSKs: Change Mode, Strikes Clear, Get Data

Change Mode LSK - Changes to the Stormscope test mode as shown in the LSK. The mode selected will be returned by the WX-500 and will display within the strike display. Repeated presses of the Change Mode LSK will step through each of the modes, cycling back to the first mode in the list (Weather).

These are the Stormscope test modes:

- Weather - basically a fixed heading version of normal flight mode - will display real lightning strikes if any are generated.
- Noise - similar to Weather mode but with the WX-500 sensitivity set to determine where excess noise might be generated.
- Strike Test - a target displaying test strikes as generated by a WX-500 strike generating test set.
- Demo - similar to Weather mode with the strikes generated internally by the WX-500's Demo mode.
- Self-Test - executes the WX-500 internal Self-Test sequence which will return to Weather mode after 10 seconds.

Strikes Clear LSK - Pressing this LSK will send a "clear strikes" command to the WX-500, clearing its internal buffer of strikes.

Get Data LSK - Pressing the Get Data LSK will Download Data from the WX-500. The Stormscope Downloadable Data page will display ASCII data as retrieved verbatim from the Stormscope. Repeated presses of the Get Data LSK will step through each of the Downloadable Data modes, cycling back to the first mode in the list (SW Version).

These are the Stormscope Downloadable Data modes:

- SW Version - displays the WX-500 Main SW Version / Main Boot SW Version / DSP SW Version
- Config - displays the WX-500 configuration settings (Serial Jumpers, Hdg Valid Flag, Flag Sense, Hdg Value, Inhibit Line and Antenna Mount).
- Environment - displays the WX-500 environmental parameters (voltages and processor temp)
- Fault Log - displays the WX-500 fault log history of the last 20 faults.

7.5.26 GAD 42 Configuration

The IFD can be connected to the Garmin GAD42 Interface Adapter but there is no dedicated GAD42 configuration page in the IFD.

If the IFD is replacing a GNS530/W or GNS430/W that had previously been connected to a GAD42, then no action is required since the configuration is already saved in the GAD42.

If this is a new installation of an IFD (i.e. not replacing an existing GNS530/W or GNS430/W) or if the GAD42 had to be replaced for service, then the GAD42 must be configured via a manual strapping method as described in Garmin P/N 190-00159-00 GAD42 Installation Manual, Section 5.1.

If the IFD displays a “GAD 42 Needs Service” message, return the GAD 42 unit to the manufacturer.

7.5.27 Other System Diagnostics Pages

The IFD provides other miscellaneous diagnostics pages some of which are shown here for reference. Each page variant is accessed by pressing the L4 LSK labeled "Info" or turning the lower right outer knob.

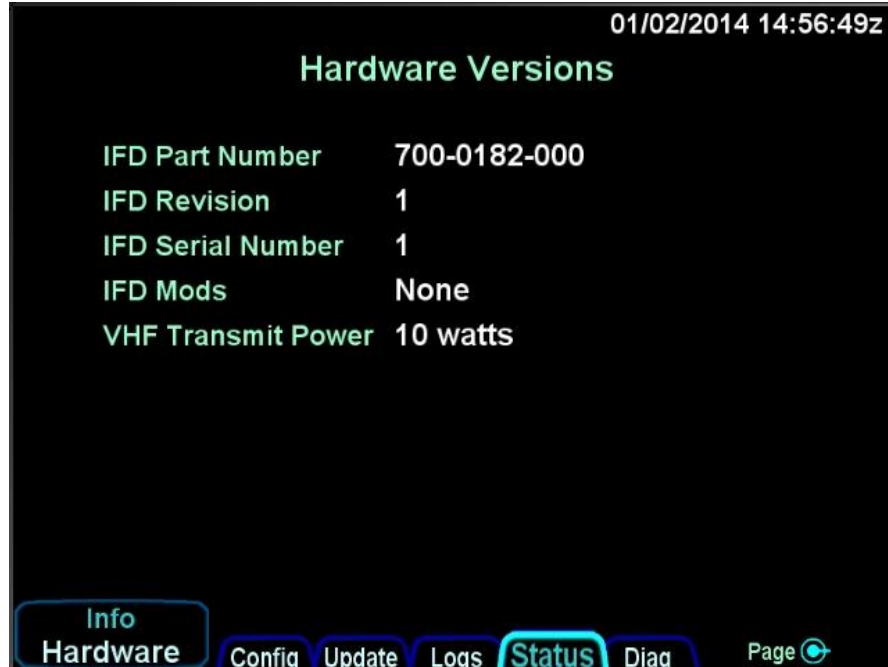

Figure 34 Hardware Version Page

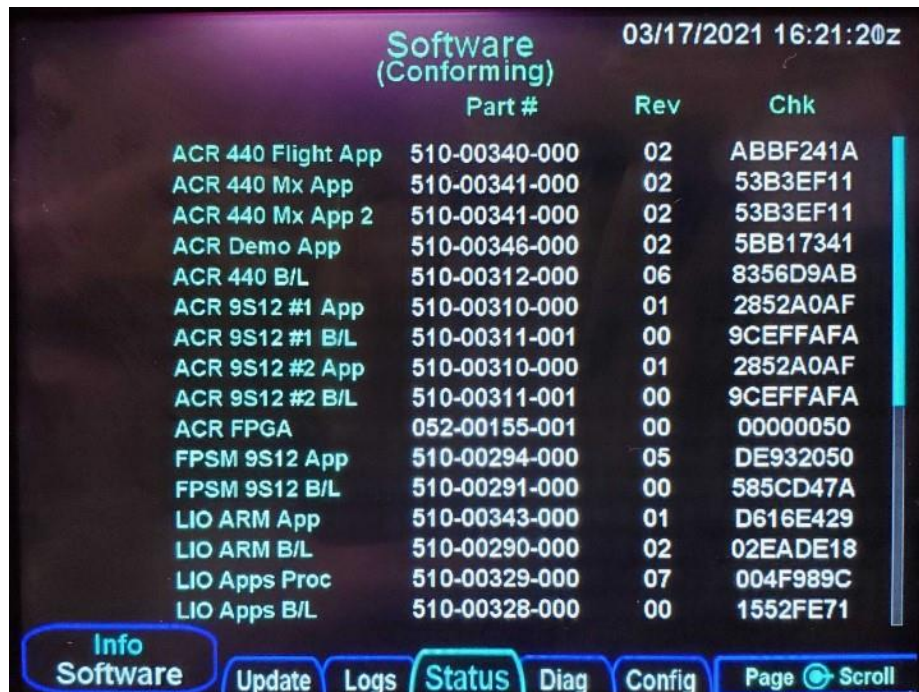

Figure 35 Software Version Page



Figure 36 Fan Status Page

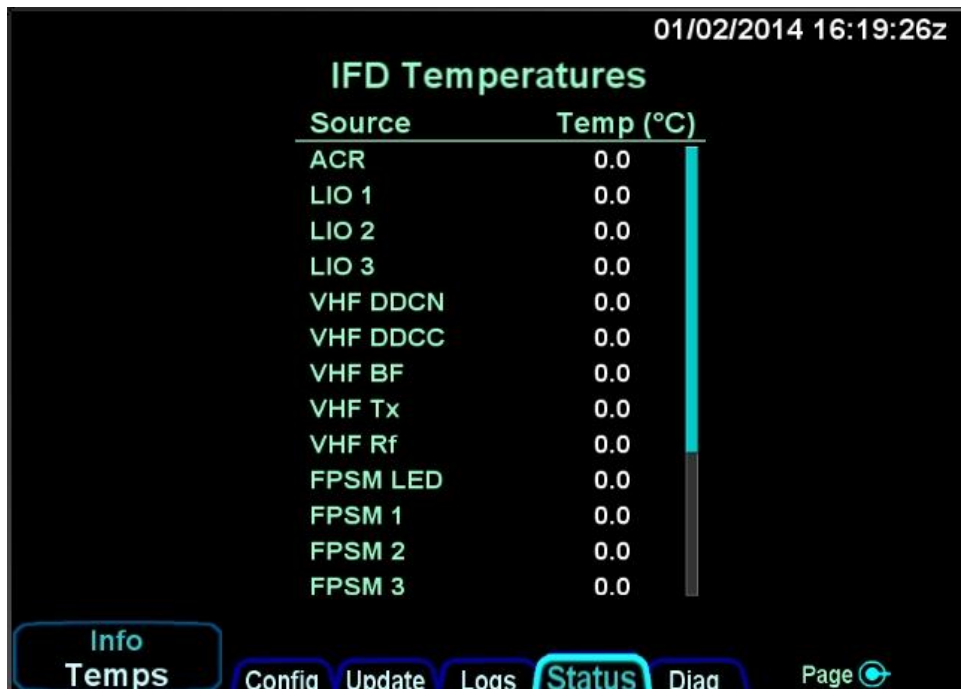

Figure 37 IFD Temperature Status Page

The pages on the “Diag” tab are for Avidyne Service Center diagnostics purposes and are not described in this manual.

7.6 Checkout

After configuring the IFD, the following post-installation tasks should be performed.

7.6.1 Database Check

Verify the Navigation, Chart, and Obstacle databases are up to date. If the databases need to be updated, reference the IFD Pilot's Guide or Section 10.1 for update procedures.

7.6.2 Airplane Flight Supplement Check

Complete and install the IFD Airplane Flight Manual Supplement in the aircraft's Flight Manual or Pilot's Operating Manual.

7.6.3 Instructions for Continued Airworthiness

Complete and install the IFD Instruction for Continued Airworthiness in the aircraft maintenance records.

7.6.4 Aircraft Weight and Balance

Update the Aircraft's Weight and Balance in the aircraft records.

For those installations where an IFD5XX/4XX is replacing a similar equipped GNS530 or GNS430 (a like variant) no weight and balance must actually be performed. If a GPS only Garmin unit is being replaced with a full featured IFD5XX/4XX, the weight change is more than one pound and a weight and balance must be prepared.

Since a full featured IFD5XX/4XX is within 5% of the weight of the removed GNS530/430 (less than 1 pound difference), no new weight and balance must actually be performed according to AC 43.13-1B Change 1 Acceptable Methods, Techniques, and Practices Aircraft Inspection and Repair (Chapter 10) and AC 120-27E Aircraft Weight and Balance Control.

7.6.5 Electrical Load Analysis

Verify the aircraft's electrical load is within limits, reference Section 4.10.

7.6.6 GPS Signal Acquisition

After installation, position the aircraft outside with clear unobstructed view of the sky. Verify the IFD acquires and calculates a GPS position. Verify no interference from other aircraft equipment is observed (e.g. TCAS, SATCOM, etc)

7.6.7 VHF COM Checkout

Note: This section is not applicable for IFD510/545/410.

7.6.7.1 VHF COM Interference

After installation, the VHF Communication should be tested. In 1 MHz increments between 118-136.000 MHz, transmit for 35 seconds on each frequency. Verify no interference between VHF Comm and other aircraft systems.

Evaluate the GPS system on the following frequencies. The GPS system should not experience complete signal loss on when transmitting on the VHF Comm.

25 kHz channels

- 121.150
- 121.175
- 121.200
- 131.250
- 131.275
- 131.300

8.33 kHz channels

- 121.185
- 121.190
- 130.285
- 131.290
-

7.6.7.2 VHF Antenna Checkout

Verify the VSWR is less than 2:1 through the entire frequency band. This can be verified using an aviation navigation test set (e.g. IFR 4000 or similar test equipment). VSWR higher than 2:1 will have reduced VHF Com performance. If >2:1 VSWR, verify in-flight performance is acceptable.

7.6.7.3 Receiver/Transmitter Operation

Test VHF Com's ability to receive and transmit to another VHF Com station. Verify using a low/middle/high frequency.

7.6.8 VOR/LOC/ GS Checkout

Note: This section is not applicable for IFD510/545/410.

If installed, test the VOR/LOC/GS system using a local frequency or test set. Verify the OBS (selected course) is functioning, CDI/HSI/PFD is indicating correctly, and NAV audio is received. Also, verify no EMI on the VOR/LOC/GS system.

7.6.9 Autopilot

If the IFD can be coupled to an Autopilot system, verify the Autopilot is operating correctly with the IFD as the navigation source.

7.6.10 Magnetic Compass Swing

After installation and EMI checks are complete, perform a magnetic compass “swing” in accordance with the aircraft maintenance manual for updating the heading correction card in accordance with 14 CFR 23.1327 and 23.1547.

7.6.11 IFD Bezel and Display Lighting

Verify the Bezel and Display Lighting for the IFD can be set to an appropriate level for Day and Night flight conditions. Likewise, verify any external HSI/CDIs can be properly adjusted for day and night lighting conditions.

7.6.12 External Annunciators and Switches

If installed, verify external annunciators and switches are operating correctly. Verify the external annunciator lighting can be adjusted for Day and Night flight conditions (Bright and Dim setting, but never off). Verify all external switches are functioning correctly.

7.6.13 Placards

Verify all circuit breaker(s), switches, and limitation placards (if needed) are installed.

If required per Section 2.1.1, there must be a placard in clear view of the pilot that specifies the kind of operations to which the operation of the airplane is limited or from which it is prohibited under 14 CFR 23.1525. The limitation placard must be installed in a conspicuous place in the Pilot's field of view. The placard text height must be a minimum of 0.10 inches in contrasting color to the surrounding area. The text must be high-quality solid-color font of at least 300 DPI (dots per inch). The placard must not be easily disfigured, erased, or obscured.

7.6.14 Self-test Page

For the duration that the notification of legal rights page is displayed during normal power up on the ground, all remote annunciator lamps are lit up and the system generates a specific set of electrical outputs for the purpose of self-test and troubleshooting. The table below defines the outputs transmitted during this time.

Parameter	Self-test Value
Course Deviation	Half-scale left deviation, TO indication, flag stowed
Glideslope/Vertical Deviation	Half-scale up deviation, flag stowed
Annunciators	All on
Bearing to Waypoint (RMI)	135°
Selected Course (OBS)	150° when interfaced to an HSI with course pointer
Desired Track	150°
Distance To Go	10.0 NM
Time To Go	4 minutes
Active Waypoint	“AVDYN”
Groundspeed	150 knots
Present Position	N39°04.05', W094°53.86'
Waypoint Alert	Active
Phase of Flight	Enroute

Parameter	Self-test Value
Message Alert	Active
GPS Integrity	Invalid
Roll Steering (if applicable)	Flight Director commands 0° bank (level flight) for 5 seconds; commands increasing right bank at 1°/second for 5 seconds; commands 5° right bank for 5 seconds; commands decreasing right bank at 1°/second for 5 seconds, until command is 0° bank again. This cycle repeats continuously.

Table 142 Self-test Output

7.6.15 Dual IFD Configuration

If installing two IFD units, verify duplex communication between the two units. Reference Section 3.3.8 and 7.3 for limitations and configuration.

7.6.16 Heading Interface Check

Verify the IFD is receiving heading information from an external source. This can be verified on the Main Input Page in maintenance mode, reference Section 7.5.6. If power is removed from the external heading source, the Main Input Page will display dashed lines for heading. Note: If the IFD is connected to a Primary Flight Display, it must be turned off before performing this check.

7.6.17 ADS-B Output

If the IFD is connected to ADS-B out transponder, verify the position information transmitted is correct per 14 CFR 91.227. Also, if using the IFD for transponder Mode-C altitude information, verify the transponder is using the correct altitude source from the IFD, reference Section 6.12.

7.6.18 Fixed Wing TAWS Checkout (if enabled)

7.6.18.1 TAWS System Self-Test

1. Press the **AUX** key on the bezel.
2. Press the left side of the **AUX** key until the "SYS" tab is selected.
3. Press the LSK labeled "Select" until "GPS" is displayed.
4. Ensure "SBAS" is displayed beside "NAV MODE".

Note:

TAWS operation, to include the internal self-test, is dependent upon the IFD achieving SBAS. TAWS will have no functionality in any other GPS state. GPS antennas must have a clear line of sight with the sky in an open area to achieve SBAS. It can take the IFD three to four minutes to achieve SBAS.

5. Press the left side of the **AUX** key until the “AUDIO” tab is selected.
6. Twist the bottom right outer knob to highlight “Aural Alert”.
7. Use the bottom right inner knob to adjust the “Aural Alert” volume output.
 - a. The volume should be adjusted so that audible alerts can be clearly heard in a noise intensive environment (i.e., Engine(s) running).
8. Press the **MAP** key on the bezel.
9. Press the left side of the **MAP** key until the “TAWS” tab is selected.
10. On the TAWS screen, press the **SELF TEST** button.
11. Listen for the aural annunciation “TAWS System Test OK”, this indicates the system has passed.

7.6.18.2 TAWS System Failure Mode Test

1. Ensure the TAWS System is operational per the test listed in 7.6.18.2
2. Block the GPS reception by any means available
3. Once the IFD GPS signal is degraded, verify the IFD issues a TAWS FAIL CAS message along with an aural chime
 - a. If external annunciators are installed, the TAWS NOT AVAILABLE light should come on at this time.
 - b. Acknowledging the CAS message by pressing the CAS message on the screen, or by pressing the CLR line select key will cancel the aural alert chime.
4. GPS degradation can be determined by receiving a GPS degraded CAS message on the IFD or manually by validating any GPS state other than SBAS is presented beside “NAV MODE” on the GPS status page.
5. Once the system has appropriately failed, allow the GPS to regain SBAS by removing the blocking apparatus
6. Ensure the TAWS Fail Annunciation clears

7.6.18.3 TAWS External Annunciator Test (If Installed)

The TAWS Annunciators will illuminate during the IFD start-up test.

Individual TAWS annunciators can also be tested separately via the Main Discrete Toggles in maintenance mode (See section 7.5.8 of this manual).

8. Flight Checks

The IFD must be flight tested to verify the installation is operating properly. The following items should be tested in flight to verify the IFD function.

8.1 GPS Verification

Verify the following in flight:

- Verify the GPS reception during all phases of flight. (e.g., bank angles of up to 30 degrees and pitch angles associated with take-off, departures, landing and missed approaches)
- Verify the following GPS/FMS operation:
 - Hold at a designated waypoint
 - Intercept and track to or from a waypoint on a selected course
 - Waypoint sequencing
 - Verify the overall operation of procedures or paths
 - Selection of an approach
- Evaluate the display of navigation parameters on the flight instruments (PFD, HSI, CDI) is correct
- Verify annunciation is correct and in the Pilot's field of view

8.2 VHF COM Flight Check

Note: This section is not applicable for IFD510/545/410.

Verify in-flight the IFD VHF communication transceiver in the high, mid, and low frequency ranges. Verify the VHF at least 50 nautical miles and at an appropriate altitude.

8.3 VOR Flight Checks

Note: This section is not applicable for IFD510/545/410.

Verify in-flight the IFD VHF navigation receiver by tuning a local VOR station within 50 nautical miles. Verify the audio tone is heard and course deviation information and flag information are correct.

8.4 ILS Flight Checks

Note: This section is not applicable for IFD510/545/410.

Verify in-flight the IFD VHF navigation receiver by tuning an airport with an ILS. Verify the NAV ID audio tone is heard and the course deviation and flag information are correct.

8.5 Autopilot Checks

Verify the IFD interface to the autopilot is correct. Reference the Autopilot Manual installation/maintenance manual for test procedures. Verify the following functions:

- Evaluate the steering response while in Flight Director (FD) and when the autopilot is coupled
- Execute several fly-by-turns with varying wind conditions for the FD and autopilot
- Evaluate the autopilot's response to a GNSS fault (e.g., pulling the IFD Circuit Breakers)

8.6 Sensors Verification

Verify the IFD interface to other aircraft sensors are operating correctly (e.g., Traffic, Lightning, Weather, etc).

8.7 Fixed Wing TAWS Checks (if enabled)

Verify the IFD TAWS system passes self-test. Ensure that on approach, the pilot is able to easily hear and clearly discern the “500 ft Callout”

9. Glove Validation Procedures

Many types of gloves can be used with the IFD touch screen display. The key parameter for the effectiveness of a glove with touch screen is the distance between the finger and the glass and to a lesser extent, the type of material separating the skin from the glass. The thinner the glove or the more compatible the material (e.g. leather, fine cotton, etc), the greater the likelihood of success will be. Likewise, the more surface area that comes in contact with the glass, the greater the success may be. Each glove must be qualified for compatibility with the display and those glove calibration procedures (specific to the glove and the pilot combination) are immediately below. If all verification steps are marked as a "Pass" then the glove/pilot combination is considered to be a qualified pair.

Pilot Name		
Description of Glove		
Verification Step	Circle	one
Touch the standby frequency window and verify a virtual keyboard is displayed.	Pass	Fail
Type 121.7, press the "ENTER" button on the virtual keyboard and confirm 121.700 is the displayed frequency in the #1 Standby Com window.	Pass	Fail
Press each of the page tabs displayed on the present page and verify the IFD changes to the selected tab.	Pass	Fail
With the FMS FPL tab displayed, use touch to type in a typical flight plan and verify that all entries were recognized.	Pass	Fail
With the Map page and tab displayed, attempt to pan the map.	Pass	Fail
With the Map page and tab displayed, attempt to pinch zoom (in or out) the map to produce a range change.	Pass	Fail
With the Map page and tab displayed, attempt to graphically flight plan ("rubber band") and verify the intended change was made.	Pass	Fail
Press the "Freq" function key on the bezel and then double tap a frequency from the list to place it into the #1 standby slot.	Pass	Fail

Table 143 Glove Validation Procedure

10. Software and Database Update Procedures

10.1 Data Updates

Periodic updates to navigation data, charts data, and obstacle data are all made through the USB port on the front of each IFD. Updates must be performed in accordance with 14 CFR Part 43, Appendix A (c) and FAA AC 20-153() paragraph 11.

The table below summarizes the databases update periods:

Database	Update Cycle	Comments & Source
Chart Data	14 days	Expiration watermark displayed after 14 days indefinitely until data updated (Jeppesen) (N/A for IFD4XX)
Nav Data	28 days	Airport, airway, navaid, airspace, and FMS data (Jeppesen)
Obstacle Data	56 days	Displayed on map and used for TA and FLTA functions (Jeppesen)
Terrain Data	As required	Displayed on map and used for TA and FLTA functions. The IFD is shipped from the factory with this database already loaded and updates are anticipated to be a rare occurrence.

Table 144 Database Update Cycle

In the event the terrain data ever needs updating, this is also performed through the front panel USB port.

Use one of the formatted fobs supplied by Avidyne (marked by the Avidyne logo printed on one side). In the event one of those fobs are not available, either call Avidyne for a replacement fob (a nominal fee will be charged) or purchase a replacement through other means. Most USB drives that can be formatted using FAT32 will be acceptable.

To perform a data update, ensure the data to be updated is placed onto one of the acceptable USB fobs. Carefully insert the USB fob into the IFD USB slot while power is turned off. When the IFD is powered up it should start in maintenance mode. If the IFD does not start in maintenance mode, select the "Setup" tab of the SYS page and then pick the "Update Databases" LSK.

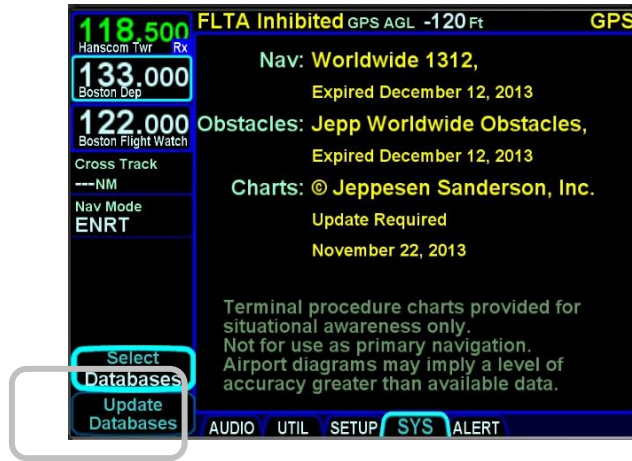

Figure 38 Update Databases LSK

You will be prompted to “Confirm” or “Cancel”. Assuming you selected “Confirm”, you should see a dialog box presented in the middle of the screen and all uploadable files on that fob will be individually listed and check marks may be visible next to each file name.

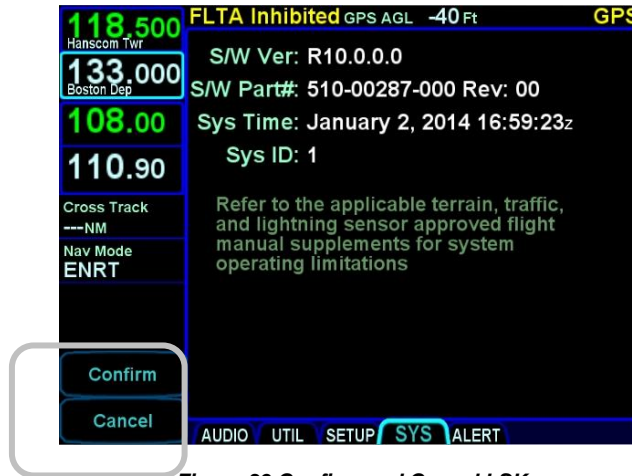

Figure 39 Confirm and Cancel LSK

Use the “Select All”, “Un-select All” LSKs and the lower right IFD knob twist to scroll and push to select as required to ensure check marks are associated with all the desired files to upload to the IFD. Now press the “Proceed” LSK to begin the file upload.



Figure 40 LSK Options

A progress bar will be presented to help provide an idea of how much longer the upload will take.

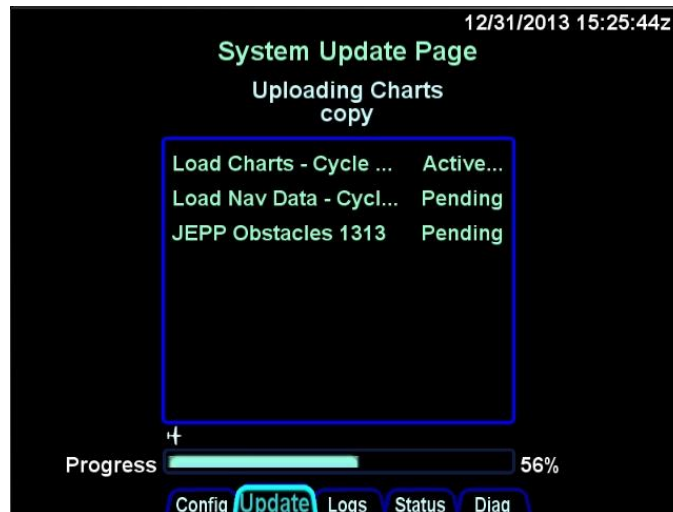

Figure 41 Progress Bar

Typical upload times are:

- Worldwide Obstacles (1.5 MB) – 5 sec
- Eastern US Charts (100 MB) – 3 min
- US Charts (180 MB) – 5 ½ min
- Worldwide Charts (430 MB) – 13 min
- US Nav Data (8 MB) – 3 ½ min
- Europe Nav Data (10 MB) – 2 ½ min
- Australian Nav Data (1.5 MB) – 30 sec
- Worldwide Nav Data (15 MB) – 7 Min

For multiple IFD installations, the database uploads must be performed individually for each IFD to be updated.

Due to some of the upload durations, Avidyne recommends creating a fob for each IFD to be updated so that the updates can happen in parallel and not stacked serially, thereby extending the overall time to accomplish a full update.

A clear indication is presented when the data uploads have been completed. Likewise, if the USB fob was removed prior to finishing the data upload, an error message will be presented and the entire process will need to be manually restarted once the fob is reinserted in the IFD.

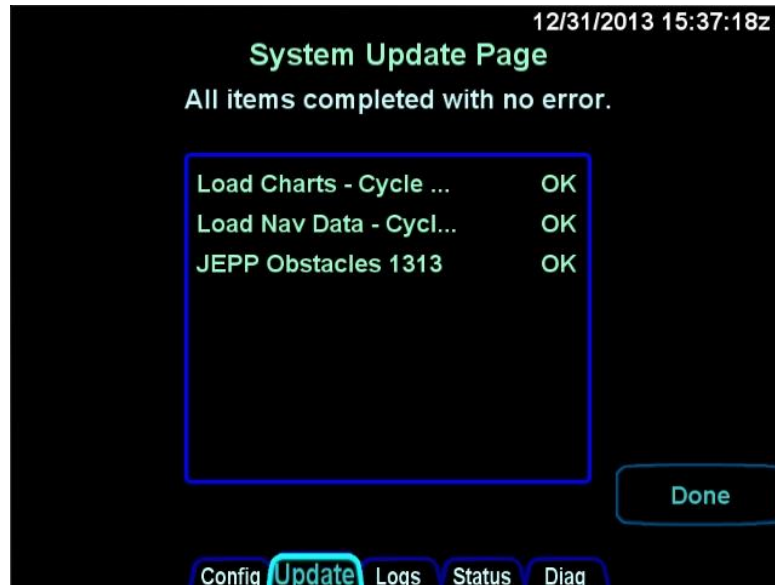

Figure 42 Update Complete Indication

When you are all done press the “Done” LSK, which will restart the IFD into flight mode. Remove the USB fob and perform a normal start up. It is highly recommended to verify the data was updated from the “Setup” LSK of the SYSTEM tab on the AUX page.

If an IFD is in normal operating mode (not maintenance mode), the presence of a USB fob is ignored.

10.2 Datalogs Download

There is extensive data-logging that is automatically done on all IFDs. These datalogs can be accessed post-flight and used for a number of purposes.

There are five types of datalogs employed in the IFDs:

- **System Log** - This log provides an in-depth record of the navigation state. From this log, you can re-create many aspects of the FMS output and IFD state. It logs at a rate of approximately 1Hz.
- **Flight Log** - This log provides a detailed record of your aircraft state as measured by the various IFD sensors. It logs at a rate of approximately 5Hz.

- **Engine Log** - This log provides details on fuel flow sensor data (if configured). It logs at a rate of approximately ¼ Hz.
- **Event Log** - This log contains miscellaneous data such as all alerts, keystrokes, flight plan data, system status and error messages, etc. It is designed to be diagnostics log for Avidyne Service Center technicians and not expected to be used by owners/operators. It logs at an on-condition rate.
- **Voltage Log** - This log contains internal diagnostic data such as the voltages and currents on sub-system boards, temperatures and internal fan status. It logs at a rate of approximately 1Hz.
- **Download Configuration Info** - This log contains the system configuration for the unit.
- **GPS Log** - This log contains detailed internal state data for the GPS.

The “Download Logs” LSK is presented when “Software” is selected on the SYS tab and the system is not in-air. When the “Download Logs” LSK is pressed, a pair of Confirm/Cancel LSKs are presented. Selecting Confirm will launch the Maintenance Mode of the IFD. From Maintenance Mode, press the right side of the AUX page function key to select the “Logs” tab. Ensure a USB fob is inserted in the IFD front bezel USB port and then use a combination of the left side LSKs and the bottom right IFD knob to select the desired combination of logs and type of action to perform.

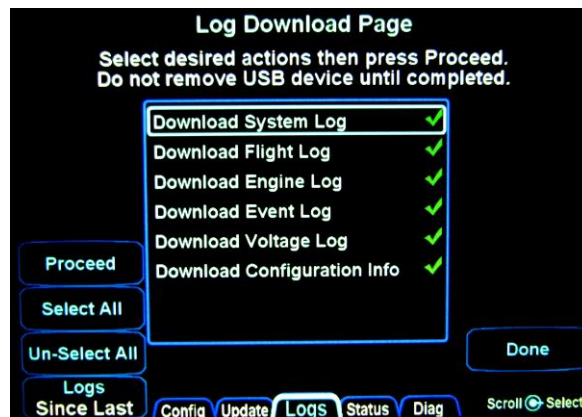

Figure 43 Datalogs Download Page

Pressing the “Proceed” LSK will immediately start downloading all logs listed in the center of the page with green check marks adjacent to them. If only a subset of the logs are to be downloaded, use the “Un-Select All” LSK to deselect all logs and then use the bottom right IFD knob to highlight the desired log and push in to generated a green check mark.

The “Logs” LSK on that Maintenance Mode page provides two options for downloading this data via dedicated LSKs. The first option (“Since Last”) downloads the data logged since the last time a download was completed. Since the logs contain a large amount of data, the Since Last option will be a quicker option in almost every case. The second option (“Full”) allows a download of all data logs onto the USB fob. The Full option can take up to 45 minutes to an hour to complete.

Download times are highly dependent on the number and types of logs being downloaded and how long it's been since the last download and whether you are downloading Since Last or Full. Times can range from a few seconds to more than 45 minutes. The more often logs are downloaded, the shorter the download times will be.

In order to provide an indication of download progress, a progress bar will be presented with both a symbolic aircraft indicating download in progress and a % complete estimate. The files to be downloaded can have one of several states - "OK", "In progress...", "Pending", "Skipped", "Active", "Failed".

When downloaded to the USB fob, the data logs will be saved in .csv files. This can be imported into newer versions of Microsoft Excel into a table format. The data can then be plotted or analyzed by several 3rd party tools. Note that files can easily contain 50MB or more of data.

10.3 Software Update

The following procedures should be followed when performing optional or mandatory software change to the IFD System:

1. Acquire the software image and associated loading procedure from the manufacturer.
2. Verify the software part number configuration before and after maintenance is performed on the airborne equipment using the loading procedure instructions.
3. It is the responsibility of maintenance personnel to ensure the identified part is recorded in the necessary maintenance logs.
4. It is the maintenance personnel's responsibility to ensure that the software part identification has been logged. When new software is loaded into the unit, the correct software part number should be verified according to the instructions accompanying the software change before the unit is returned to service. Hardware versions are identified on the data label by a Rev number following the main part number.

Changes to software part number, version, and/or operational characteristics should be reflected in the Operator's Manual, Aircraft Flight Manual, Aircraft Flight Manual Supplement, and/or any other appropriate document.

11. Periodic Maintenance

The IFD does not require any periodic or preventative maintenance. Maintenance on the IFD is on condition.

11.1 Equipment Calibration

The IFD has no required servicing tasks.

11.2 VOR Checks

Every 30 days, verify the limits of the VOR per 14 CFR §91.171. Only required for IFR operations. (N/A for IFD510/545/410 and Atlas FMS Only units)

11.3 Cleaning

The front display and bezel may require cleaning periodically, reference Section 13.

12. Factory Service Policies and Procedures

12.1 Technical Support

Avidyne's website contains information that may assist the operator and installer with questions or problems with their Avidyne IFD5XX/IFD4XX/ATLAS. Technical support questions may be submitted, via the following:

- Email: techsupport@avidyne.com
- Fax: 321-751-8435
- Voice: 1-888-723-7592 Toll Free USA.
- Voice +1-321-751-8520 Option 3 Outside the USA
- Internet: www.Avidyne.com
- Dealer Knowledge Base*<https://techsupport.avidyne.com/home/>

* Caution, Verify with this document that all of the devices shown in the Dealer Knowledge Base are FAA approved to interface with the IFDXXX or Atlas series of navigators.

Please include the part number, revision number and serial number of the unit in all correspondences. For problem reporting, please provide as many details associated with the problem as possible.

An Avidyne Technical Support Representative will respond as soon as possible. Avidyne business hours are: Monday through Friday: 8:00 AM to 5:00 PM Eastern Time
For After Hours AOG Technical Support, is available via the following:
AOG Support: 877-900-4AOG (4264)

12.2 General Service Procedures

Repair of the IFD/Atlas are performed at the authorized Part 145 service center located at the Avidyne factory.

Prior to returning a unit for service, contact Avidyne at , techsupport@avidyne.com or 1-888-723-7592 to obtain a Return Merchandise Authorization (RMA) number.

When calling or emailing for product-related help, please have the following information available:

1. Customer Name/ Account Information
2. IFD Serial Number. This number is displayed on the Software Status page available on the SYS tab. See image below. Alternatively, the number is printed on the TSO label of the IFD unit.

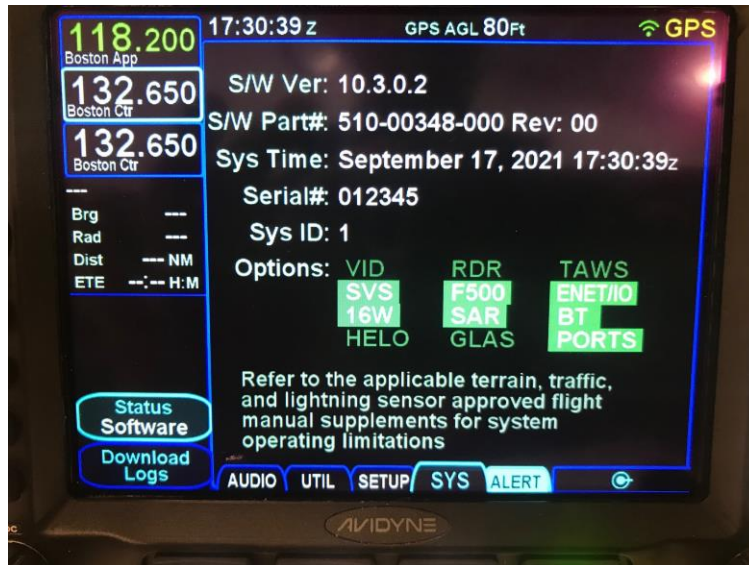

3. IFD Software Part Numbers: Press the "AUX" page function key and then tab over to the "SYS" tab. Record the "Software Version" and the "Flight Software Part Number". Also make a note of any other yellow text on that page.
4. Be prepared to download the aircraft flight logs and email/transmit them to Avidyne Technical Support.

13. Bezel and Display Cleaning

If the IFD screen should become dirty due to fingerprints or dust, clean the screen using the following materials and methods:

A clean, soft lint-free cloth such as 3M Ultra-Brite Cloth #2011 or similar.

A cleaning solution composed of a 1:1 ratio of de-ionized water and isopropyl alcohol (IPA). Use caution, as it may be flammable. Always apply the cleaning solution directly on the cloth. Never spray cleaner directly on the screen.

In general, isopropyl alcohol is a safe and effective cleaner. Methanol and most acidic solutions can be toxic or damaging to glass coatings if misused.

Excessive or unnecessary cleaning should be avoided to prevent damage to the coated optical filter surfaces. Never allow excess amounts of cleaning agents to dry if they have formed into pools, streaks or droplets to help avoid spotting of the glass surface.

The use of any 3rd party screen protector, especially those that adhere directly to the IFD display glass, is not endorsed by Avidyne due to the touch-screen nature of the display and may void the warranty for any display related issue.

Appendix A: Environmental Qualification Form

IFD540, IFD510, IFD440, IFD410

Environmental Tests	RTCA/DO-160G Section	Test Category
Temperature and Altitude	4.0	
Low Temp	4.5.2	Equipment qualified to Category C1
High Temp	4.5.3 & 4.5.4	Equipment qualified to Category C1
In-Flight Loss of Cooling	4.5.5	Equipment qualified to Category W
Altitude	4.6.1	Equipment qualified to Category C1
Decompression	4.6.2	Equipment qualified to +55,000 Ft.
Overpressure	4.6.3	Equipment qualified to -15,000 Ft.
Temperature Variation	5	Equipment qualified to Category B
Humidity	6	Equipment qualified to Category A
Operational Shocks & Crash Safety	7	Equipment qualified to Category E
Vibration	8	Equipment qualified to Category S, Curves B and M, Category U, Curve G
Explosive Atmosphere	9	Category X, no test performed
Waterproofness	10	Category X, no test performed
Fluids Susceptibility	11	Category X, no test performed
Sand and Dust	12	Category X, no test performed
Fungus Resistance	13	Category X, no test performed
Salt Spray	14	Category X, no test performed
Magnetic Effects	15	Equipment qualified to Class Z
Power Input	16	Equipment qualified to Category B
Voltage Spike	17	Equipment qualified to Category A
Audio Frequency Conducted Susceptibility	18	Equipment qualified to Category B
Induced Signal Susceptibility	19	Equipment qualified to Category ZC
Radio Frequency Susceptibility	20	Equipment qualified to Category W (conducted)/WR (radiated)
Emission of Radio Frequency Energy	21	Equipment qualified to Category M
Lightning Induced Transient Susceptibility	22	Category B4HZL4 (Power) and B3K4L4 (All other I/O)
Lightning Direct Effects	23	Category X, no test performed
Icing	24	Category X, no test performed
Electrostatic Discharge	25	Equipment qualified to Category A
Fire and Flammability	26	Category X, no test performed

Table 145 Environmental Qualification Form - IFD540/510/440/410

IFD550, IFD545

(Low Temp and Vibration Categories Differ From Table 145)

Environmental Tests	RTCA/DO-160G Section	Test Category
Temperature and Altitude	4.0	
Low Temp	4.5.2	Equipment qualified to Category X (non-standard category) Equipment tested to C1 with Ground Survival Low limited to -40C
High Temp	4.5.3 & 4.5.4	Equipment qualified to Category C1
In-Flight Loss of Cooling	4.5.5	Equipment qualified to Category W
Altitude	4.6.1	Equipment qualified to Category C1
Decompression	4.6.2	Equipment qualified to +55,000 Ft.
Overpressure	4.6.3	Equipment qualified to -15,000 Ft.
Temperature Variation	5	Equipment qualified to Category B
Humidity	6	Equipment qualified to Category A
Operational Shocks & Crash Safety	7	Equipment qualified to Category E
Vibration	8	Equipment qualified to Category S, Curves B and M
Explosive Atmosphere	9	Category X, no test performed
Waterproofness	10	Category X, no test performed
Fluids Susceptibility	11	Category X, no test performed
Sand and Dust	12	Category X, no test performed
Fungus Resistance	13	Category X, no test performed
Salt Spray	14	Category X, no test performed
Magnetic Effects	15	Equipment qualified to Class Z
Power Input	16	Equipment qualified to Category B
Voltage Spike	17	Equipment qualified to Category A
Audio Frequency Conducted Susceptibility	18	Equipment qualified to Category B
Induced Signal Susceptibility	19	Equipment qualified to Category ZC
Radio Frequency Susceptibility	20	Equipment qualified to Category W (conducted)/WR (radiated)
Emission of Radio Frequency Energy	21	Equipment qualified to Category M
Lightning Induced Transient Susceptibility	22	Category B4HZL4 (Power) and B3K4L4 (All other I/O)
Lightning Direct Effects	23	Category X, no test performed
Icing	24	Category X, no test performed
Electrostatic Discharge	25	Equipment qualified to Category A
Fire and Flammability	26	Category X, no test performed

Table 146 Environmental Qualification Form - IFD550/545

ATLAS

Environmental Tests	RTCA/DO-160G Section	Test Category
Temperature and Altitude	4.0	
Low Temp	4.5.1 & 4.5.2	Equipment qualified to Category X (non-standard category) Equipment tested to C1 with Ground Survival Low limited to -40C
High Temp	4.5.3 & 4.5.4	Equipment qualified to Category C1
In-Flight Loss of Cooling	4.5.5	Equipment qualified to Category W
Altitude	4.6.1	Equipment qualified to Category C1
Decompression	4.6.2	Equipment qualified to +55,000 Ft.
Overpressure	4.6.3	Equipment qualified to -15,000 Ft.
Temperature Variation	5	Equipment qualified to Category B
Humidity	6	Equipment qualified to Category A
Operational Shocks & Crash Safety	7	Equipment qualified to Category E
Vibration	8	Equipment qualified to Category S, Curves B and M, Category H, Curve R
Explosive Atmosphere	9	Category X, no test performed
Waterproofness	10	Category X, no test performed
Fluids Susceptibility	11	Category X, no test performed
Sand and Dust	12	Category X, no test performed
Fungus Resistance	13	Category X, no test performed
Salt Spray	14	Category X, no test performed
Magnetic Effects	15	Equipment qualified to Class Z
Power Input	16	Equipment qualified to Category B
Voltage Spike	17	Equipment qualified to Category A
Audio Frequency Conducted Susceptibility	18	Equipment qualified to Category B
Induced Signal Susceptibility	19	Equipment qualified to Category ZC
Radio Frequency Susceptibility	20	Equipment qualified to Category W (conducted)/WR (radiated)
Emission of Radio Frequency Energy	21	Equipment qualified to Category M
Lightning Induced Transient Susceptibility	22	Category B4HZL4 (Power) and B3K4L4 (All other I/O)
Lightning Direct Effects	23	Category X, no test performed
Icing	24	Category X, no test performed
Electrostatic Discharge	25	Equipment qualified to Category A
Fire and Flammability	26	Category X, no test performed

Table 147 Environmental Qualification Form - Atlas

Appendix B: STC Permission

Avidyne Corporation hereby grants to all National Aviation Authorities (FAA, CAA, JAA, etc) approved installers the use of data from STC SA00343BO (Part 23 Aircraft) or STC ST00411BO (Part 25 Aircraft) to install the Avidyne IFD5XX / ATLAS System. This also includes any international validations of the STC (e.g. EASA, ANAC, etc). Copies of the STC data are available on the Avidyne Dealer Website or upon request. The latest data revisions are listed in Avidyne 700-00182-XXX/700-00179-XXX Master Document List, AVIFD-306 STC SA00343BO (Part 23 Aircraft), or AVIFD-568 STC ST00411BO (Part 25 Aircraft)

Installers must abide by the conditions and limitations stated in both the STC and in the Installation Manual in order to maintain compliance. The use of this data by itself does not constitute installation approval.

Appendix C: Mechanical Drawings

Figure C - 1 IFD5XX Tray Installation201
 Figure C - 2 IFD4XX Tray Installation202
 Figure C - 3 IFD5XX Instrument Panel Cutout.....203
 Figure C - 4 IFD4XX Instrument Panel Cutout.....204
 Figure C - 5 Atlas Physical Dimensions205
 Figure C - 6 Typical GPS Antenna Installation.....206
 Figure C - 7 AT-575 GPS Antenna Hole Pattern.....206
 Figure C - 8 AV-801 GPS Antenna Hole Pattern207
 Figure C - 9 Typical GPS Antenna Doubler Installation208
 Figure C - 10 Typical GPS Antenna Doubler209

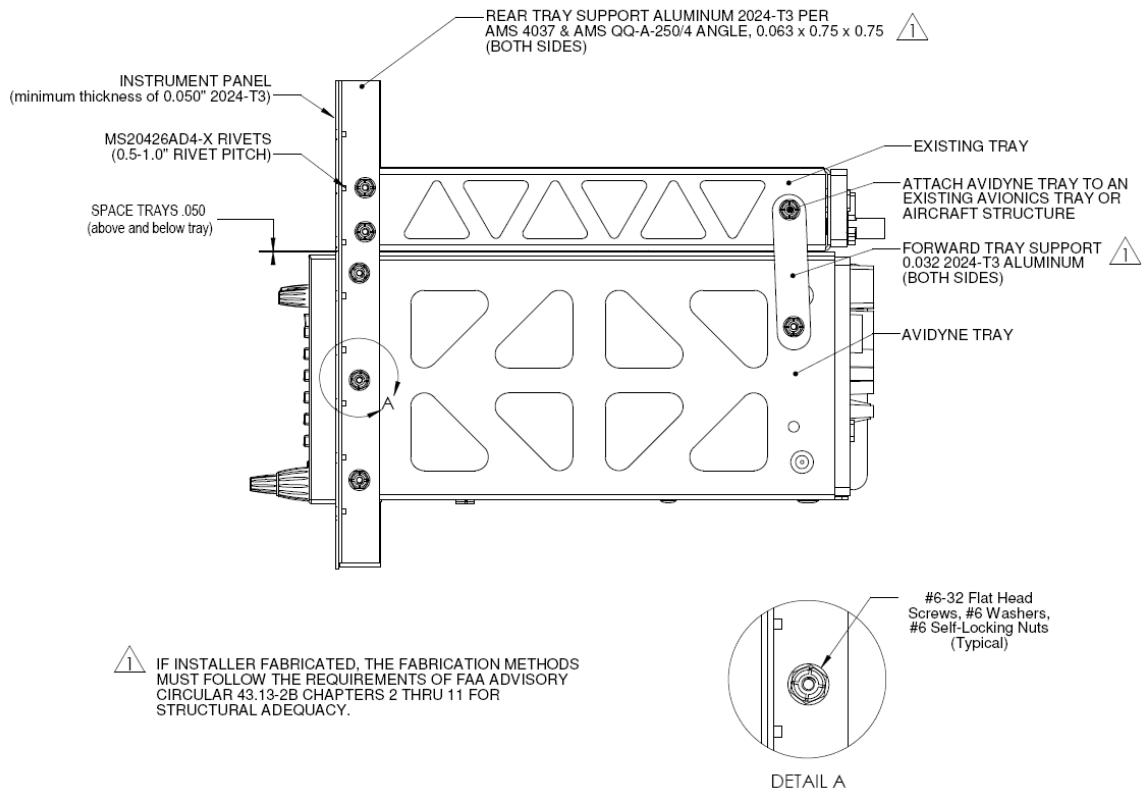

Figure C - 1 IFD5XX Tray Installation

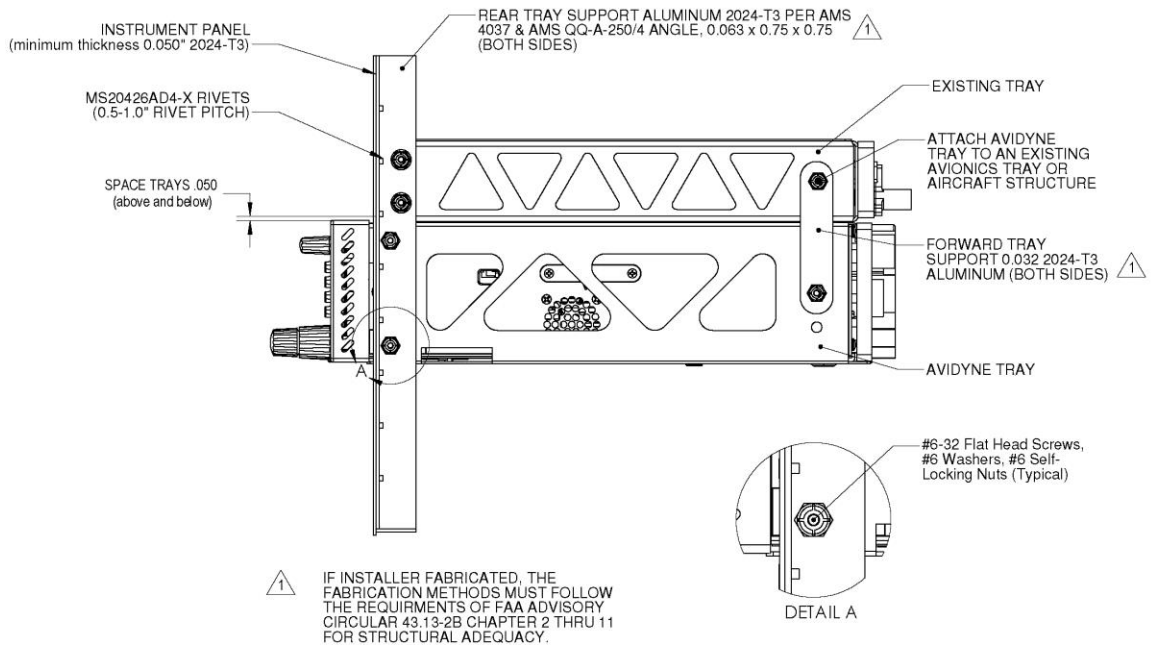
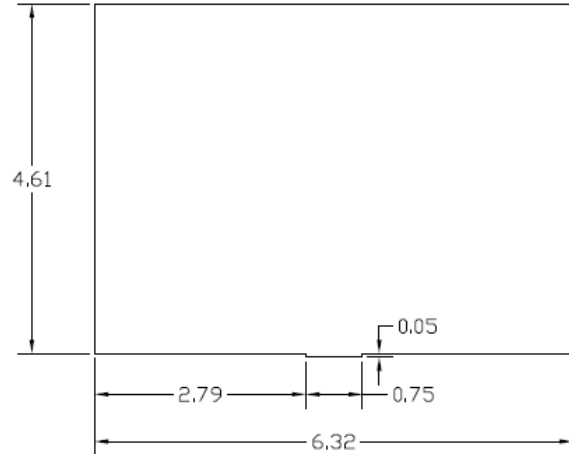

Figure C - 2 IFD4XX Tray Installation

INSTRUMENT PANEL CUTOUT
 UNIT INSTALLED FROM THE FRONT OF
 INSTRUMENT PANEL



INSTRUMENT PANEL CUTOUT
 UNIT INSTALLED FROM THE REAR OF THE
 INSTRUMENT PANEL
 MAXIMUM PANEL THICKNESS .125 INCHES

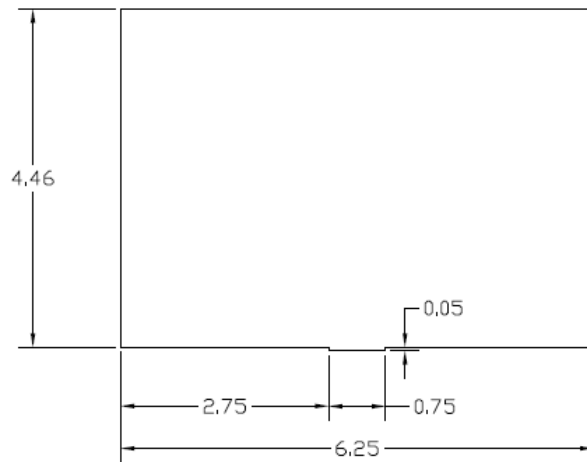
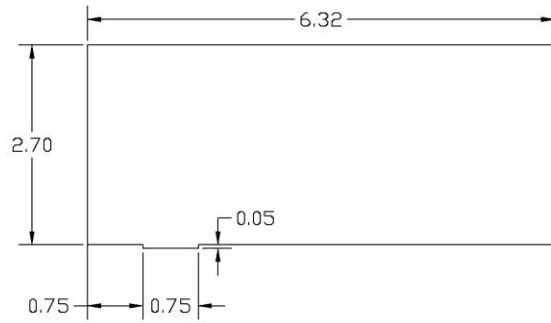

Figure C - 3 IFD5XX Instrument Panel Cutout

INSTRUMENT PANEL CUTOUT
UNIT INSTALLED FROM THE FRONT OF
INSTRUMENT PANEL



INSTRUMENT PANEL CUTOUT
UNIT INSTALLED FROM THE REAR OF THE
INSTRUMENT PANEL
MAXIMUM PANEL THICKNESS .125 INCHES

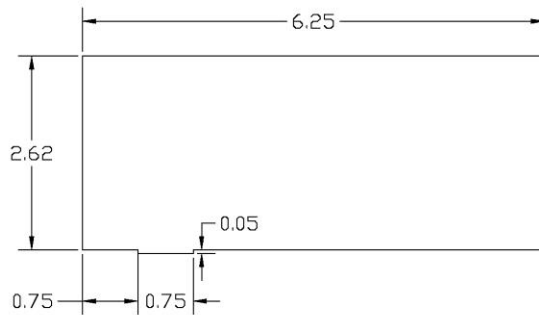

Figure C - 4 IFD4XX Instrument Panel Cutout

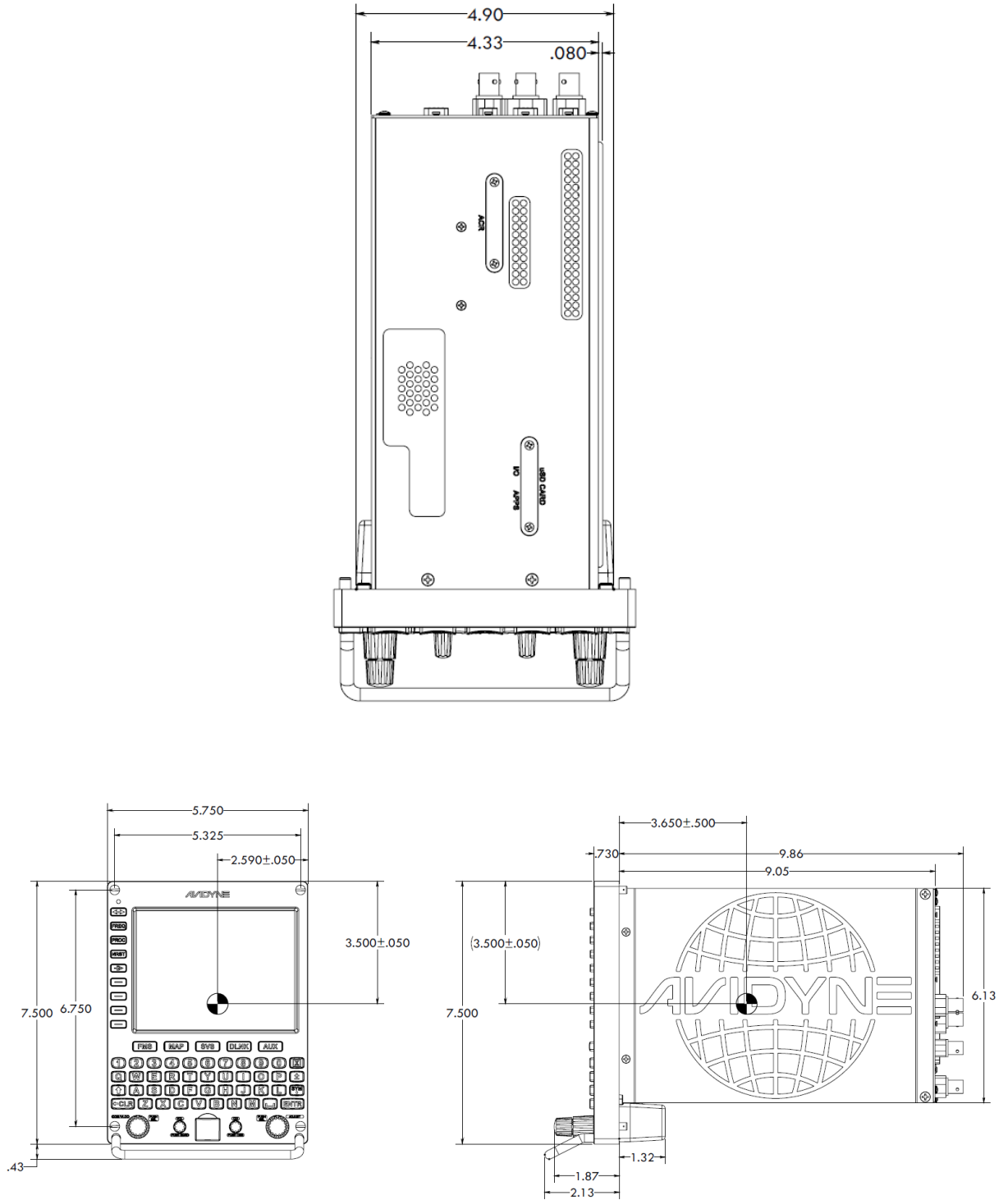

Figure C - 5 Atlas Physical Dimensions

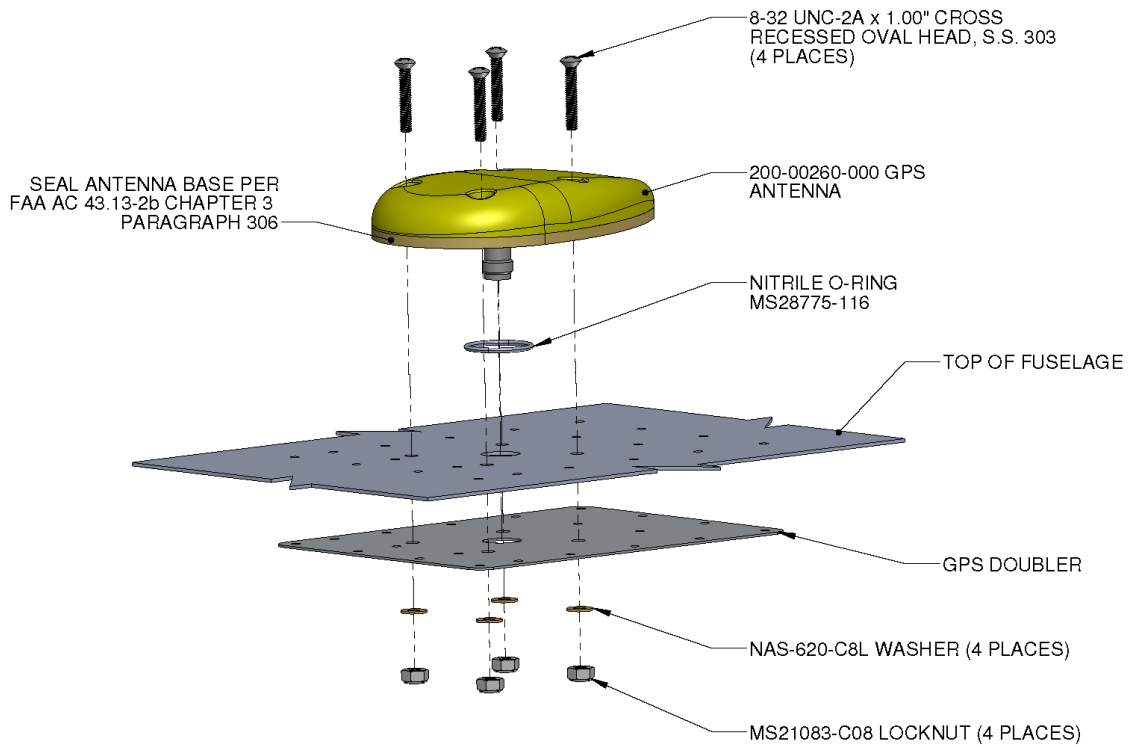

Figure C - 6 Typical GPS Antenna Installation

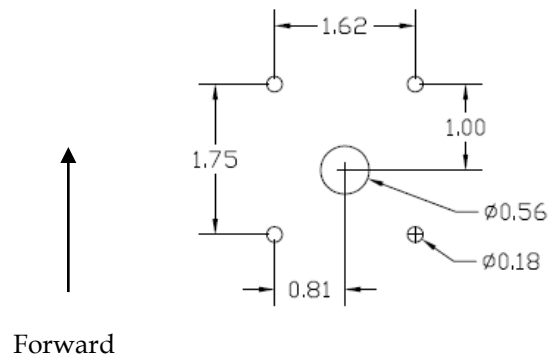
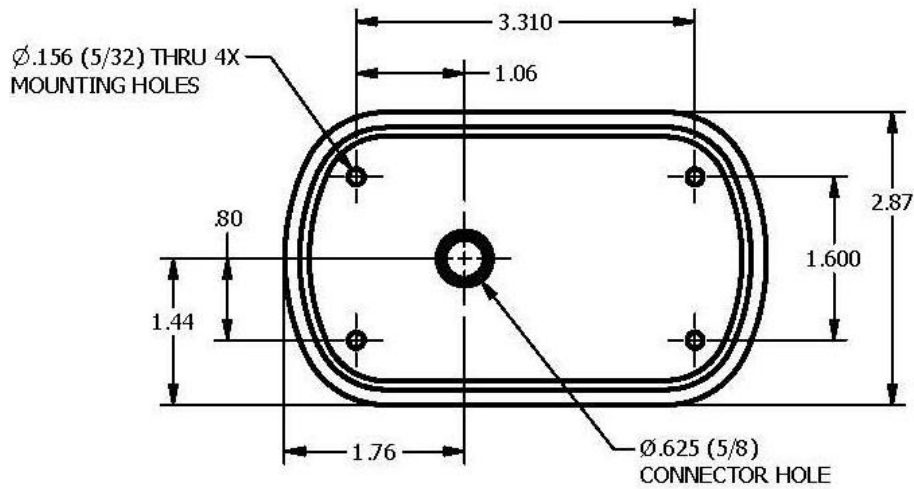
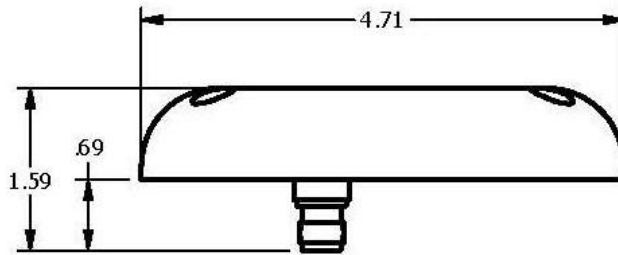
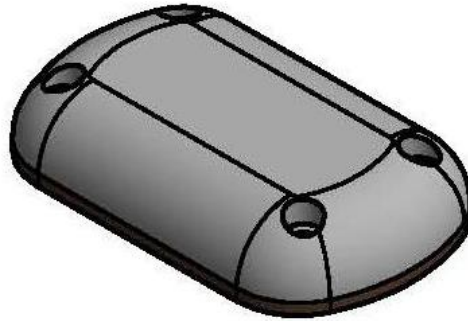

Figure C - 7 AT-575 GPS Antenna Hole Pattern



MOUNTING DETAIL

Figure C - 8 AV-801 GPS Antenna Hole Pattern

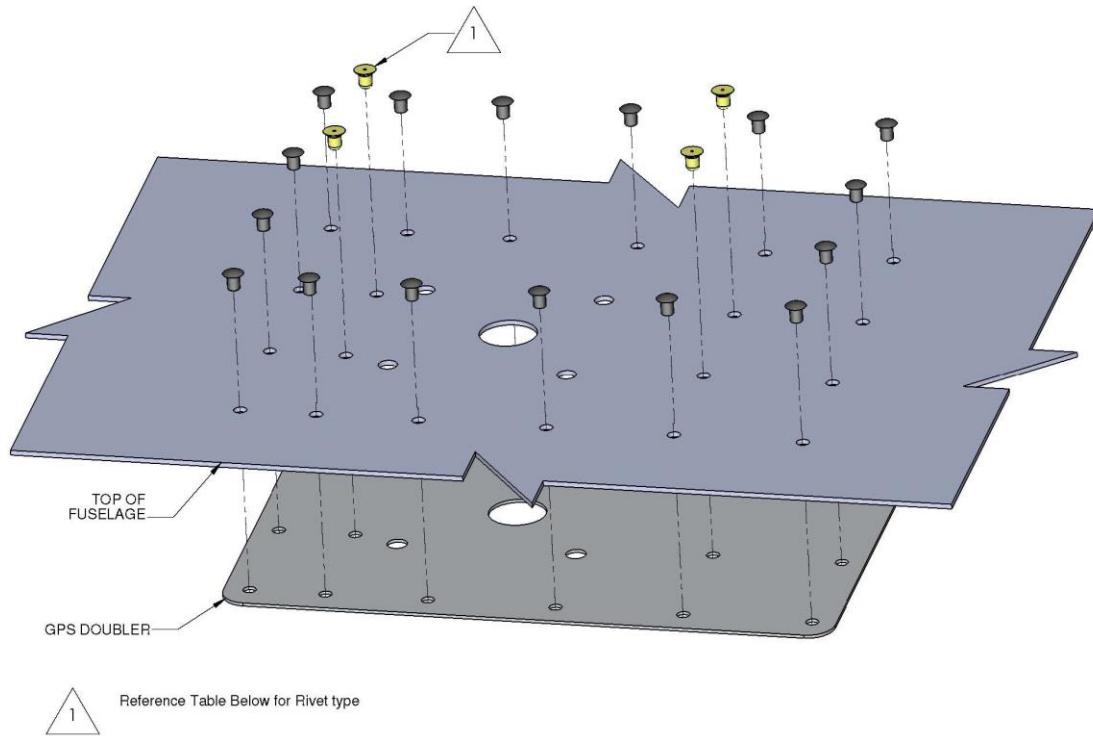

Figure C - 9 Typical GPS Antenna Doubler Installation

Fuselage Skin Thickness	Adjacent Structure ‡ Rivet Type	Doubler Thickness	Outer Rivet Row in Doubler	Inner Four Rivet in Doubler
0.016" - 0.025"	<i>Dimpled skin / Countersunk Rivets</i>	0.020"	<i>MS20426AD3 (Double Dimple)</i>	<i>MS20426AD3 (Double Dimple)</i>
0.016" - 0.025"	<i>Protruding Head Rivets</i>	0.020"	<i>MS20470AD3</i>	<i>MS20426AD3 (Double Dimple)</i>
0.032" - 0.050"	<i>Countersunk Skin / Countersunk Rivets</i>	0.032"	<i>NAS1097AD4 (Countersunk)</i>	<i>NAS1097AD4 (Countersunk)</i>
0.032" - 0.050"	<i>Protruding Head Rivets</i>	0.032"	<i>MS20470AD4</i>	<i>NAS1097AD4 (Countersunk)</i>

Table 148 Rivet/ Doubler Selection

‡ Rivet type is dependent on the type of rivets in the adjacent fuselage structure. If the adjacent rivets in the structure around the bay selected for the doubler installation are protruding head type, install MS20470AD rivets in the outer row of the doubler. If the adjacent rivets are countersunk or dimpled, install either MS20426AD or NAS1097AD rivets per the table above.

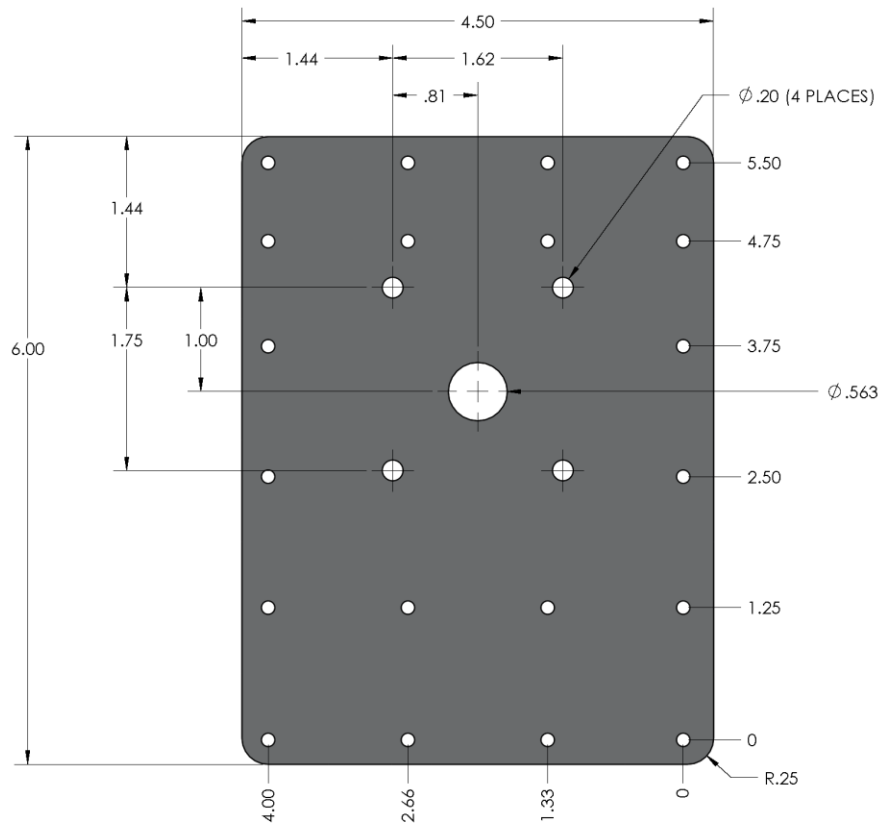

Figure C - 10 Typical GPS Antenna Doubler

Appendix D: Electrical Interface Drawings

Figure D - 1: Lighting, Power, and Antenna Interconnect.....	213
Figure D - 2: Blind Altitude Encoders Interconnect.....	216
Figure D - 3: RS-232 Serial Data Interconnect.....	217
Figure D - 4: EFIS Interconnect.....	219
Figure D - 5: Generic EFIS Interconnect.....	220
Figure D - 6: EHSI ARINC 429 Interconnect, Dual IFD5XX/4XX, Sandel SN3308 Interconnect..	221
Figure D - 8: ARINC 429/RS-232 Air Data/IRU/ AHRS Interconnect.....	223
Figure D - 9: Sandel SN3500 Interconnect.....	225
Figure D - 10: Traffic Advisory Interconnect.....	226
Figure D - 10: Traffic Advisory Interconnect.....	227
Figure D - 12: GTX 330 Interconnect.....	229
Figure D - 13: Terrain and Weather Interconnect.....	230
Figure D - 14: Weather Interconnect.....	231
Figure D - 15: Audio Panel Interconnect.....	232
Figure D - 16: VOR/ILS Indicator Interconnect.....	234
Figure D - 17: Main Indicator Interconnect.....	235
Figure D - 18 Main Indicator KI209 Interconnect.....	237
Figure D - 19: Main Indicator KI208A Interconnect.....	237
Figure D - 20: Main Indicator MD200-20X/ -30X Interconnect.....	238
Figure D - 21: RMI/OBI Interconnect.....	239
Figure D - 22: King Serial DME Tuning Interconnect, Panel Mount.....	240
Figure D - 23: King Serial DME Tuning Interconnect, Remote Mount.....	241
Figure D - 24: Parallel DME Tuning Interconnect.....	242
Figure D - 25: Parallel DME Tuning Interconnect.....	243
Figure D - 26: TAWS Interconnect.....	244
Figure D - 27: Autopilot Interconnect.....	245
Figure D - 28: Bendix/King Autopilot Interconnect.....	246
Figure D - 29: Century Autopilot Interconnect.....	247
Figure D - 30: Century Autopilot Interconnect.....	248
Figure D - 31: S-Tec Autopilot Interconnect.....	249
Figure D - 32: Collins Autopilot Interconnect.....	251
Figure D - 33: Bendix King KFC400 Autopilot Interconnect.....	252
Figure D - 34: External Navigation Source and GPS Annunciators Interconnect.....	253

Figure D - 35: Switch Interconnect	255
Figure D - 36: Garmin GAD 42 Interconnect	256
Figure D - 37: Garmin G600 Interconnect.....	257
Figure D - 38: Avidyne Entegra Interconnect	258
Figure D - 39: Avidyne EX500/600/5000 Interconnect	259
Figure D - 40: Aspen EFD1000 Interconnect (without ACU).....	260
Figure D - 41: Aspen EFD1000 Interconnect (with ACU)	261
Figure D - 42: Transponder Interconnect	262
Figure D - 43: ELT Interconnect.....	263
Figure D - 44: Skytrax100B/200 (formerly MLB100) ADS-B IN Receiver Interconnect.....	264
Figure D - 45: RDR2000 Interconnect.....	265
Figure D - 46: RDS Radars Interconnect	266
Figure D - 47: RDR2100/2060 Interconnect.....	267
Figure D - 48: MK VI and VIII EGPWS Interconnect	268
Figure D - 49: MK V, V-A, and VII EGPWS Interconnect	269
Figure D - 50: GTX 335 Interconnect	270
Figure D - 51: GTX 345 Interconnect	271
Figure D - 52: GTX 330ES Interconnect.....	273
Figure D - 53: Garmin GTX 3000 Interconnect.....	274
Figure D - 54: Avidyne AXP322 Interconnect.....	275
Figure D - 55: Avidyne Dual AXP322 Interconnect	276
Figure D - 56: NXT 700 MST70B Transponder Interconnect	277
Figure D - 57: Becker BXT 65XX Interconnect.....	278
Figure D - 58: FreeFlight FDL 978RX Interconnect	279
Figure D - 59: GDL 88 Interconnect.....	280
Figure D - 60: Avidyne AXP340 Interconnect.....	281
Figure D - 61: XMD076 Interconnect.....	282
Figure D - 62: Single GDU700/1060 PFD Interconnect	283
Figure D - 63: Dual GDU700/1060 PFD Interconnect	284
Figure D - 64: Garmin G5 EHSI Interconnect	285
Figure D - 65: Garmin G5 EADI Interconnect.....	286
Figure D - 66: Garmin G5 EFIS Interconnect.....	287
Figure D - 67: NGT9000R Interconnect.....	288
Figure D - 68: KT-74 Interconnect.....	289
Figure D - 69: TDR-94 Interconnect.....	290

Figure D - 70: Garmin GI-275 Interconnect291

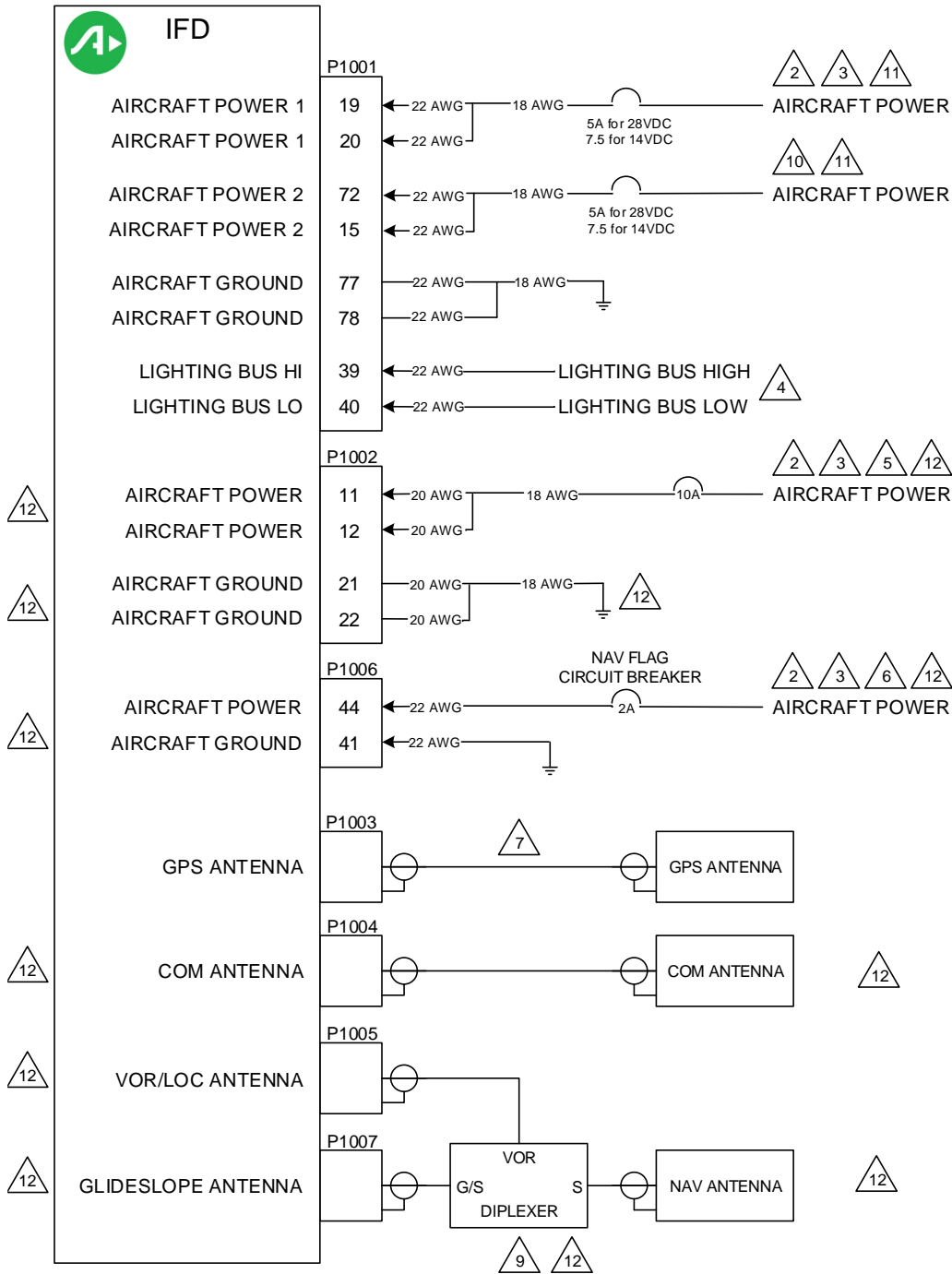

Figure D - 1: Lighting, Power, and Antenna Interconnect

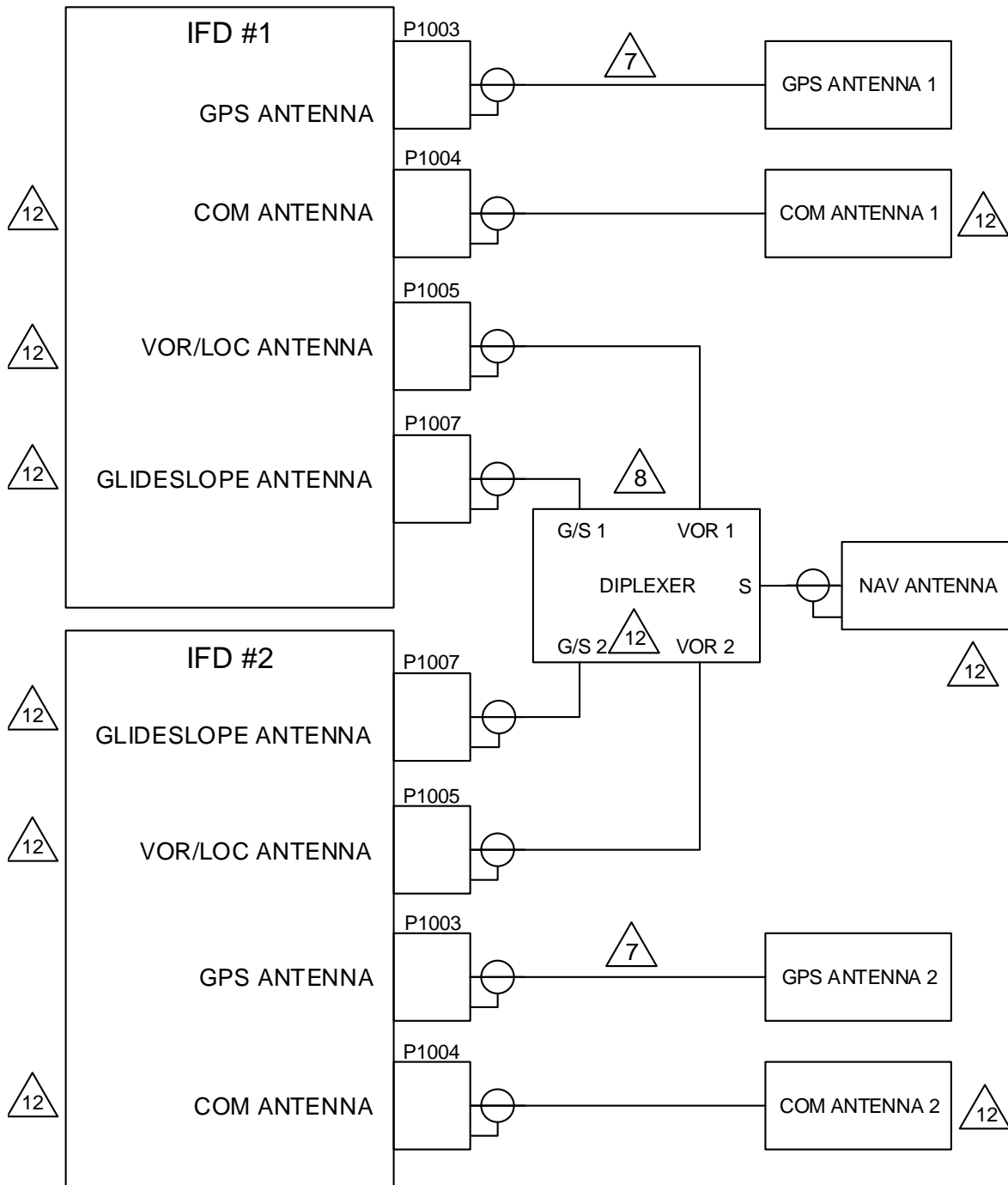
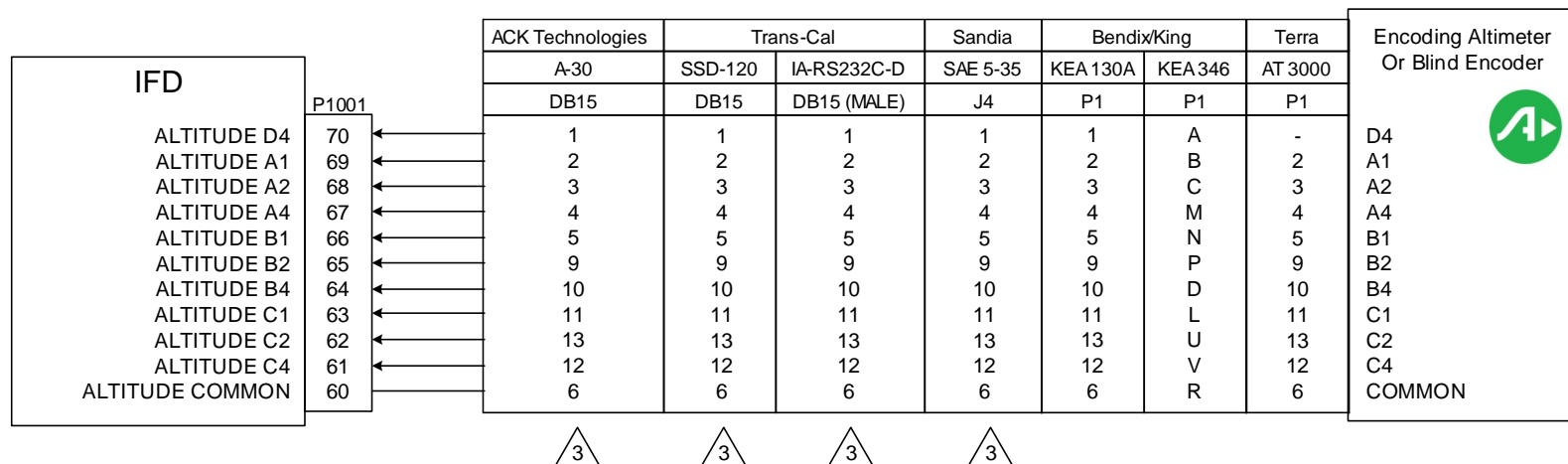

Figure D - 1: Lighting, Power, and Antenna Interconnect

NOTES:

1. ALL WIRES TO BE 24 AWG OR GREATER UNLESS OTHERWISE NOTED.
2. IF AIRCRAFT HAS MULTIPLE POWER BUSES, IT IS RECOMENDED THAT IFD/ATLAS POWER CONNECTIONS BE CONNECTED AS DESCRIBED IN SECTION 4.
3. AIRCRAFT POWER INPUT TO THE IFD MAY BE 9-33 VDC.
4. THE IFD SHOULD BE CONFIGURED FOR THE CORRECT LIGHTING BUS VOLTAGE POST-INSTALLATION. NO DAMAGE WILL OCCUR IF THE UNIT IS CONFIGURED INCORRECTLY. IN ADDITION, LIGHTING CAN BE SET TO AUTOMATICALLY COMPENSATE FOR AMBIENT LIGHTING CONDITIONS USING ITS LIGHT SENSOR. A MANUAL LIGHTING CONTROL OPTION IS ALSO AVAIABLE. REFER TO THE POST-INSTALLATION CONFIGURATION PROCEDURE. **LIGHTING BUS INPUTS ARE NOT DIFFERENTIAL. LIGHTING BUS LOW MUST BE TIED TO GROUND IN ALL CASES. FAILURE TO ADHERE TO THIS WILL RESULT IN DAMAGE TO THE IFD/ATLAS..**
5. MAXIMUM ALLOWABLE WIRE GAUGE INTO P1002 PINS IS 20 AWG. top
6. THE AIRCRAFT POWER INPUT P1006-44 PROVIDES POWER FOR THE VOR/LOC SUPERFLAG (P1006-15) AND GLIDESLOPE SUPERFLAG (P1006-38) OUTPUTS. NO POWER CONNECTION IS REQUIRED ON P1006-44 IF THESE FLAG OUTPUTS ARE NOT USED.
7. THE GPS ANTENNA COAXIAL CABLE MUST BE DOUBLE OR TRIPLE SHIELDED AND THE LOSS (INCLUDING CONNECTORS) MUST BE GREATER THAN 1.5 dB AND LESS THAN 6.5 dB.
8. COMMANT CI1125 DIPLEXER, OR EQUIVALENT, SHOULD BE USED.
9. COMMANT CI507 DIPLEXER, OR EQUIVALENT, SHOULD BE USED.
10. ACFT PWR 1 IS INTERNALLY DIODE ISOLATED FROM ACFT PWR 2. ONLY ONE POWER INPUT IS REQUIRED FOR NORMAL OPERATION.
11. FOR THE MAIN POWER INPUT, A 14VDC INSTALLATION REQUIRED TWO AIRCRAFT POWER IPUTS AND TWO AIRCRAFT GROUND CONNECTIONS BE USED FOR EACH MAIN POWER INPUT USED. A 28VDC INSTALLATION REQUIRES A MINIMUM OF ONE POWER AND GROUND CONNECTION, BUT TWO ARE RECOMMENDED.
12. NOT APPLICABLE FOR IFD410/510/545, or Atlas FMS Only units

Figure D - 1: Lighting, Power, and Antenna Interconnect Page 3 of 3



NOTES:

1. ALL WIRES TO BE 24 AWG OR GREATER UNLESS OTHERWISE NOTED.
2. REFER TO MANUFACTURER'S DOCUMENTATION FOR COMPLETE PINOUT AND INTERCONNECT INFORMATION.



THIS ENCODER MAY ALSO BE CONNECTED VIA RS-232.

Figure D - 2: Blind Altitude Encoders Interconnect

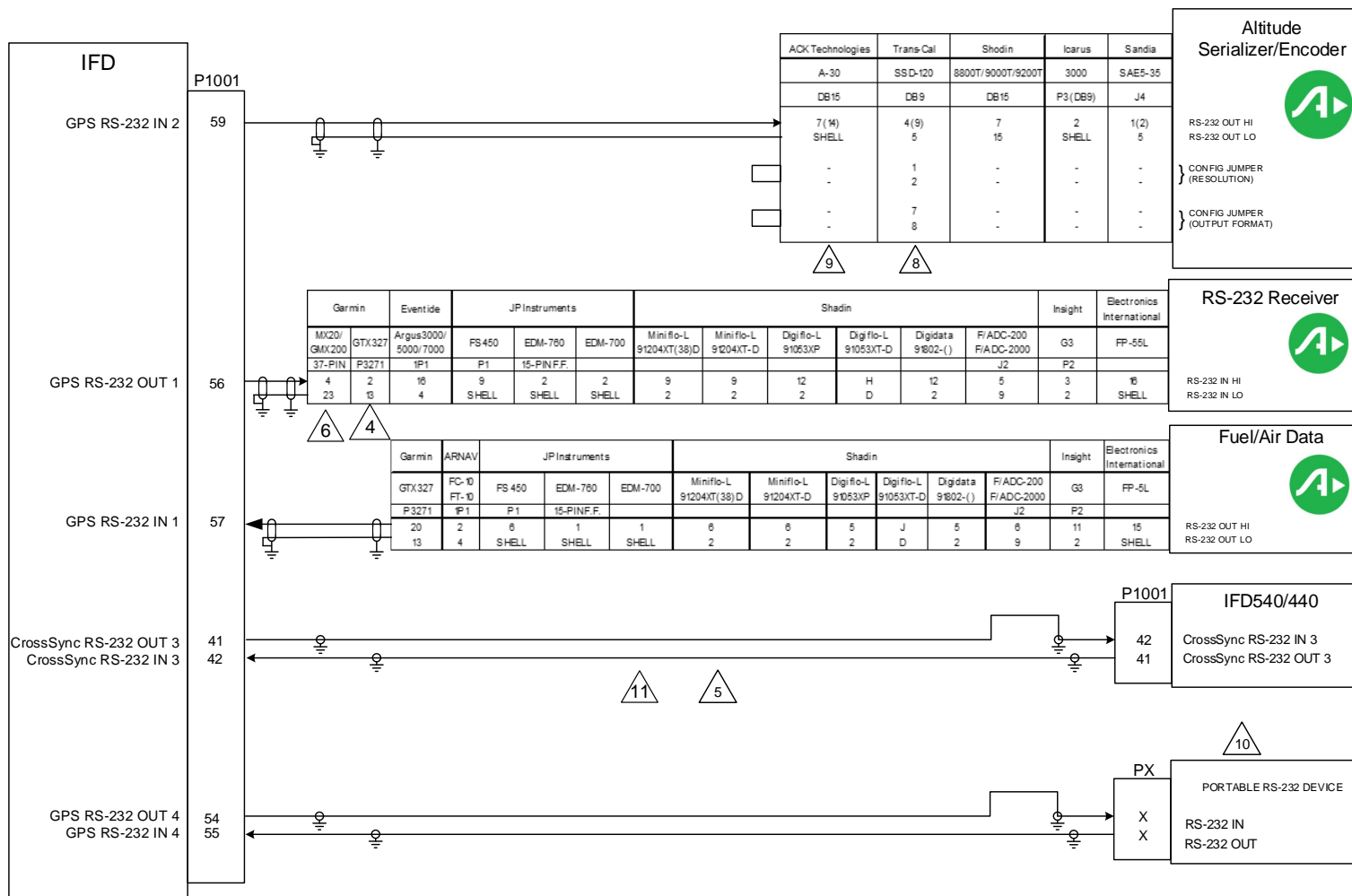

Figure D - 3: RS-232 Serial Data Interconnect

NOTES:







1. ALL WIRES TO BE 22 AWG OR GREATER UNLESS OTHERWISE NOTED.
2. AT IFD UNIT, TERMINATE SHIELD GROUNDS TO THE CONNECTOR BACKSHELL OR USE CARD-EDGE CONNECTOR TO TERMINATE SHIELD GROUNDS TO BACK PLATE.
3. REFER TO SECTION 7 FOR RS-232 CHANNEL SETTINGS
- 4  REFER TO THE GTX 327 TRANSPONDER INSTALLATION MANUAL, 190-00187-02, FOR COMPLETE INFORMATION.
- 5  IF TWO OR MORE IFD SERIES UNITS ARE INSTALLED, THE RS-232 LINE ON P1001-41 AND P1001-42 MAY BE CROSS-CONNECTED TO CROSSFILL FLIGHT PLANS AND USER WAYPOINTS. TO CROSSFILL FLIGHT PLANS, IT IS REQUIRED THAT BOTH UNITS HAVE IDENTICAL DATABASE CYCLE DATES AND MAY BE REQUIRED THAT THEY HAVE IDENTICAL VERSIONS OF THE MAIN SOFTWARE. REFERENCE SECTION 4 FOR WIRING INFORMATION.
- 6  MAPMX (MAIN SOFTWARE VERSION 3.10 AND LATER) IS THE PREFERRED COMMUNICATION PROTOCOL FOR THE MX20/GMX200. OTHER INPUT PORTS ON MX20/GMX200 MAY BE USED INSTEAD OF THE PORT SHOWN. REFER TO APPROPRIATE MANUFACTURER'S INSTALLATION DOCUMENTATION.
7. REFER TO MANUFACTURER'S DOCUMENTATION FOR COMPLETE PINOUT AND INTERCONNECT INFORMATION. PINOUTS OF OTHER MANUFACTURER'S UNITS SHOWN HERE ARE FOR REFERENCE ONLY.
- 8  IF USING THE SERIAL PORT SOFTWARE METHOD TO CONFIGURE THE OUTPUT OF THE ENCODER, ENSURE THAT THE "TRIMBLE/GARMIN 9600 BPS" FORMAT IS SELECTED.
- 9  MOD LEVEL 8 (OR HIGHER) IS REQUIRED TO SUPPORT RS-232 INTERFACE. ENSURE THAT JUMPERS ARE SET FOR "TRIMBLE/GARMIN 9600 BPS" AND "10 FOOT RESOLUTION."
- 10  THE IFD STC DOES NOT PROVIDE INSTALLATION APPROVAL OF ANY PORTABLE ELECTRONIC DEVICES. ADDITIONAL INSTALLATION APPROVAL IS REQUIRED FOR THESE DEVICES.
- 11  IN SINGLE IFD INSTALLATIONS LEAVE P1001-41 AND P1001-42 OPEN THESE PINS MAY ONLY BE USED FOR CROSS SYNC OF TWO IFDS IN A DUAL IFD INSTALLATION.
12. IFD4XX SHOWN. IFD5XX AND ATLAS HAVE TWO ADDITIONAL RS-232 PORTS IN AND OUT ON CONNECTOR P1050 PINS 60, 61, 62, AND 63.

Figure D - 3: RS-232 Serial Data Interconnect



NOTES:

1. ALL WIRES TO BE 24 AWG OR GREATER UNLESS OTHERWISE NOTED.
2. AT IFD UNIT, TERMINATE SHIELD GROUNDS TO THE CONNECTOR BACKSHELL OR USE CARD EDGE CONNECTOR TO TERMINATE SHIELD GROUNDS TO THE BACKPLATE. THE SHIELD LEADS MUST BE LESS THAN 3.0 INCHES. CONNECT OTHER SHIELD GROUNDS TO AIRCRAFT CHASSIS WITH AS SHORT A CONDUCTOR AS POSSIBLE
3. IF THE GPS ARINC429 IN PORT 1 IS ALREADY USED FOR ANOTHER PURPOSE, THE GPS ARINC429 PORT 2 MAY BE CONNECTED INSTEAD
4. THE DEPICTED COLLINS EFIS-84 INTERFACE DOES NOT SUPPORT SELECTION OF THE GPS COURSE VIA THE EFIS CONTROL PANEL, A GAD42 IS REQUIRED FOR GPS SELECTED CRS
5. REFER TO MANUFACTURER'S DOCUMENTATION FOR COMPLETE PINOUT AND INTERCONNECT INFORMATION. PINOUTS OF OTHER MANUFACTURER'S UNITS SHOWN HERE ARE FOR REFERENCE ONLY
6. NOT APPLICABLE FOR IFD410/510/545, AND ATLAS FMS ONLY UNITS.

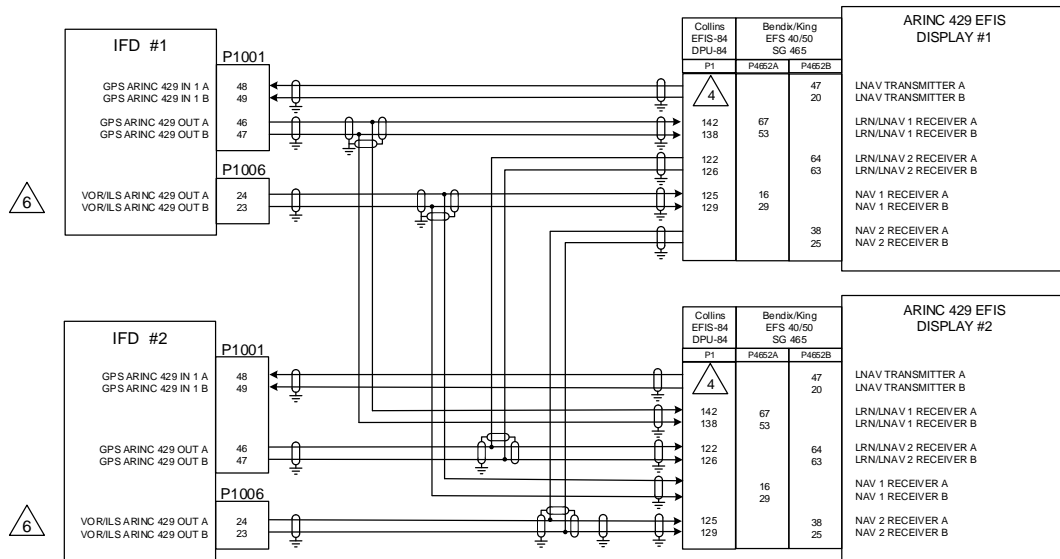
Figure D - 4: EFIS Interconnect

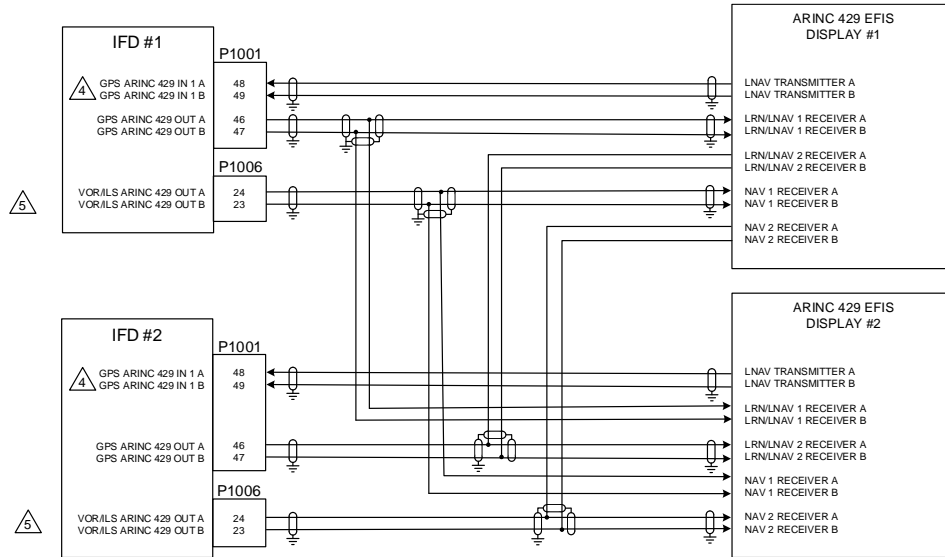

NOTES:

1. ALL WIRES TO BE 22 AWG OR GREATER UNLESS OTHERWISE NOTED.
 2. WIRE HARNESS OVERBRAID IS NOT SHOWN BUT MAY BE REQUIRED.
 3. REFER TO MANUFACTURER'S DOCUMENTATION FOR COMPLETE PINOUT AND INTERCONNECT INFORMATION.
- ⚠️ IF ARINC 429 PORT 1 IS NOT AVAILABLE, USE ANOTHER AVAILABLE PORT.
- ⚠️ NOT APPLICABLE FOR IFD410/510/545, or Atlas FMS Only units

Figure D - 5: Generic EFIS Interconnect

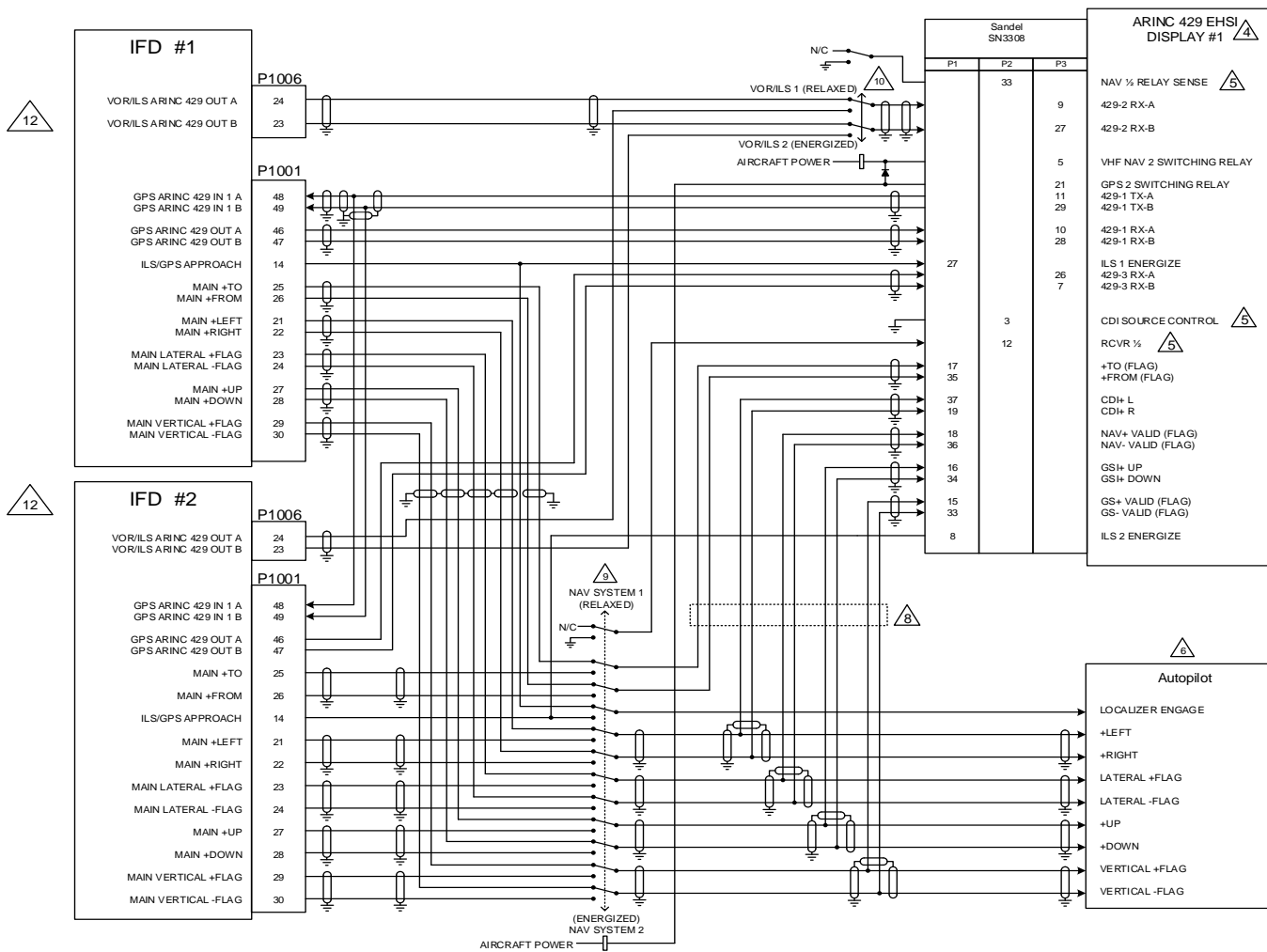

Figure D - 6: EHSI ARINC 429 Interconnect, Dual IFD5XX/4XX, Sandel SN3308 Interconnect

NOTES:

1. ALL WIRES TO BE 24 AWG OR GREATER UNLESS OTHERWISE NOTED.
2. AT IFD UNIT, TERMINATE SHIELD GROUNDS TO THE CONNECTOR BACKSHELL OR USE CARD-EDGE CONNECTOR TO TERMINATE SHIELD GROUNDS TO BACK PLATE.

3. IFD #1 SETUP

MAIN ARINC 429 CONFIG:	IN 1: LOW, SANDEL EHSI
	OUT: LOW, GAMA 429 GRPH W/INT
	SDI: LNAV 1
	VNAV: DISABLE LABELS WITH SANDEL SW VERSION PRIOR TO 2.3
	VNAV: ENABLE LABELS WITH SANDEL SW VERSION 2.3 OR GREATER
VOR/LOC/GS ARINC 429:	SDI: VOR/ILS 1
	SPEED: RX: LOW SPEED
	TX: LOW SPEED

IFD #2 SETUP

MAIN ARINC 429 CONFIG:	IN 1: LOW, SANDEL EHSI
	OUT: LOW, GAMA 429 GRPH W/INT
	SDI: LNAV 2
	VNAV: DISABLE LABELS WITH SANDEL SW VERSION PRIOR TO 2.3
	VNAV: ENABLE LABELS WITH SANDEL SW VERSION 2.3 OR GREATER
VOR/LOC/GS ARINC 429:	SDI: VOR/ILS 2
	SPEED: RX: LOW SPEED
	TX: LOW SPEED



SANDEL SN3308 #1 AND #2 SETUP ITEMS:

LNAV 1/2 SELECT: IFD540	NAV CHANGE:	NAV-1 ENABLE: YES
		PORT: 429 PORT-2*
		NAV-2 ENABLE: YES
		PORT: 429 PORT-2*
ANNUN: SERIAL	RELAY SENSE:	NAV-2: P2-33
COURSE: OBS/LEG		GPS-1: OFF
DEVIATION: ANALOG/IN		GPS-2: OFF
OBS ROT: NORMAL		CDI SRC SEL: P2-3
OBS CAL: 000.0		RCVR 1/2: P2-12

*WITH SANDEL SW VERSIONS PRIOR TO VERSION 2.3 NAV 1 /2 MUST BE SET TO "ANALOG" AND ILS MUST BE SET TO "VALID LOW" FOR PROPER OPERATION OF THE VDI. REFER TO SANDEL SIL 3308-8.



THESE PINS ON THE SANDEL SN3308 ARE CONFIGURABLE AND CAN BE CHANGED TO SUIT THE PARTICULAR INSTALLATION.



AUTOPILOT SHOWN FOR REFERENCE ONLY. REFER TO APPROPRIATE AUTOPILOT INTERCONNECT DIAGRAM.

7. IF IT IS DESIRED TO USE THE NAV RECEIVERS AS A SOURCE FOR THE SN3308 BEARING POINTERS, IT IS RECOMMENDED THAT THE IFD540/440 #1/#2 COMPOSITE OUTPUTS (P1006-8) BE CONNECTED TO THE SN3308 COMPOSITE INPUTS (P1-29 AND P1-10, #1 AND 2# RESPECTIVELY) AND THE SN3308 BRG NAV-1/NAV-2 BE SET TO "429+COMP".



WITH SANDEL SW VERSIONS PRIOR TO 2.3 ANALOG CONNECTIONS TO THE SN3308 ARE REQUIRED TO ALLOW VERTICAL GUIDANCE TO BE DISPLAYED FOR GPS APPROACHES.



USE RELAY AMERI-KING P/N AK-950-R12-()V OR EQUIVALENT.



USE RELAY LEACH P/N WN460-() () OR EQUIVALENT.

11. REFER TO MANUFACTURER'S DOCUMENTATION FOR COMPLETE PINOUT AND INTERCONNECT INFORMATION.



NOT APPLICABLE FOR IFD410/510/545 or ATLAS FMS ONLY UNITS

Figure D - 7: EHSI ARINC 429 Interconnect, Dual IFD5XX/4XX, Sandel SN3308 Interconnect

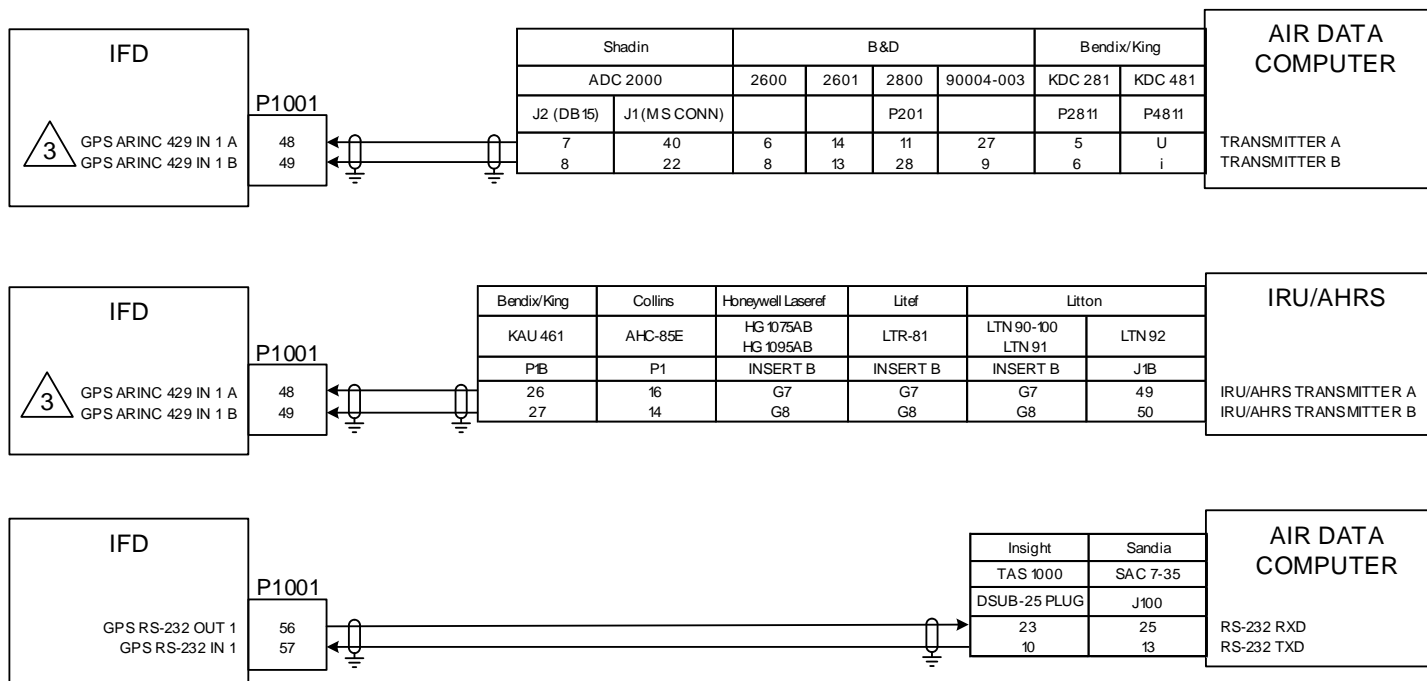

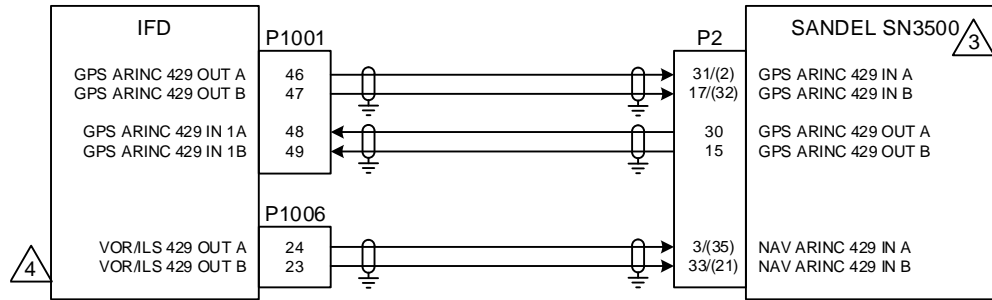

Figure D - 8: ARINC 429/RS-232 Air Data/IRU/AHRS Interconnect

NOTES:

1. ALL WIRES TO BE 22 AWG OR GREATER UNLESS OTHERWISE NOTED.
2. AT IFD UNIT, TERMINATE SHIELD GROUNDS TO THE CONNECTOR BACKSHELL OR USE CARD-EDGE CONNECTOR TO TERMINATE SHIELD GROUNDS TO BACK PLATE. THE SHIELD LEADS MUST BE LESS THAN 3.0 INCHES. CONNECT OTHER SHIELD GROUNDS TO AIRCRAFT CHASSIS WITH AS SHORT A CONDUCTOR AS PRACTICAL.
-  IF THE GPS ARINC 429 IN 1 PORT (P1001-48 AND -49) IS ALREADY USED FOR ANOTHER PURPOSE, THE GPS ARINC 429 IN 2 PORT (P1001-50 AND -51) MAY BE CONNECTED INSTEAD.
4. REFER TO SECTION 7 FOR ARINC 429 CHANNEL SETTINGS.
5. REFER TO SECTION 7 FOR RS-232 CHANNEL SETTINGS.
6. REFER TO MANUFACTURER'S DOCUMENTATION FOR COMPLETE PINOUT AND INTERCONNECT INFORMATION. PINOUTS OF OTHER UNITS SHOWN FOR REFERENCE ONLY.

Page 2 of 2



NOTES:

1. ALL WIRES TO BE 22 AWG OR GREATER UNLESS OTHERWISE NOTED.
2. AT IFD UNIT, TERMINATE SHIELD GROUNDS TO THE CONNECTOR BACKSHELL OR USE CARD-EDGE CONNECTOR TO TERMINATE SHIELD GROUNDS TO BACK PLATE – THE SHIELD LEADS MUST BE LESS THAN 3.0 INCHES. CONNECT OTHER SHIELD GROUNDS TO AIRCRAFT CHASSIS WITH AS SHORT A CONDUCTOR AS PRACTICAL.

 REFER TO MANUFACTURER'S DOCUMENTATION FOR COMPLETE PINOUT INFORMATION AND CONFIGURATION.

 NOT APPLICABLE FOR IFD410/510/545 OR ATLAS FMS ONLY UNITS

Figure D - 9: Sandel SN3500 Interconnect

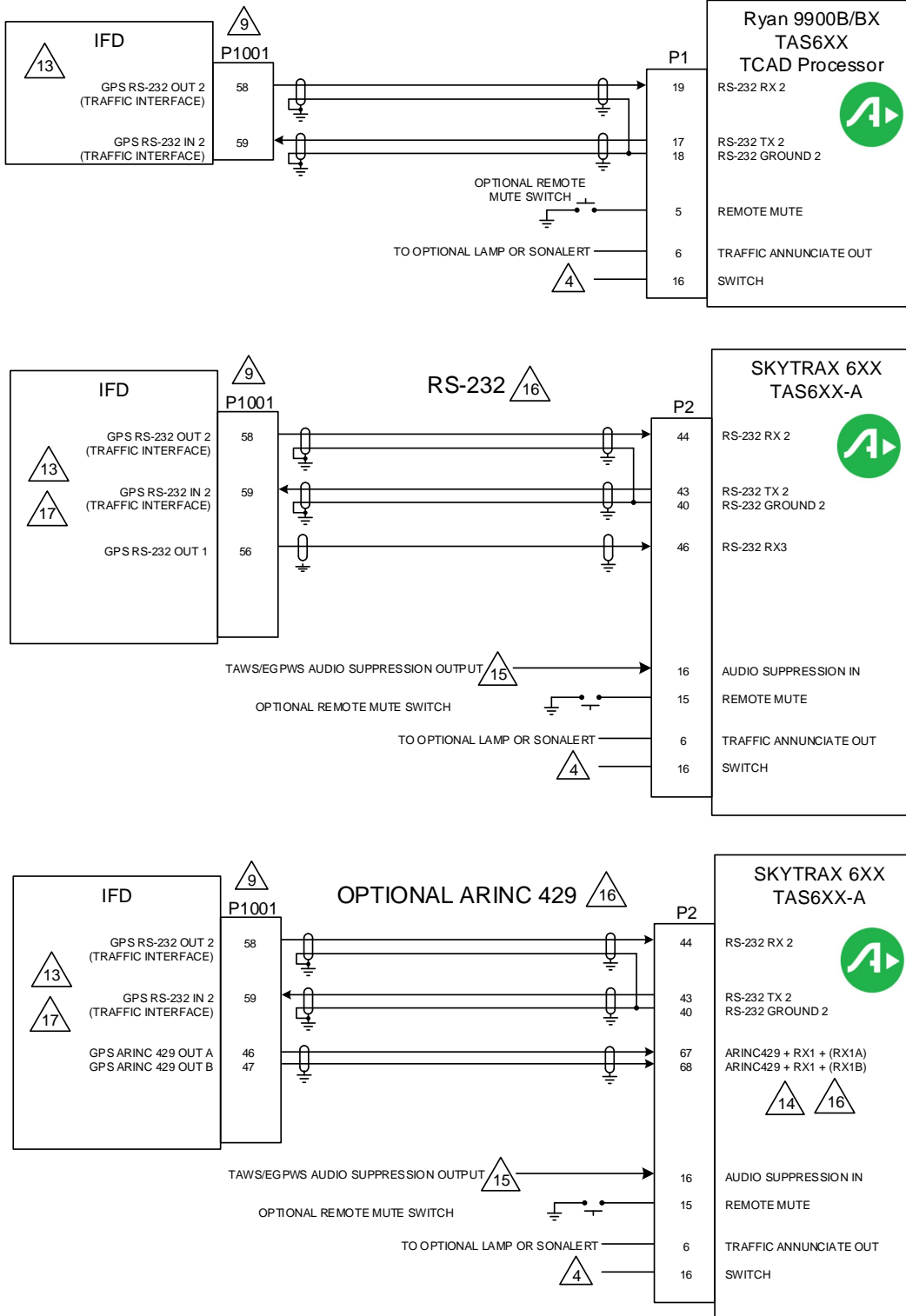

Figure D - 10: Traffic Advisory Interconnect

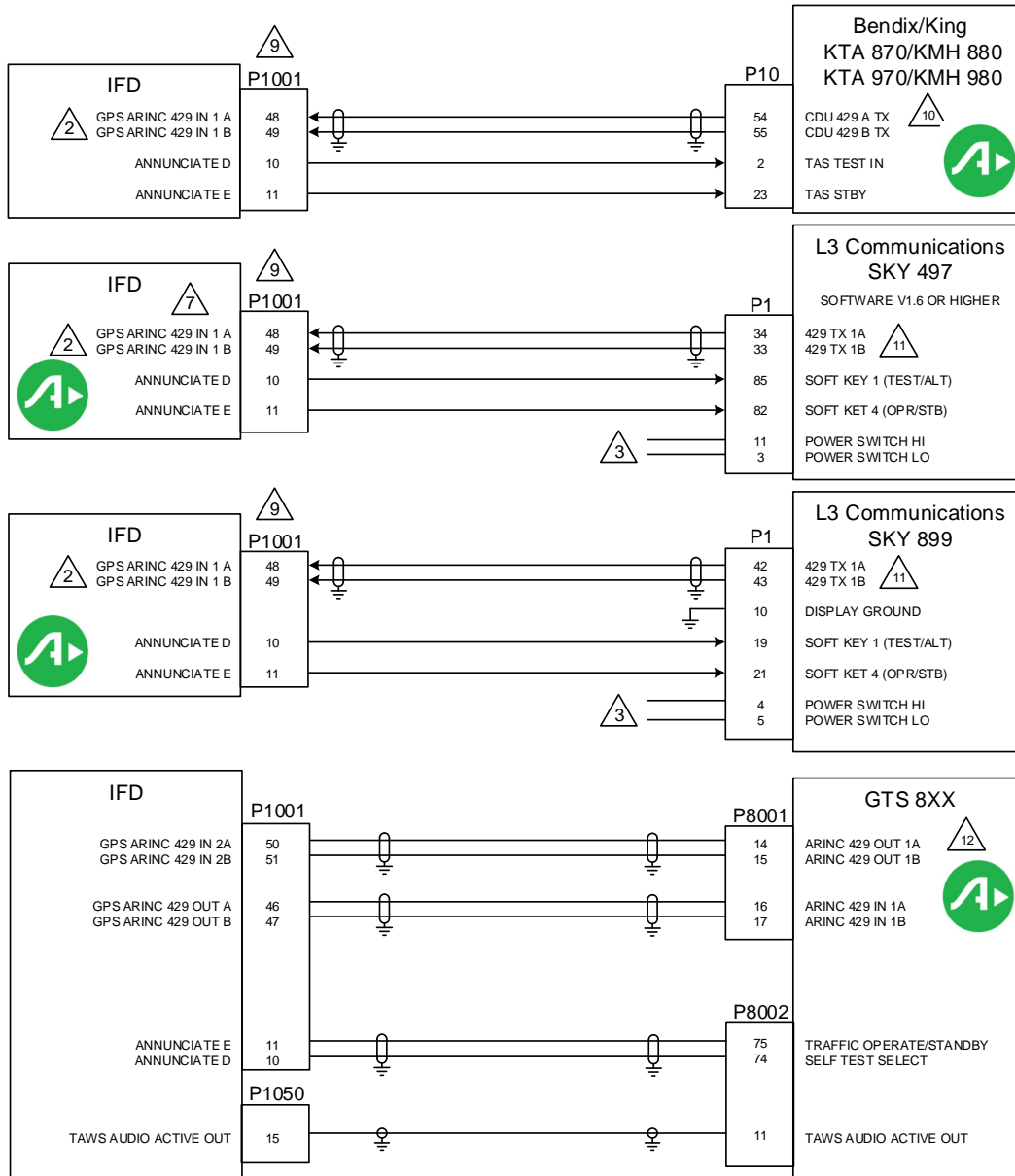
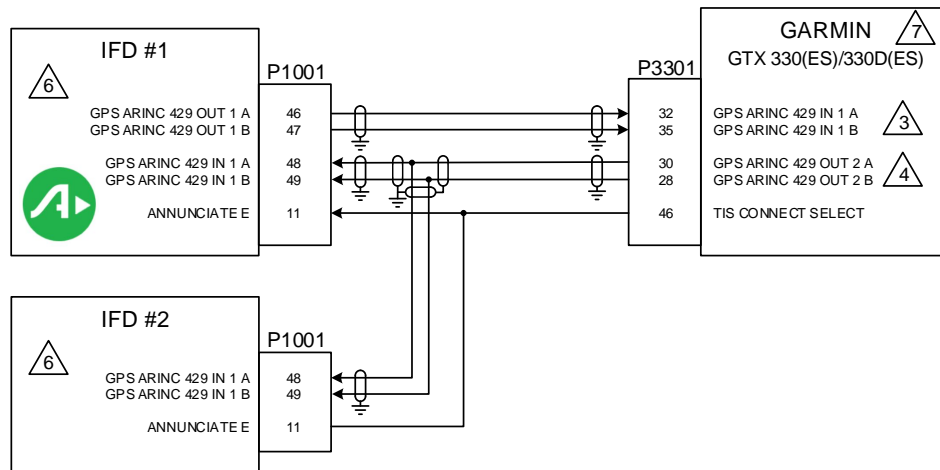

Figure D - 110: Traffic Advisory Interconnect

NOTES:

1. ALL WIRES TO BE 24 AWG OR GREATER UNLESS OTHERWISE NOTED.
2. IF THE GPS ARINC 429 IN 1 PORT (P1001-48 AND -49) IS ALREADY USED FOR ANOTHER PURPOSE, THE GPS ARINC 429 IN 2 PORT (P1001-50 AND -51) MAY BE CONNECTED INSTEAD.
3. THE SKYWATCH POWER SWITCH PINS, SHOWN ON P1, SHOULD BE CONNECTED TOGETHER TO TURN THE PROCESSOR UNIT ON AND DISCONNECTED TO TURN IT OFF. IF A SKYWATCH CONTROL/DISPLAY UNIT IS NOT IN THE INSTALLATION, A DEDICATED SWITCH MAY BE REQUIRED TO TURN THE SKYWATCH PROCESSOR UNIT ON OR OFF.
4. THE AVIDYNE/RYAN TAS PROCESSOR SWITCH PIN (P1-16 OR P2-54) SHOULD BE GROUNDED TO TURN THE PROCESSOR UNIT ON, AND OPEN TO TURN THIS UNIT OFF. IF A RYAN TCAD DISPLAY UNIT IS NOT IN THE INSTALLATION, A DEDICATED SWITCH MAY BE REQUIRED TO TURN THE TAS PROCESSOR UNIT ON AND OFF.
5. IF ANY OF THESE TRAFFIC SYSTEMS ARE INSTALLED WITHOUT A CONTROL/DISPLAY UNIT, A PLACARD IS REQUIRED NEAR THE IFD UNIT, INDICATING THAT A TRAFFIC ADVISORY SYSTEM IS INSTALLED, AND ITS DATA MAY BE DISPLAYED ON THE IFD5XX UNIT.
6. REFER TO MANUFACTURER'S DOCUMENTATION FOR COMPLETE PINOUT AND INTERCONNECT INFORMATION. PINOUTS OF OTHER INPUTS SHOWN FOR REFERENCE ONLY.
7. IN ORDER FOR SKYWATCH DATA TO BE DISPLAYED ON THE IFD5XX UNIT'S MAP PAGE, THE IFD5XX UNIT MUST HAVE A DIGITAL HEADING SOURCE, OR THE SKYWATCH MUST HAVE A SYNCHRO OR SERIAL HEADING SOURCE. A STEPPER HEADING SOURCE WILL NOT ALLOW SKYWATCH DATA TO BE DISPLAYED ON THE MAP PAGE.
8. AT IFD UNIT, TERMINATE SHIELD GROUNDS TO THE CONNECTOR BACKSHELL OR USE CARD-EDGE CONNECTOR SHIELD GROUNDS TO AIRCRAFT CHASSIS WITH AS SHORT A CONDUCTOR AS PRACTICAL.
9. REFER TO SECTION 7.0 FOR ARINC 429 AND FOR RS-232 SETTINGS. IF AN ARINC 429 TRAFFIC SOURCE IS USED, THE CORRESPONDING ARINC 429 INPUT MUST BE SET TO HIGH SPEED.
10. KTA 870/KMH 880/KTA 970/KMH 980 SYSTEMS MUST HAVE TRAFFIC CONFIGURED FOR "CONTROLLER TYPE: DISCRETE" AND "DISPLAY VALID: IGNORE".
11. SKYWATCH MUST BE CONFIGURED FOR AN ARINC 735 TYPE 1 DISPLAY.
12. FOR GTX 8XX CONFIGURATION SETTINGS, SEE THE GTX 8XX INSTALLATION MANUAL.
13. IN ORDER FOR AVIDYNE TAS TRAFFIC TO BE DISPLAYED ON THE IFD5XX, A HEADING SOURCE IS REQUIRED.
14. ACCEPTS ARINC 429 LABELS. INPUTS CAN BE HIGH OR LOW SPEED. NO CONFIGURATION IS REQUIRED.
15. IF AUDIO MUTING IS NECESSARY FOR LOWER-PRIORITY TRAFFIC ANNOUNCEMENTS, THEN USE THE AUDIO SUPPRESSION INPUT TO MUTE TAS. THE LINE IS PULLED LOW TO MUTE THE TAS. IF TAWS/EGPWS DRIVES OR PULLS THE AUDIO SUPPRESSION OUTPUT HIGH THEN THE OUTPUT MUST BE DIODE ISOLATED.
16. AVIDYNE TAS-A PROCESSORS ACCEPT GPS POSITION INPUTS ON RS232 OR ARINC 429 (BOTH DEPICTED), ONE INPUT REQUIRED.
17. CONFIGURE RS232 POSITION OUTPUT TO THE TAS-A, SET OUTPUT TO ADS-B+ (G).
CONFIGURE ARINC 429 POSITION OUTPUT TO THE TAS-A, SET OUTPUT TO ARINC 743A

Figure D - 10: Traffic Advisory Interconnect



NOTES:

1. ALL WIRES TO BE 22 AWG OR GREATER UNLESS OTHERWISE NOTED.
 2. AT IFD UNIT, TERMINATE SHIELD GROUNDS TO THE CONNECTOR BACKSHELL OR USE CARD-EDGE CONNECTOR TO TERMINATE SHIELD GROUNDS TO BACK PLATE. THE SHIELD LEADS MUST BE LESS THAN 3.0 INCHES. CONNECT OTHER SHIELD GROUNDS TO AIRCRAFT CHASSIS WITH AS SHORT A CONDUCTOR AS PRACTICAL.
3. ARINC 429 IN 1 (P3301-32 AND -35) INPUT ALLOWS AUTOMATED START AND STOP OF FLIGHT TIMER AND PLACES THE TRANSPONDER IN GROUND (GND) MODE UPON LANDING.
4. IF EXTERNAL STBY SELECT IS CONNECTED IN THIS INSTALLATION USE GTX 330 ARINC 429 OUT 1 A AND 1 B, (PINS 37 AND 34) RATHER THAN ARINC 429 OUT 2 A AND 2 B (PINS 30 AND 28) SHOWN. ALTITUDE DATA WILL NOT BE TRANSMITTED OVER ARINC 429 PORT 2 TO THE IFD5XX/4XX/ATLAS UNIT WHEN EXTERNAL STBY SELECT IS GROUNDED.
5. WHEN TIS IS USED IN THE AIRCRAFT DO NOT CONNECT ANOTHER TRAFFIC SYSTEM TO THE SAME IFD UNIT.
6. IFD SETUP:
- MAIN ARINC 429 CONFIG: IN 1: HIGH, GARMIN GTX 330
OUT: SET TO MATCH INSTALLATION
7. GTX 330 SETUP:
- 429 INPUT CHANNEL 1: GPS (SPEED SET TO MATCH IFD #1 OUTPUT)
429 OUTPUT CHANNEL 2: GARMIN W/TIS

Figure D - 12: GTX 330 Interconnect

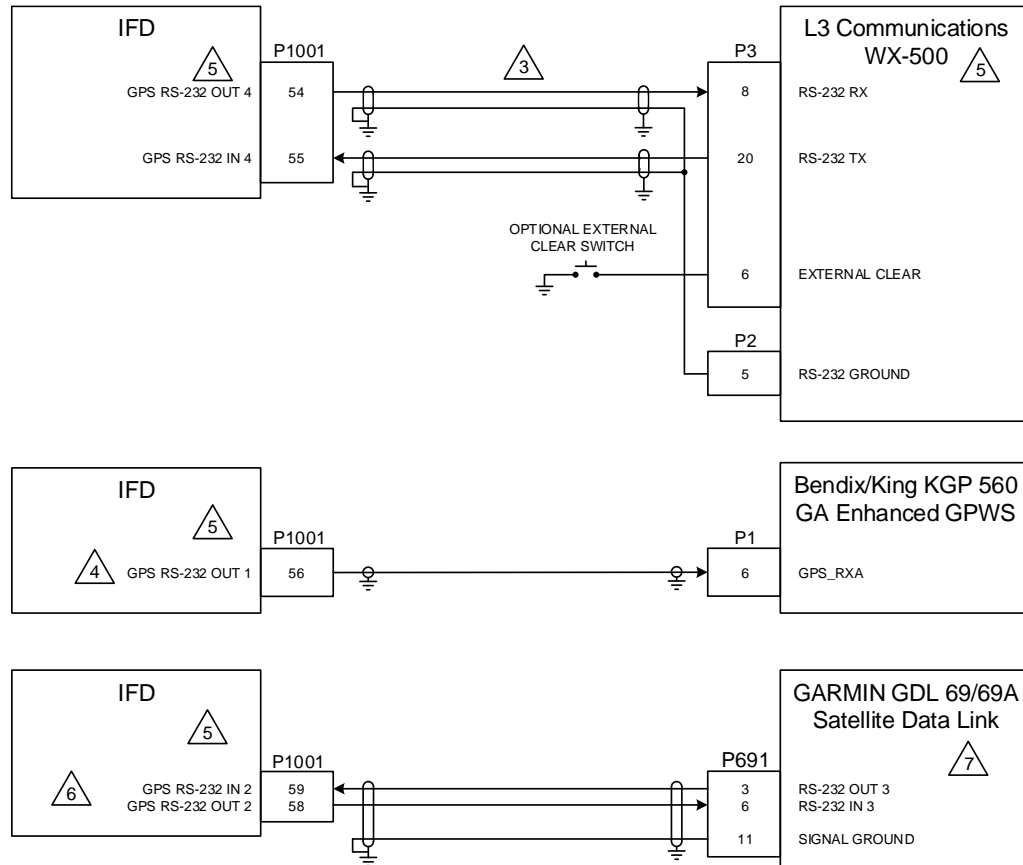

NOTES:

1. ALL WIRES TO BE 22 AWG OR GREATER UNLESS OTHERWISE NOTED.
 2. AT IFD UNIT, TERMINATE SHIELD GROUNDS TO THE CONNECTOR BACKSHELL OR USE CARD-EDGE CONNECTOR TO TERMINATE SHIELD GROUNDS TO BACK PLATE. THE SHIELD LEADS MUST BE LESS THAN 3.0 INCHES. CONNECT OTHER SHIELD GROUNDS TO AIRCRAFT CHASSIS WITH AS SHORT A CONDUCTOR AS PRACTICAL.
3. IN ORDER FOR WX-500 DATA TO BE DISPLAYED ON THE IFD540 UNIT'S MAP PAGE, THE IFD540/440 MUST HAVE A DIGITAL HEADING SOURCE, OR THE WX-500 MUST HAVE A SYNCHRO OR SERIAL HEADING SOURCE. A STEPPER HEADING SOURCE WILL NOT ALLOW WX-500 DATA TO BE DISPLAYED ON THE MAP PAGE.
4. IF AN RS-232 OUTPUT PORT IS CONFIGURED FOR THE HONEYWELL EGPWS, THE CORRESPONDING RS-232 INPUT OF THE SAME PORT MAY NOT BE USED.
5. REFER TO SECTION 7.0 FOR RS-232 CHANNEL SETTINGS.
6. CONNECTION TO RS-232 PORT #2 OF THE IFD5XX/4XX/ATLAS UNIT IS SHOWN. IF PORT #2 IS ALREADY IN USE, ANY OTHER AVAILABLE RS-232 PORT MAY BE USED AS WELL EXCEPT PORT #3.
7. CONNECTION TO RS-232 PORT #2 OF THE GDL 69/69A MAY BE USED AS WELL.
8. REFER TO MANUFACTURER'S DOCUMENTATION FOR COMPLETE PINOUT AND INTERCONNECT INFORMATION. PINOUT OF OTHER UNITS SHOWN FOR REFERENCE ONLY.

Figure D - 13: Terrain and Weather Interconnect

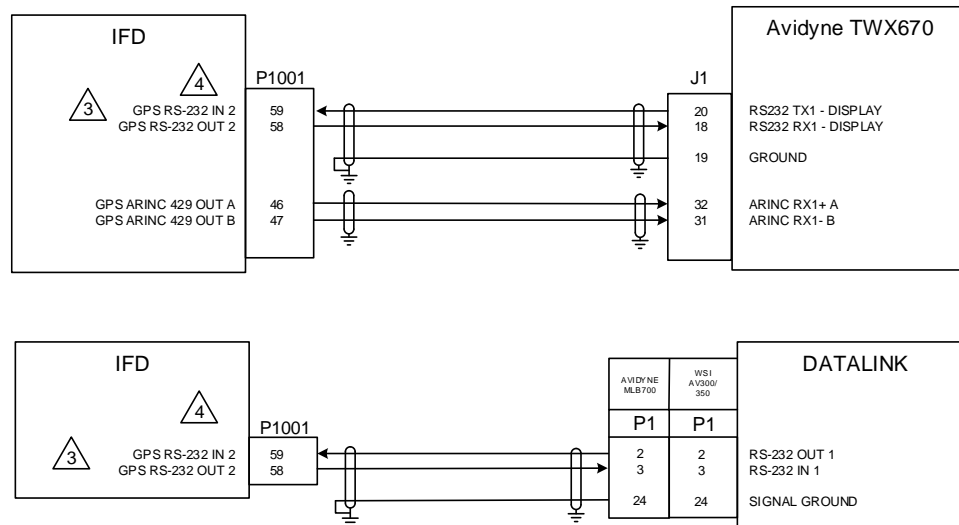

NOTES:

1. ALL WIRES TO BE 22 AWG OR GREATER UNLESS OTHERWISE NOTED.
 2. AT IFD UNIT, TERMINATE SHIELD GROUNDS TO THE CONNECTOR BACKSHELL OR USE CARD-EDGE CONNECTOR TO TERMINATE SHIELD GROUNDS TO BACK PLATE. THE SHIELD LEADS MUST BE LESS THAN 3.0 INCHES. CONNECT OTHER SHIELD GROUNDS TO AIRCRAFT CHASSIS WITH AS SHORT A CONDUCTOR AS PRACTICAL.
- 3 CONNECTION TO RS-232 PORT #2 OF THE IFD540/440 UNIT IS SHOWN. IF PORT #2 IS ALREADY IN USE, ANY OTHER AVAILABLE RS-232 PORT MAY BE USED AS WELL.
- 4 REFER TO SECTION 7.0 FOR RS-232 CHANNEL SETTINGS.
5. DATA SERVICE FOR MLB700, WSI AV300/350 HAS BEEN DISCONTINUED

Figure D - 14: Weather Interconnect

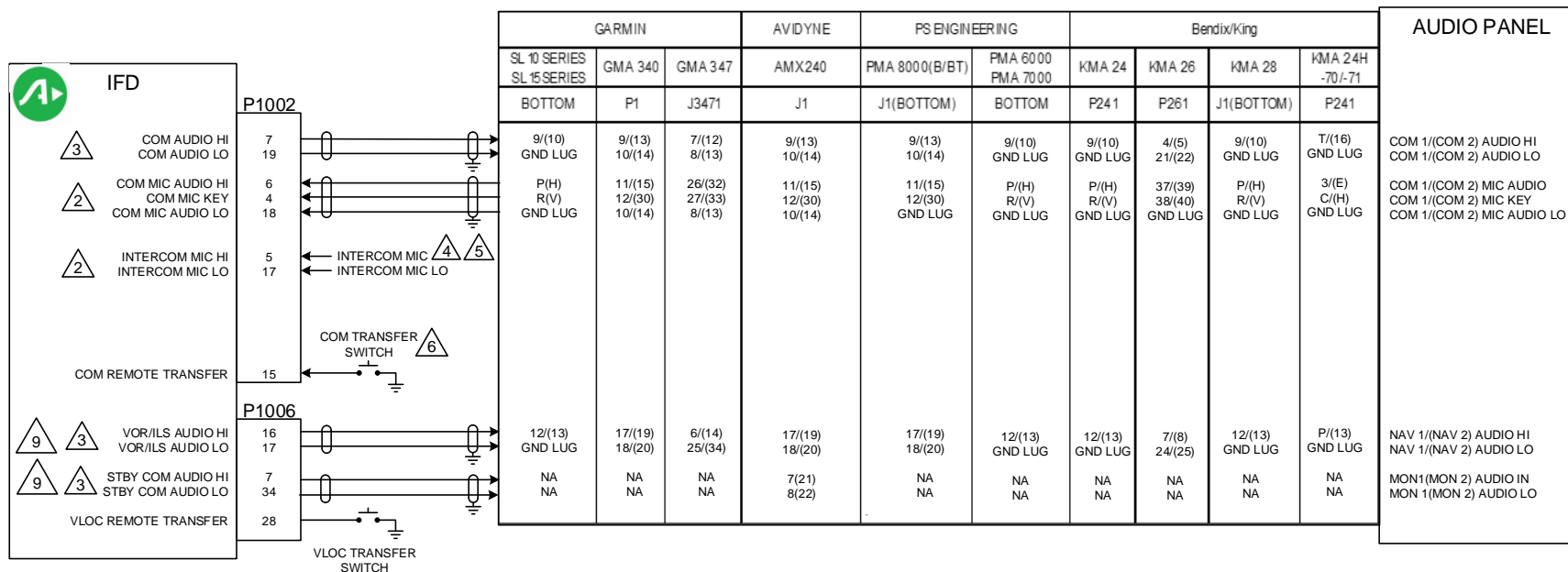
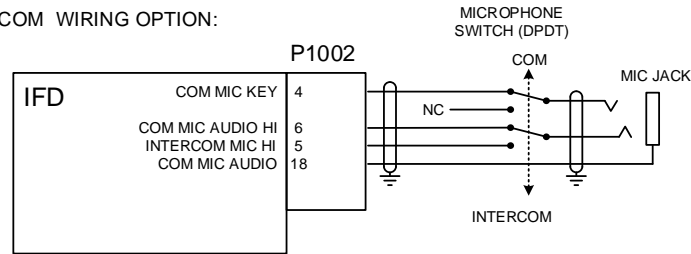

Figure D - 15: Audio Panel Interconnect

NOTES:

1. ALL WIRES TO BE 22 AWG OR GREATER UNLESS OTHERWISE NOTED.
2. CONNECTING TWO MICROPHONES TO MIC AUDIO HI/LO OR INTERCOM MIC HI/LO AT THE SAME TIME MAY RESULT IN WEAK OR DISTORTED AUDIO. MIC ISOLATION RELAYS ARE RECOMMENDED SO THAT ONLY ONE MIC IS ACTIVE AT A TIME.
3. IF THE AUDIO PANEL DOES NOT HAVE A LO INPUT. IT SHOULD BE CONNECTED TO A GROUND LUG AT THE AUDIO PANEL.
4. THE IFD INTERCOM FUNCTION SHOULD ONLY BE USED IF THERE IS NO OTHER INTERCOM SYSTEM IN THE AIRCRAFT.
5. INTERCOM WIRING OPTION:



6. THE COM REMOTE TRANSFER INPUT (P1002-15) MAY BE USED FOR EMERGENCY OPERATION OF THE COM TRANSMITTER. IF THE REMOTE TRANSFER SWITCH IS ACTIVE FOR THREE SECONDS, THE ACTIVE COM FREQUENCY WILL CHANGE TO 121.50 MHZ.
7. REFER TO MANUFACTURER'S DOCUMENTATION FOR COMPLETE PINOUT AND INTERCONNECT INFORMATION. PINOUT OF OTHER UNITS SHOWN FOR REFERENCE ONLY.
8. SHIELDS FOR AUDIO CABLES SHOULD BE GROUNDED AT ONE END (WITH LEADS LESS THAN 3.0 INCHES) AND LEFT FLOATING AT THE OTHER END. IF SHIELDED AUDIO CABLE IS CARRIED THROUGH DISCONNECT, CARRY SHIELD GROUND THROUGH DISCONNECT ON SEPARATE PIN.
9. NOT APPLICABLE FOR IFD 700-00179-X1X, 700-00182-X1X,-X3X

Figure D -15: Audio Panel Interconnect

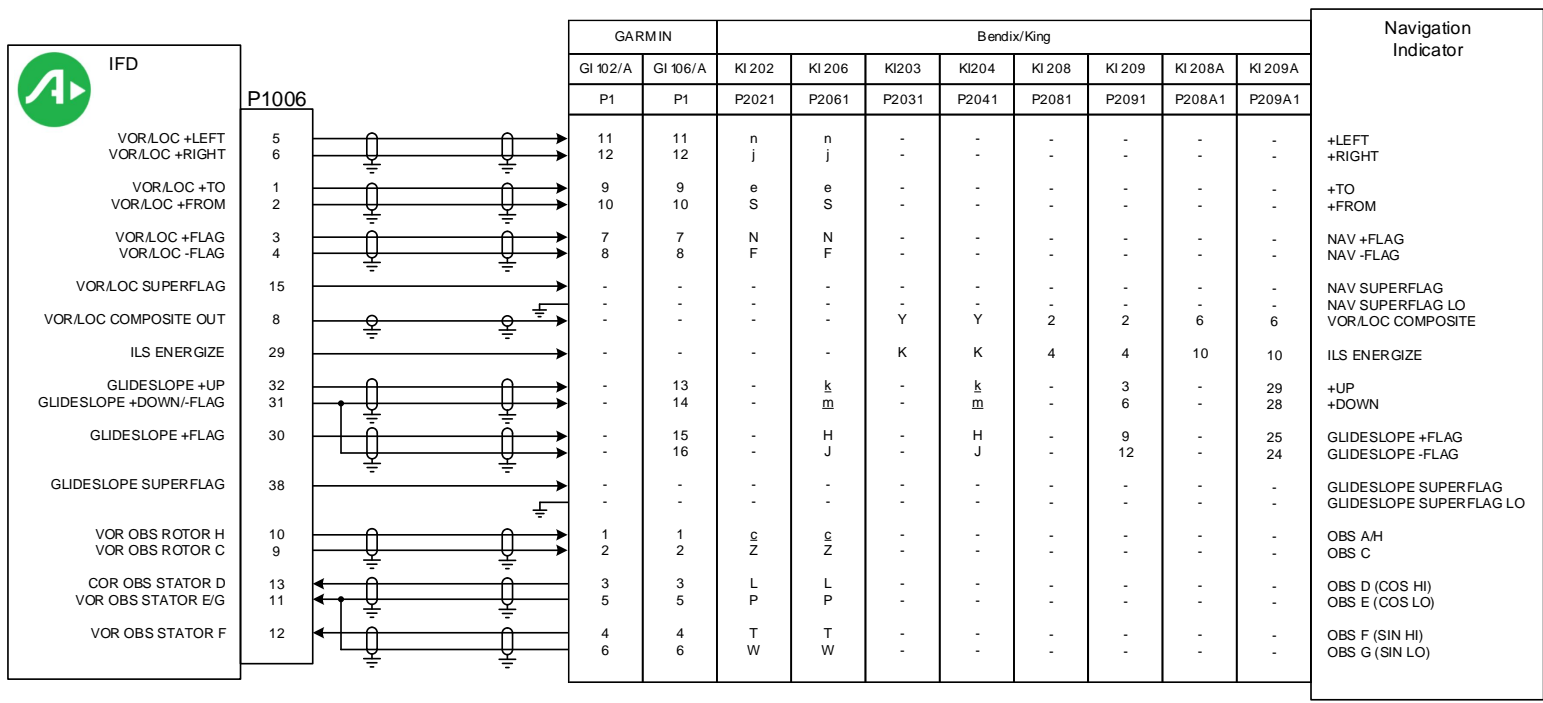

NOTES:

1. ALL WIRES TO BE 22 AWG OR GREATER UNLESS OTHERWISE NOTED.
2. THIS INTERCONNECT APPLIES ONLY WHEN IT IS DESIRED FOR A SEPARATE INDICATOR TO DISPLAY IFD5XX/4XX/ATLAS VOR/ILS INFORMATION (REGARDLESS OF THE SELECTED NAVIGATION SOURCE).
3. REFER TO MANUFACTURER'S DOCUMENTATION FOR COMPLETE PINOUT AND INTERCONNECT INFORMATION. PINOUTS OF OTHER UNITS SHOWN FOR REFERENCE ONLY.
4. AT IFD UNIT, TERMINATE SHIELD GROUNDS TO THE CONNECTOR BACKSHELL OR USE CARD-EDGE CONNECTOR TO TERMINATE SHIELD GROUNDS TO BACK PLATE – THE SHIELD LEADS MUST BE LESS THAN 3.0 INCHES. CONNECT OTHER SHIELD GROUNDS TO AIRCRAFT CHASSIS WITH AS SHORT A CONDUCTOR AS PRACTICAL.
5. NOT APPLICABLE FOR IFD410/510/545 OR ATLAS FMS ONLY UNITS

Figure D - 16: VOR/ILS Indicator Interconnect

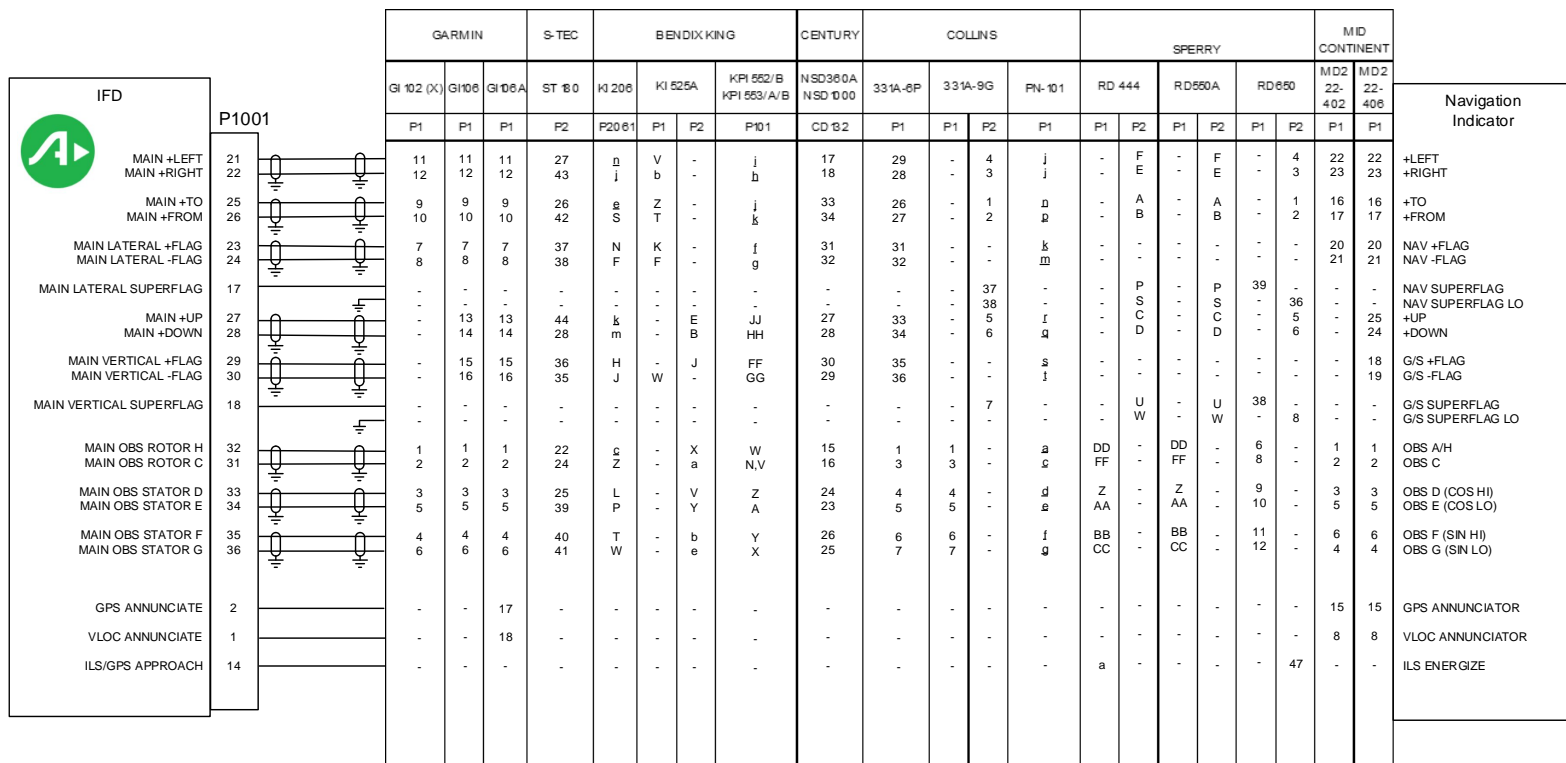

NOTES:

1. ALL WIRES TO BE 22 AWG OR GREATER UNLESS OTHERWISE NOTED.
2. REFER TO MANUFACTURER'S DOCUMENTATION FOR COMPLETE PINOUT AND INTERCONNECT INFORMATION. PINOUTS OF OTHER UNITS SHOWN FOR REFERENCE ONLY.
3. AT IFD UNIT, TERMINATE SHIELD GROUNDS TO THE CONNECTOR BACKSHELL OR USE CARD-EDGE CONNECTOR TO TERMINATE SHIELD GROUNDS TO BACK PLATE – THE SHIELD LEADS MUST BE LESS THAN 3.0 INCHES. CONNECT OTHER SHIELD GROUNDS TO AIRCRAFT CHASSIS WITH AS SHORT A CONDUCTOR AS PRACTICAL.
4. LOWER CASE PIN DESIGNATORS ARE SHOWN AS UNDERLINED LETTERS.

Figure D - 17: Main Indicator Interconnect

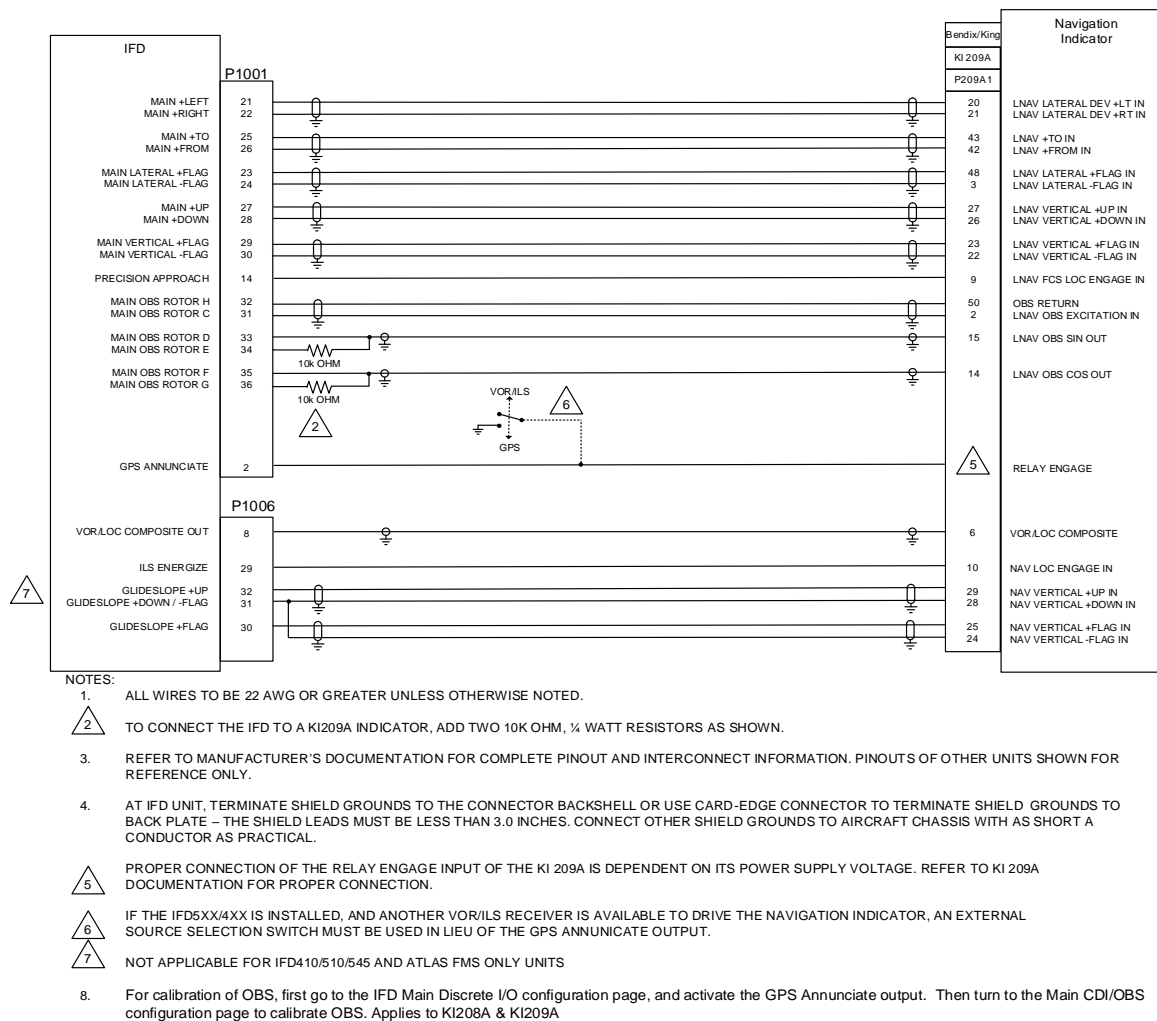
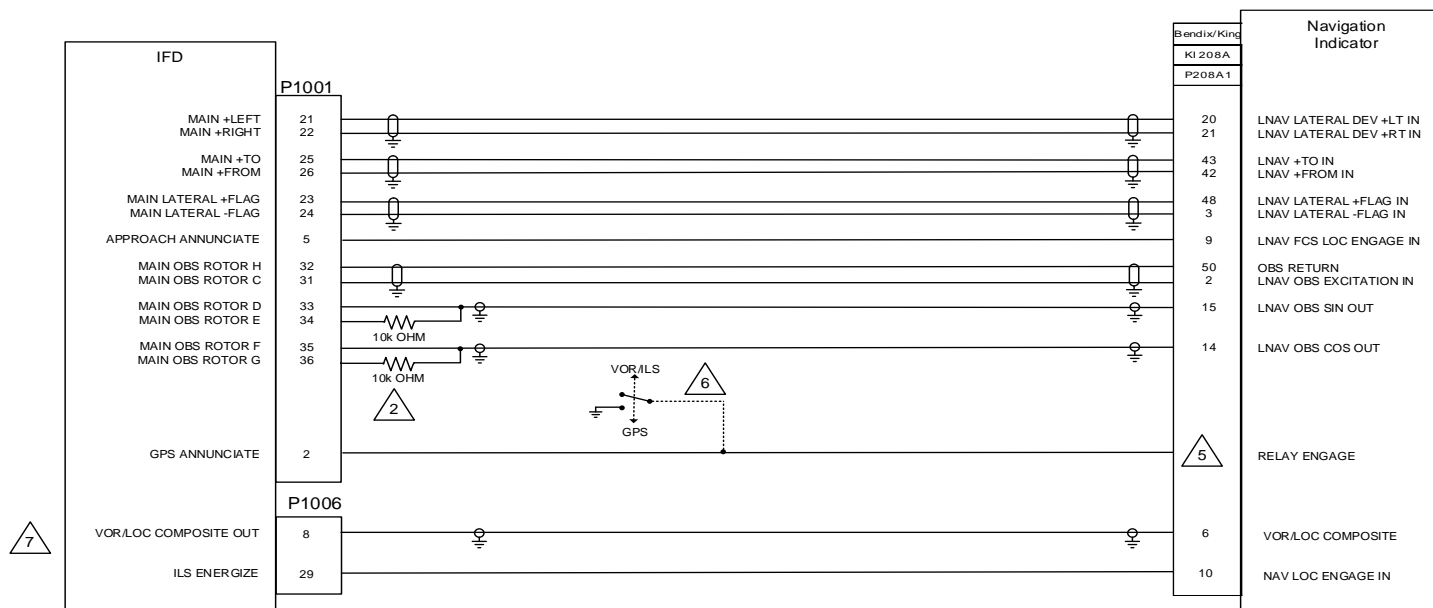

Figure D - 18 Main Indicator KI209



NOTES:

1. ALL WIRES TO BE 22 AWG OR GREATER UNLESS OTHERWISE NOTED.
2. TO CONNECT THE IFD TO A KI208A INDICATOR, ADD TWO 10K OHM, ¼ WATT RESISTORS AS SHOWN.
3. REFER TO MANUFACTURER'S DOCUMENTATION FOR COMPLETE PINOUT AND INTERCONNECT INFORMATION. PINOUTS OF OTHER UNITS SHOWN FOR REFERENCE ONLY.
4. AT IFD UNIT, TERMINATE SHIELD GROUNDS TO THE CONNECTOR BACKSHELL OR USE CARD-EDGE CONNECTOR TO TERMINATE SHIELD GROUNDS TO BACK PLATE – THE SHIELD LEADS MUST BE LESS THAN 3.0 INCHES. CONNECT OTHER SHIELD GROUNDS TO AIRCRAFT CHASSIS WITH AS SHORT A CONDUCTOR AS PRACTICAL.
5. PROPER CONNECTION OF THE RELAY ENGAGE INPUT OF THE KI 208A IS DEPENDENT ON ITS POWER SUPPLY VOLTAGE. REFER TO KI 208A DOCUMENTATION FOR PROPER CONNECTION.
6. IF THE IFD IS INSTALLED, AND ANOTHER VOR/ILS RECEIVER IS AVAILABLE TO DRIVE THE NAVIGATION INDICATOR, AN EXTERNAL SOURCE SELECTION SWITCH MUST BE USED IN LIEU OF THE GPS ANNUNCIATE OUTPUT.
7. NOT APPLICABLE FOR IFD410/510/545 AND ATLAS FMS ONLY UNITS

Figure D - 19: Main Indicator KI208A Interconnect

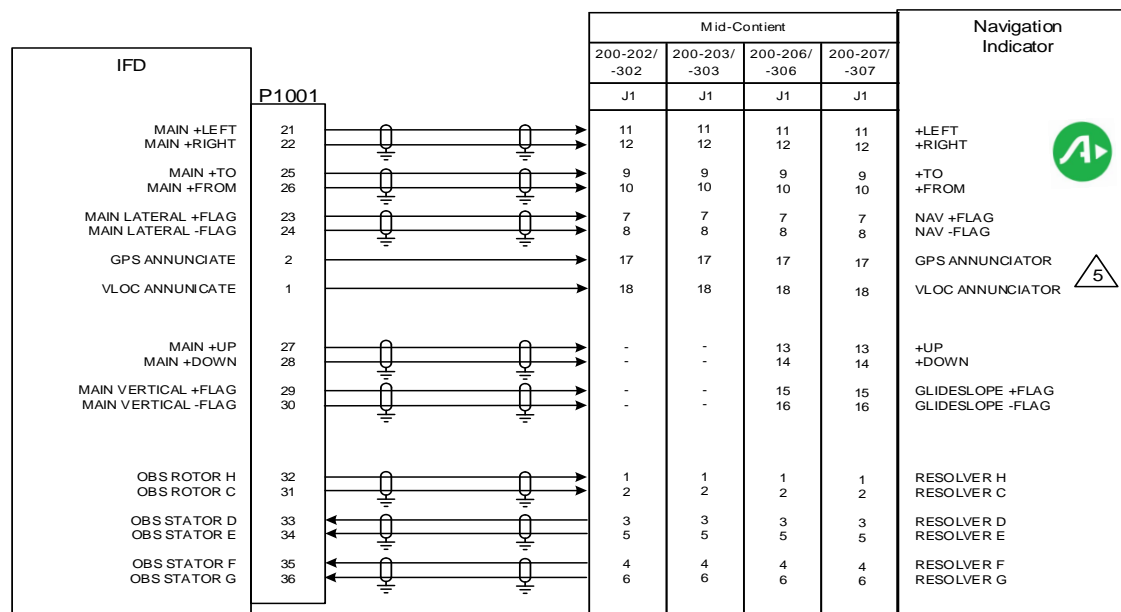

NOTES:

1. ALL WIRES TO BE 22 AWG OR GREATER UNLESS OTHERWISE NOTED.
2. THE 200-202/-203/-302/-303 DOES NOT HAVE VERTICAL DEVIATION INDICATOR. DO NOT USE FOR IFR NAVIGATION.
3. REFER TO MANUFACTURER'S DOCUMENTATION FOR COMPLETE PINOUT AND INTERCONNECT INFORMATION. PINOUTS OF OTHER UNITS SHOWN FOR REFERENCE ONLY.
4. AT IFD UNIT, TERMINATE SHIELD GROUNDS TO THE CONNECTOR BACKSHELL OR USE CARD-EDGE CONNECTOR TO TERMINATE SHIELD GROUNDS TO BACK PLATE – THE SHIELD LEADS MUST BE LESS THAN 3.0 INCHES. CONNECT OTHER SHIELD GROUNDS TO AIRCRAFT CHASSIS WITH AS SHORT A CONDUCTOR AS PRACTICAL.



NAVIGATION ANNUNCIATION

Figure D - 20: Main Indicator MD200-20X/-30X Interconnect

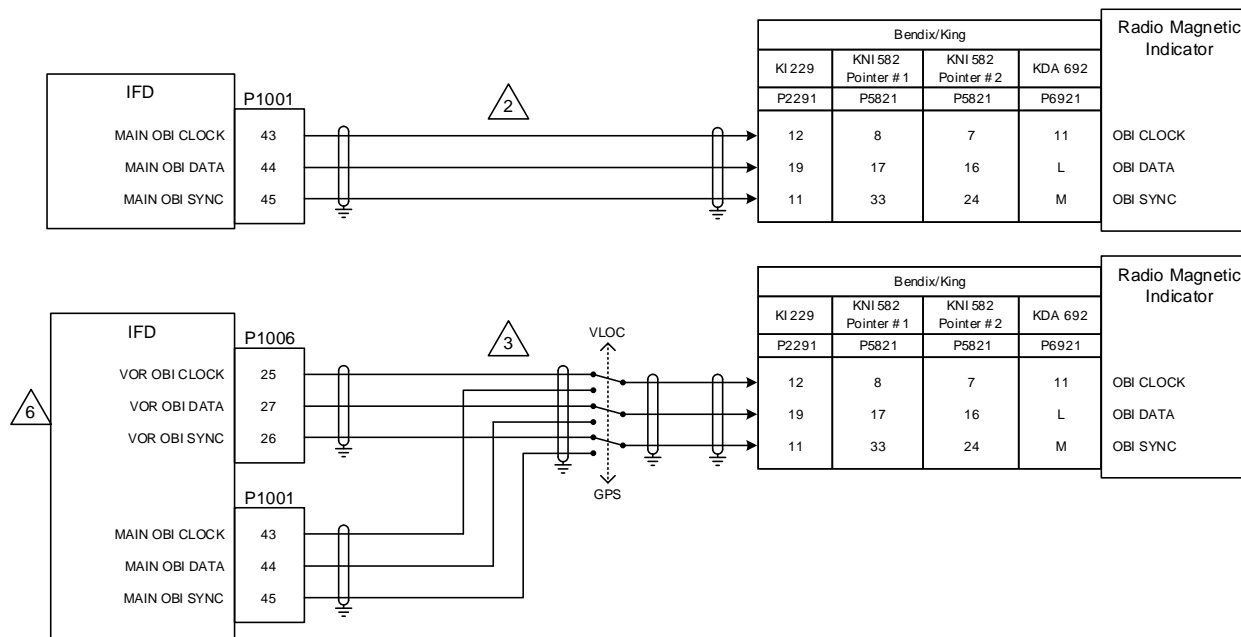

NOTES:

1. ALL WIRES TO BE 22 AWG OR GREATER UNLESS OTHERWISE NOTED.
2. IF IT IS DESIRED FOR THE RMI POINTER TO SWITCH WITH THE CDI BUTTON ON THE FRONT PANEL OF THE IFD540/440. INSTALL AS PER THE TOP DIAGRAM. AND SELECT TRACK CDI FOR THE OBI SOURCE FIELD OF THE MAIN CDI/OBS CONFIG PAGE.
3. IF IT IS DESIRED TO USE A SEPARATE SWITCH FOR THE RMI POINTER, INSTALL AS PER BOTTOM DIAGRAM AND SELECT ALWAYS GPS FOR THE OBI SOURCE FIELD OF THE MAIN CDI/OBS CONFIG PAGE.
4. AT IFD UNIT, TERMINATE SHIELD GROUNDS TO THE CONNECTOR BACKSHELL OR USE CARD-EDGE CONNECTOR TO TERMINATE SHIELD GROUNDS TO BACK PLATE – THE SHIELD LEADS MUST BE LESS THAN 3.0 INCHES. CONNECT OTHER SHIELD GROUNDS TO AIRCRAFT CHASSIS WITH AS SHORT A CONDUCTOR AS PRACTICAL.
5. REFER TO MANUFACTURER'S DOCUMENTATION FOR COMPLETE PINOUT AND INTERCONNECT INFORMATION. PINOUTS OF OTHER UNITS SHOWN FOR REFERENCE ONLY.
6. NOT APPLICABLE FOR IFD410/510/545 OR ATLAS FMS ONLY UNITS

Figure D - 21: RMI/OBI Interconnect

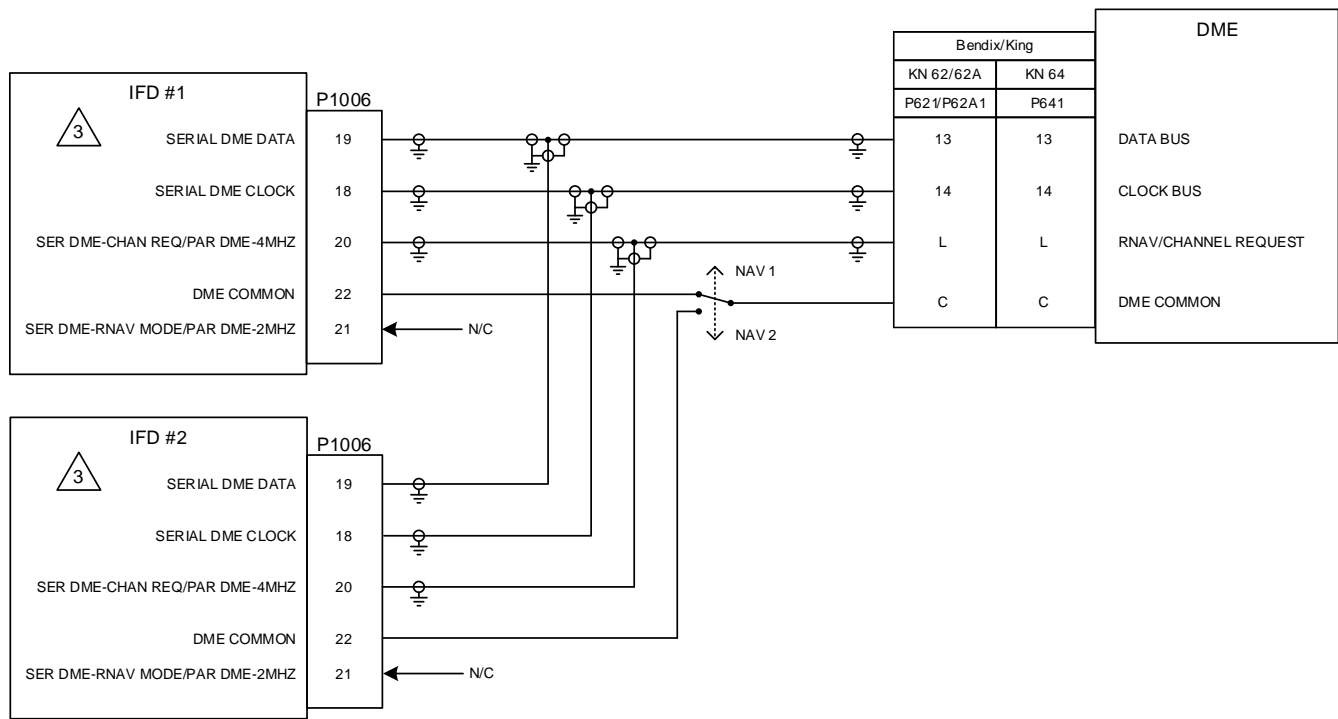

NOTES:

1. ALL WIRES TO BE 22 AWG OR GREATER UNLESS OTHERWISE NOTED.
 2. AT IFD UNIT, TERMINATE SHIELD GROUNDS TO THE CONNECTOR BACKSHELL OR USE CARD-EDGE CONNECTOR TO TERMINATE SHIELD GROUNDS TO BACK PLATE – THE SHIELD LEADS MUST BE LESS THAN 3.0 INCHES. CONNECT OTHER SHIELD GROUNDS TO AIRCRAFT CHASSIS WITH AS SHORT A CONDUCTOR AS PRACTICAL.
- 3** THE IFD MUST BE CONFIGURED AT INSTALLATION TO OUTPUT KING SERIAL DME TUNING DATA UNDER THE DME CHANNEL MODE.
4. REFER TO MANUFACTURER'S DOCUMENTATION FOR COMPLETE PINOUT AND INTERCONNECT INFORMATION. PINOUTS OF OTHER UNITS SHOWN FOR REFERENCE ONLY.
 5. NOT APPLICABLE FOR IFD410/510/545 OR ATLAS FMS ONLY UNITS

Figure D - 22: King Serial DME Tuning Interconnect, Panel Mount

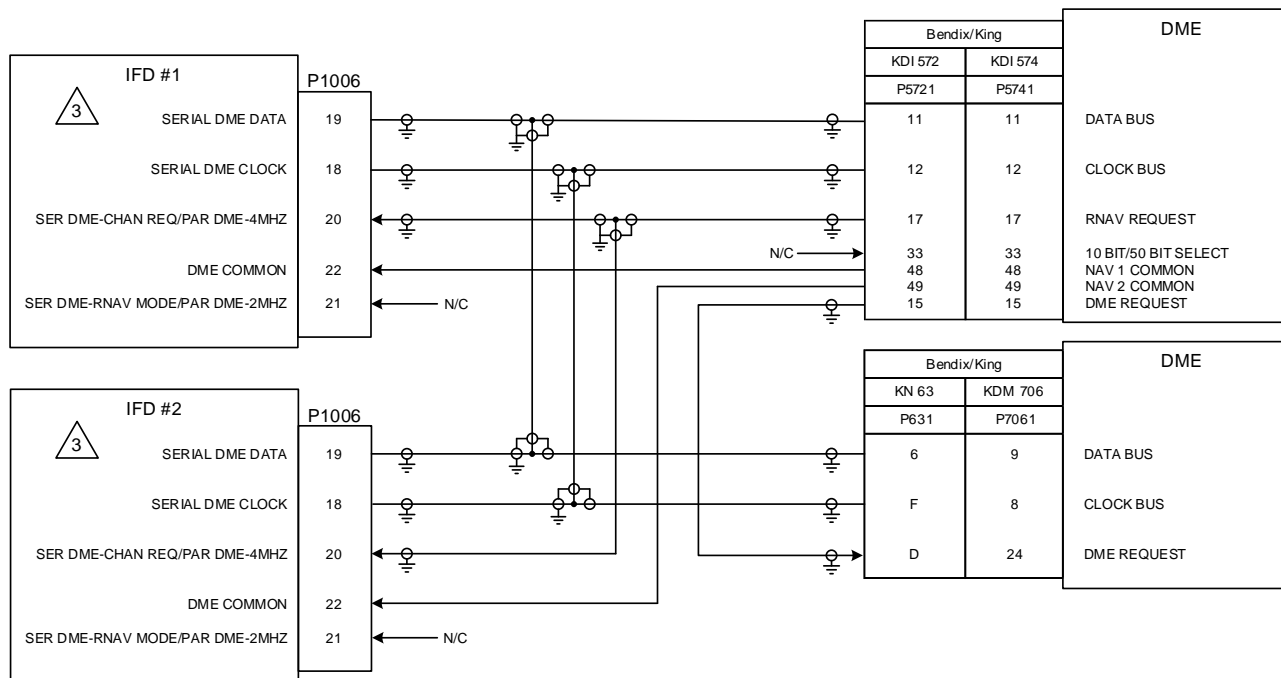

NOTES:

1. ALL WIRES TO BE 22 AWG OR GREATER UNLESS OTHERWISE NOTED.
 2. AT IFD UNIT, TERMINATE SHIELD GROUNDS TO THE CONNECTOR BACKSHELL OR USE CARD-EDGE CONNECTOR TO TERMINATE SHIELD GROUNDS TO BACK PLATE – THE SHIELD LEADS MUST BE LESS THAN 3.0 INCHES. CONNECT OTHER SHIELD GROUNDS TO AIRCRAFT CHASSIS WITH AS SHORT A CONDUCTOR AS PRACTICAL.
- 3** THE IFD MUST BE CONFIGURED AT INSTALLATION TO OUTPUT KING SERIAL DME TUNING DATA UNDER THE DME CHANNEL MODE.
4. REFER TO MANUFACTURER'S DOCUMENTATION FOR COMPLETE PINOUT AND INTERCONNECT INFORMATION. PINOUTS OF OTHER UNITS SHOWN FOR REFERENCE ONLY.
 5. NOT APPLICABLE FOR IFD410/510/545 OR ATLAS FMS ONLY UNITS

Figure D - 23: King Serial DME Tuning Interconnect, Remote Mount

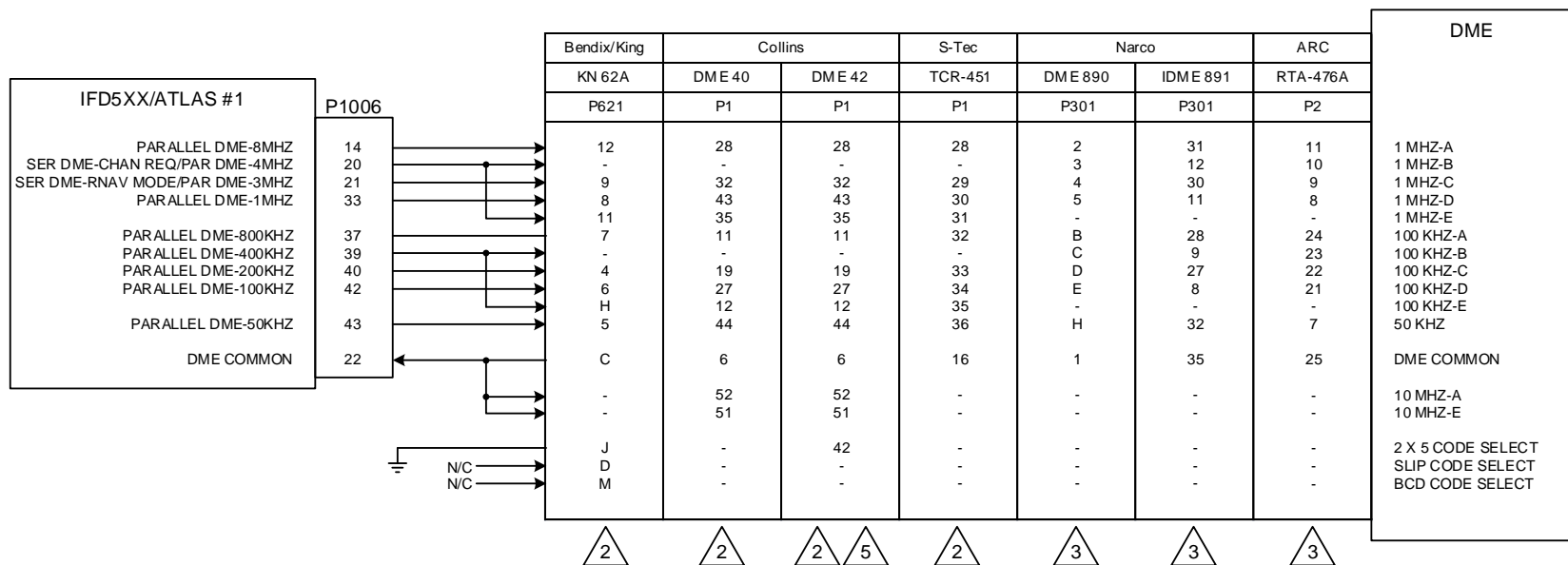

NOTES:

1. ALL WIRES TO BE 24 AWG OR GREATER UNLESS OTHERWISE NOTED.
2. THE IFD5XX/ATLAS MUST BE CONFIGURED FOR PARALLEL 2X5 DME CHANNELING MODE FOR PROPER OPERATION WITH THIS MODEL OF DME TRANSCEIVER.
3. THE IFD5XX/ATLAS MUST BE CONFIGURED FOR NARCO 890/891 DME CHANNELING MODE FOR PROPER OPERATION WITH THIS MODEL OF DME TRANSCEIVER.
4. REFER TO MANUFACTURER'S DOCUMENTATION FOR COMPLETE PINOUT AND INTERCONNECT INFORMATION. PINOUTS OF OTHER UNITS SHOWN FOR REFERENCE ONLY.
5. DME 42 MUST BE STRAPPED FOR 2X5 TUNING. REFER TO DME 42 INSTALLATION MANUAL FOR STRAPPING INFORMATION.
6. NOT APPLICABLE FOR IFD410/510/545 OR ATLAS FMS ONLY UNITS

Figure D - 24: Parallel DME Tuning Interconnect

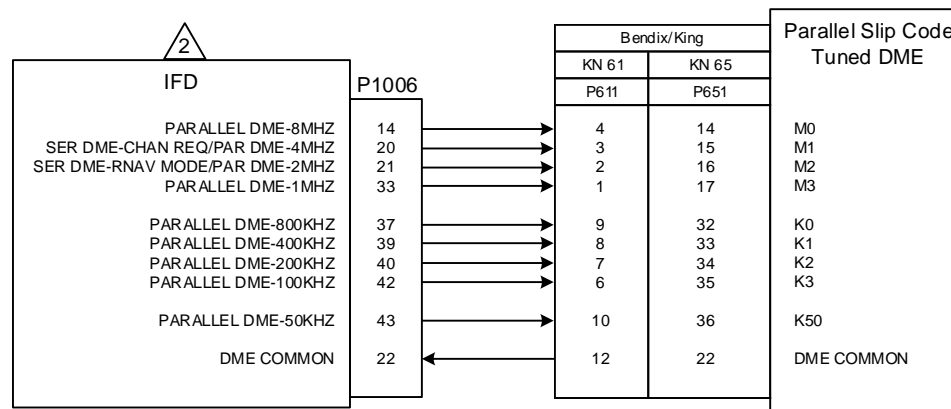

NOTES:

1. ALL WIRES TO BE 22 AWG OR GREATER UNLESS OTHERWISE NOTED.
2. THE IFD MUST BE CONFIGURED TO OUTPUT SLIP CODE DME TUNING DATA FOR PROPER OPERATION IN THIS CONFIGURATION.
3. REFER TO MANUFACTURER'S DOCUMENTATION FOR COMPLETE PINOUT AND INTERCONNECT INFORMATION. PINOUTS OF OTHER UNITS SHOWN FOR REFERENCE ONLY.
4. NOT APPLICABLE FOR IFD410/510/545 OR ATLAS FMS ONLY UNITS

Figure D - 25: Parallel DME Tuning Interconnect

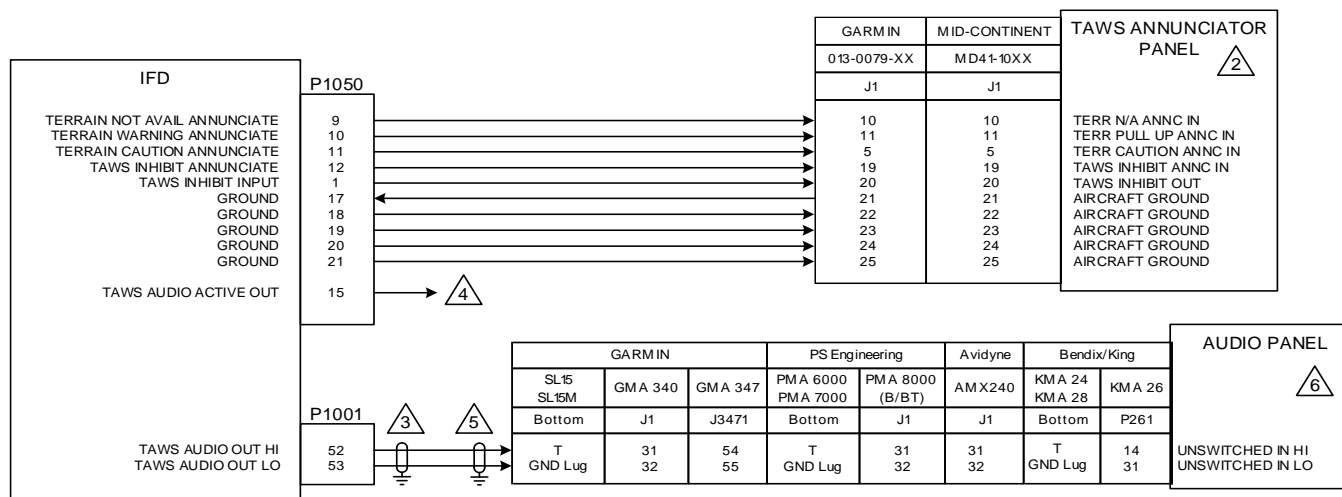

NOTES:

- ALL WIRES TO BE 22 AWG OR GREATER UNLESS OTHERWISE NOTED.
- THE FORWARD LOOKING TERRAIN ALERTING ON THE IFD DOES NOT SATISFY ANY PART 91/135 REQUIREMENT FOR A TAWS SYSTEM. INSTALLING AN EXTERNAL ANNUNCIATOR IS NOT REQUIRED. **TSO'D TAWS-B IS AVAILABLE AS A PAID OPTION FOR IFD 5XX AND ATLAS UNITS WITH SOFTWARE RELEASE 10.3.0.2 OR GREATER.** IF FIXED WING TAWS-B IS ENABLED, EXTERNAL ANNUNCIATORS **ARE** REQUIRED IF THE IFD DOES NOT MEET THE FIELD OF VIEW REQUIREMENTS LISTED IN SECTION 5.1 OF THIS MANUAL.
- WHEN TWO TAWS-EQUIPPED UNITS ARE INSTALLED IN AN AIRCRAFT, ONLY ONE SHOULD UTILIZE P1001-52/53 TO AVOID COMPETING AUDIO MESSAGES.
- CONNECT TO THE AUDIO INHIBIT INPUTS OF OTHER SYSTEMS WITH LOWER PRIORITY AURALS THAN TAWS. THIS CONNECTOR IS NOT AVAILABLE ON THE IFD4XX.
- SHIELDS FOR AUDIO CABLES SHOULD BE GROUNDED AT ONE END (WITH LEADS LESS THAN 3.0 INCHES) AND LEFT FLOATING AT THE OTHER END. IF SHIELDED AUDIO CABLE IS CARRIED THROUGH A DISCONNECT, CARRY SHIELD GROUND THROUGHOUT DISCONNECT ON A SEPARATE PIN.
- OTHER UNSWITCHED INPUTS ON THE AUDIO PANEL MAY BE USED IN LIEU OF THOSE SHOWN. THESE CONNECTIONS ARE OPTIONAL FOR FLTA, BUT **REQUIRED** FOR FIXED WING TAWS-B ENABLEMENT.
- REFER TO MANUFACTURER'S DOCUMENTATION FOR COMPLETE PINOUT AND INTERCONNECT INFORMATION. PINOUTS OF OTHER UNITS SHOWN FOR REFERENCE ONLY.

Figure D - 26: TAWS Interconnect

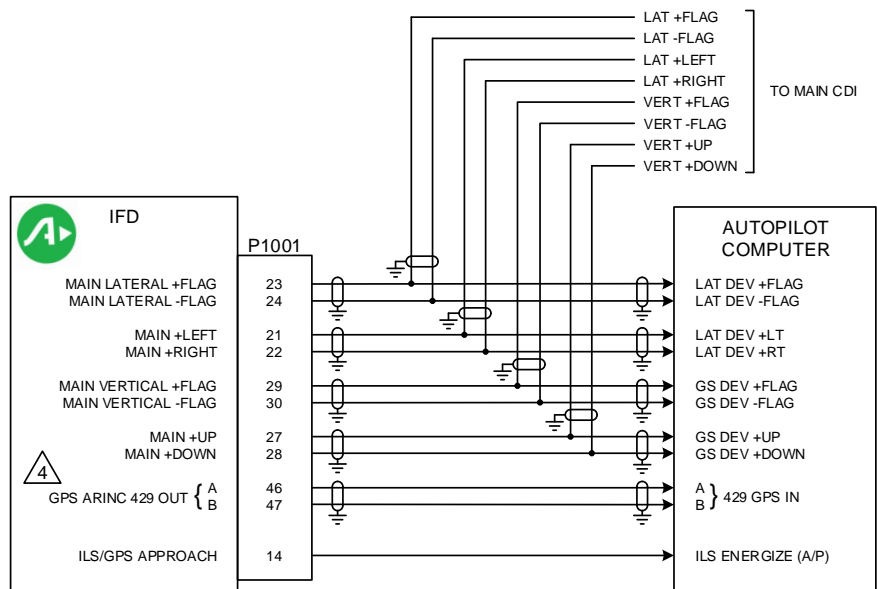

NOTES:

1. ALL WIRES TO BE 22 AWG OR GREATER UNLESS OTHERWISE NOTED.
2. AT IFD UNIT, TERMINATE SHIELD GROUNDS TO THE CONNECTOR BACKSHELL OR USE CARD-EDGE CONNECTOR TO TERMINATE SHIELD GROUNDS TO BACK PLATE – THE SHIELD LEADS MUST BE LESS THAN 3.0 INCHES. CONNECT OTHER SHIELD GROUNDS TO AIRCRAFT CHASSIS WITH AS SHORT A CONDUCTOR AS PRACTICAL.
3. ONLY CONNECTIONS SUPPORTED BY THE AUTOPILOT ARE REQUIRED.

4 ALL "GAMA 429" CONFIGURATIONS OF THE GPS ARINC 429 OUTPUT PROVIDE DATA REQUIRED BY THE AUTOPILOT FOR GPSS. DO NOT USE ANY OF THE "ARINC 429" CONFIGURATION SELECTIONS.

Figure D - 27: Autopilot Interconnect

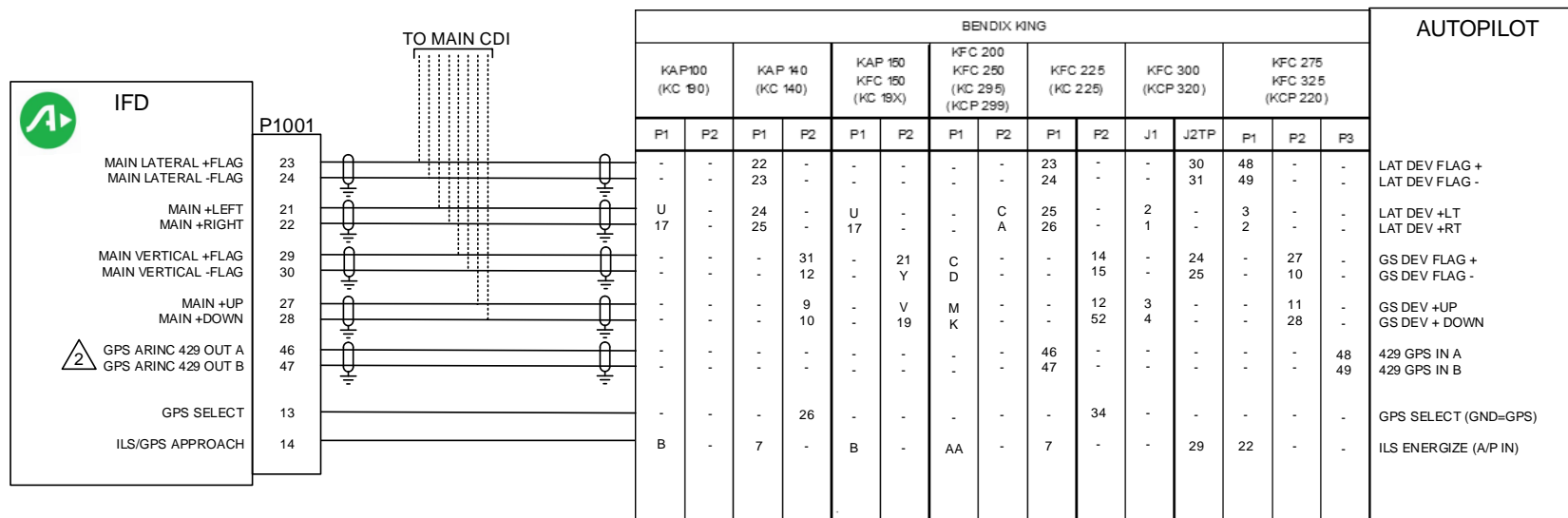

NOTES:

1. ALL WIRES TO BE 22 AWG OR GREATER UNLESS OTHERWISE NOTED.
2. ALL "GAMA 429" CONFIGURATIONS OF THE GPS ARINC 429 OUTPUT PROVIDE DATA REQUIRED BY THE AUTOPILOT FOR GPSS. DO NOT USE ANY OF THE "ARINC 429" CONFIGURATION SELECTIONS.
3. IF AN EFIS SYSTEM IS INSTALLED, NOT ALL OF THE CONNECTIONS SHOWN ARE REQUIRED. SOME OF THESE AUTOPILOT SIGNALS ARE PROVIDED BY THE EFIS SYSTEM. REFER TO MANUFACTURER'S APPROVED DOCUMENTATION FOR DETAILS.

Figure D - 28: Bendix/King Autopilot Interconnect

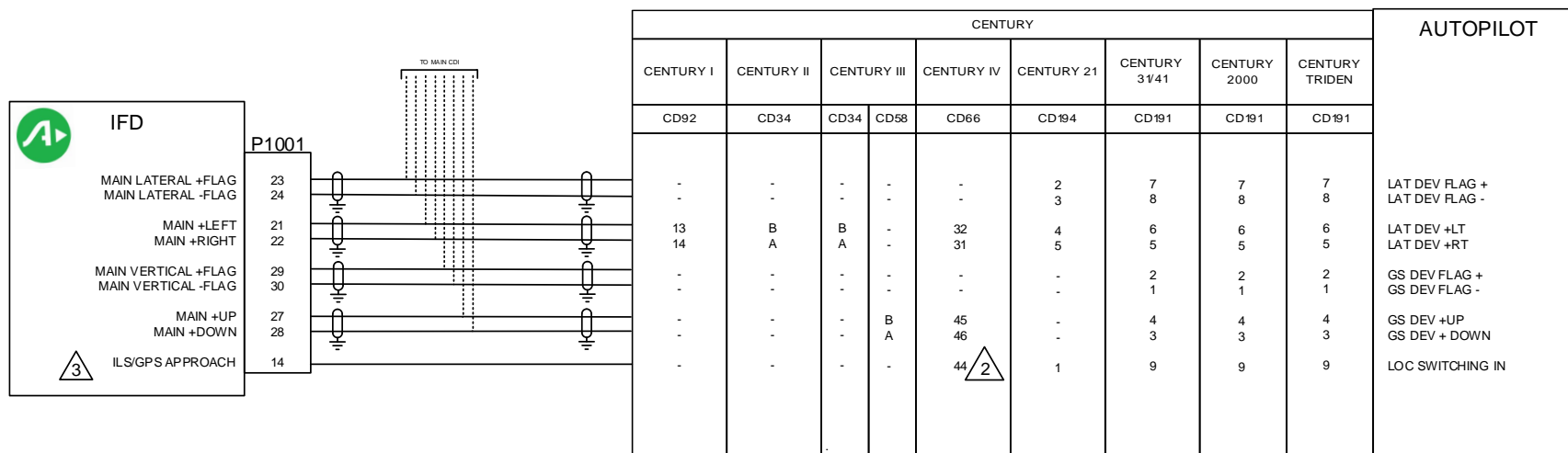
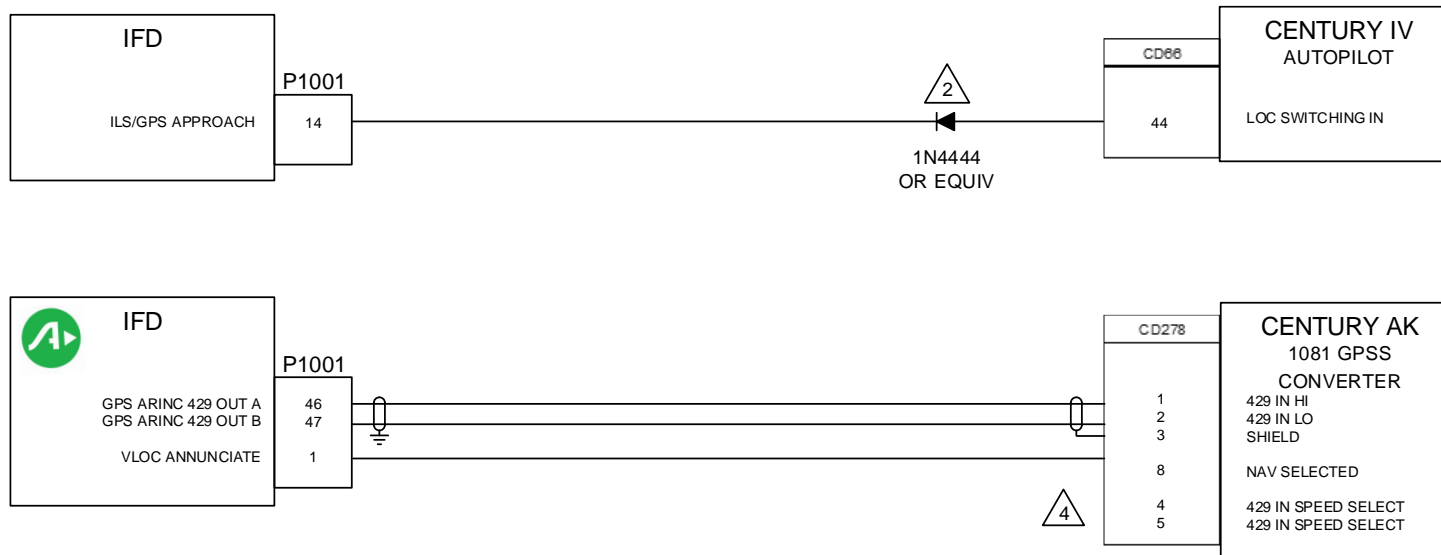

Figure D - 29: Century Autopilot Interconnect
Page 1 of 2



NOTES:



1. ALL WIRES TO BE 22 AWG OR GREATER UNLESS OTHERWISE NOTED.
-  THE CENTURY IV REQUIRES THAT AN ISOLATION DIODE BE INSTALLED ON THE LOC SWITCHING INPUT AS SHOWN.
-  SETUP ITEMS, MAIN SYSTEM CONFIG PAGE: GPS SELECT: AUTO
-  INSTALL JUMPER AS REQUIRED TO SET AK 1081 ARINC 429 INPUT SPEED TO MATCH IFD OUTPUT SETTING. REFER TO MANUFACTURER'S DOCUMENTATION FOR ADDITIONAL DETAILS.

Figure D - 30: Century Autopilot Interconnect
Page 2 of 2

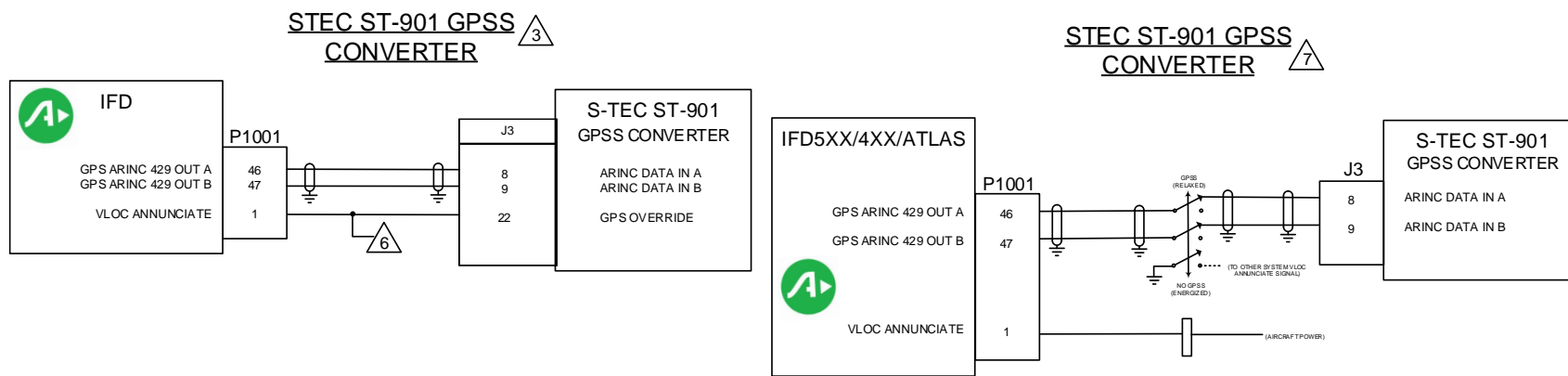
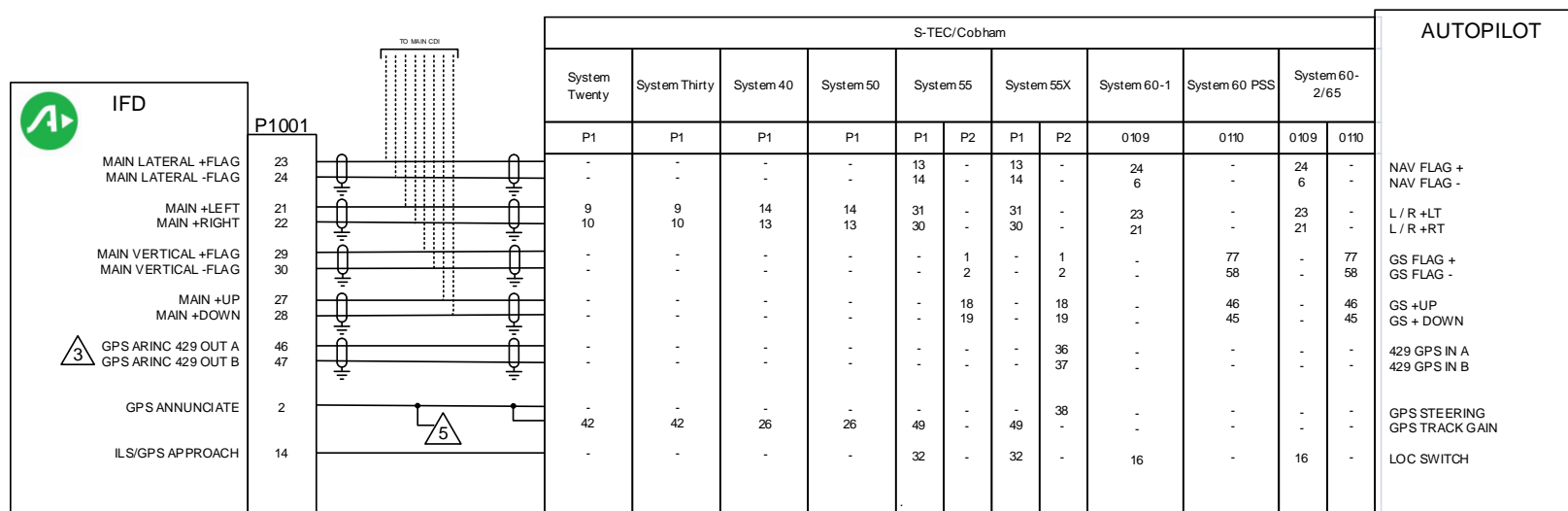
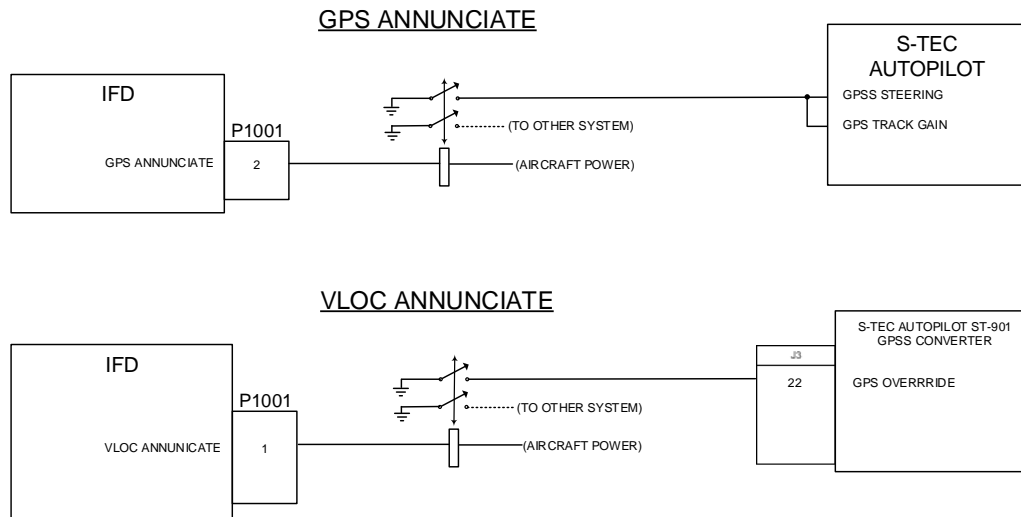

Figure D - 31: S-Tec Autopilot Interconnect
Sheet 1 of 2



NOTES:

1. ALL WIRES TO BE 22 AWG OR GREATER UNLESS OTHERWISE NOTED.
2. IF THE GPSS UNIT HAS AUTOMATIC LINE SPEED DETECTION THE IFD OUTPUT SHOULD BE SET TO LOW SPEED. REFER TO MANUFACTURER'S DOCUMENTATION FOR DETAILS.
3. FOR CONVERTERS 01278-() S/N 600A AND ABOVE.
4. INSTALL JUMPER AS REQUIRED TO SET AK 1081 ARINC 429 INPUT SPEED TO MATCH IFD OUTPUT SETTING. REFER TO MANUFACTURER'S DOCUMENTATION FOR ADDITIONAL DETAILS.
5. IF THE GPS ANNUNCIATE SIGNAL IS ONLY USED BY THE AUTOPILOT, THIS MAY BE CONNECTED DIRECTLY.
6. IF THE VLOC ANNUNCIATE SIGNAL IS ONLY USED BY THE AUTOPILOT, THIS MAY BE CONNECTED DIRECTLY.
7. FOR CONVERTERS 01278-() 599 AND BELOW.

**Figure D -31: S-Tec Autopilot Interconnect
Sheet 2 of 2**

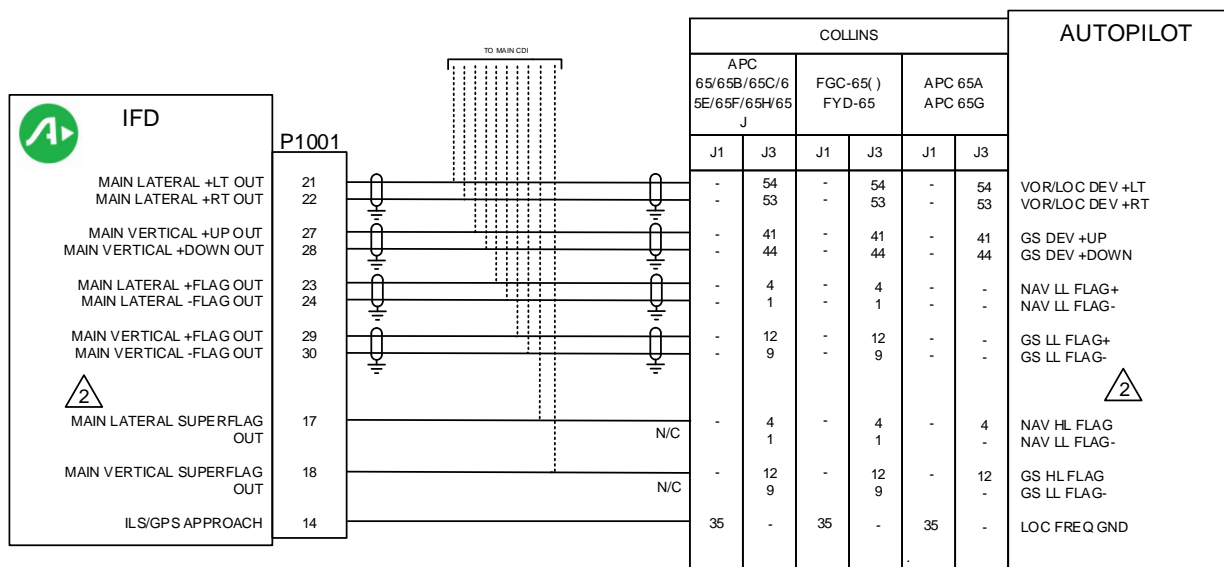

NOTES:

1. ALL WIRES TO BE 22 AWG OR GREATER UNLESS OTHERWISE NOTED.

2. CONNECT EITHER THE LOW-LEVEL FLAGS OR THE SUPERFLAGS. DO NOT CONNECT BOTH SETS OF FLAGS IN A PARTICULAR INSTALLATION

Figure D - 32: Collins Autopilot Interconnect

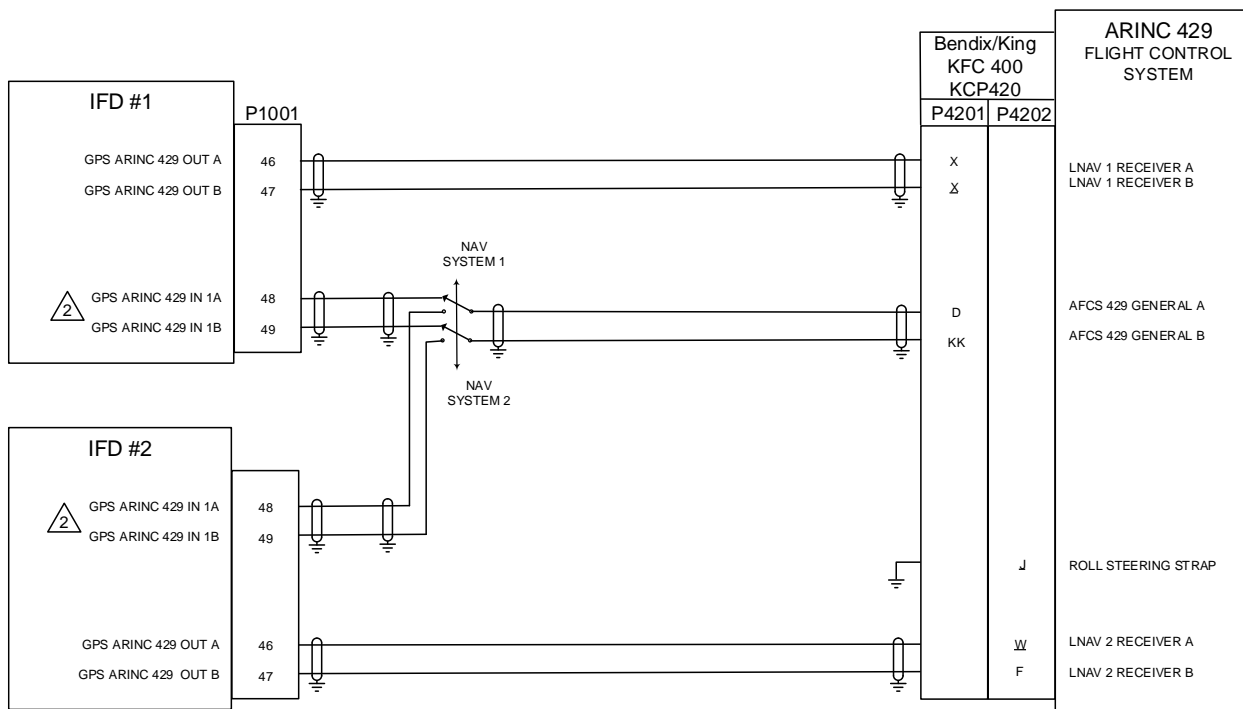

NOTES:

1. ALL WIRES TO BE 22 AWG OR GREATER UNLESS OTHERWISE NOTED.
2. IF THE GPS ARINC 429 IN PORT 1 IS ALREADY BEING USED, GPS ARINC PORT MAY BE USED.
3. LOWER CASE LETTERS SHOWN UNDERLINED.
4. REFER TO MANUFACTURERS' DOCUMENTATION FOR COMPLETE PINOUT AND INTERCONNECT INFORMATION.

Figure D - 33: Bendix King KFC400 Autopilot Interconnect

STACO INDICATOR CONNECTION 

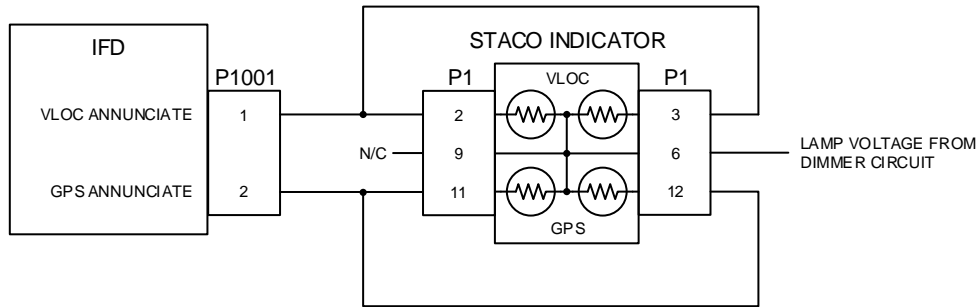

VIVISUN INDICATOR CONNECTION 

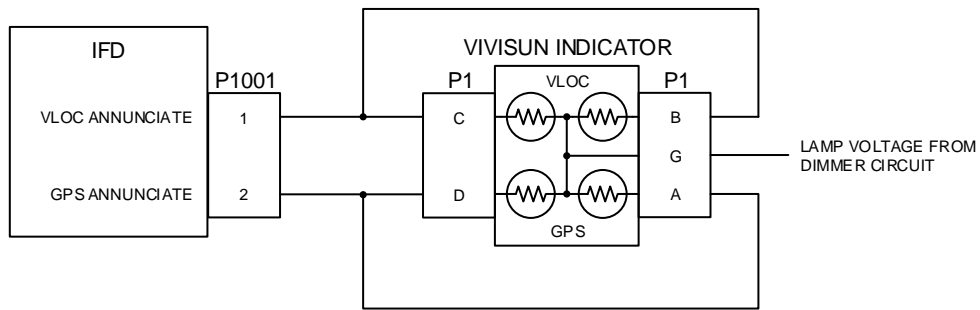

VIVISUN INDICATOR/SWITCH CONNECTION 

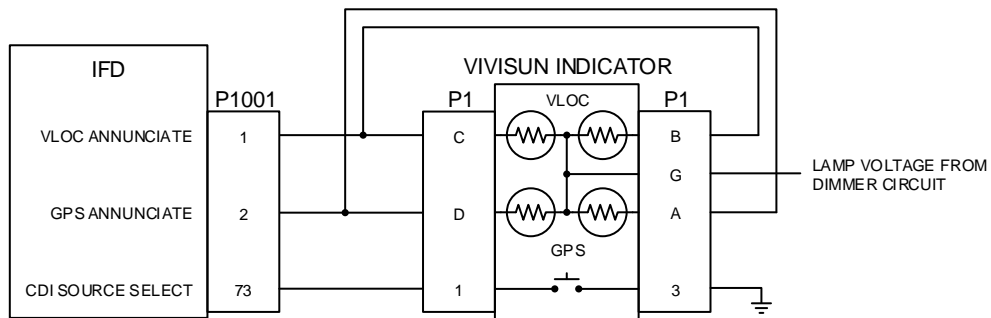
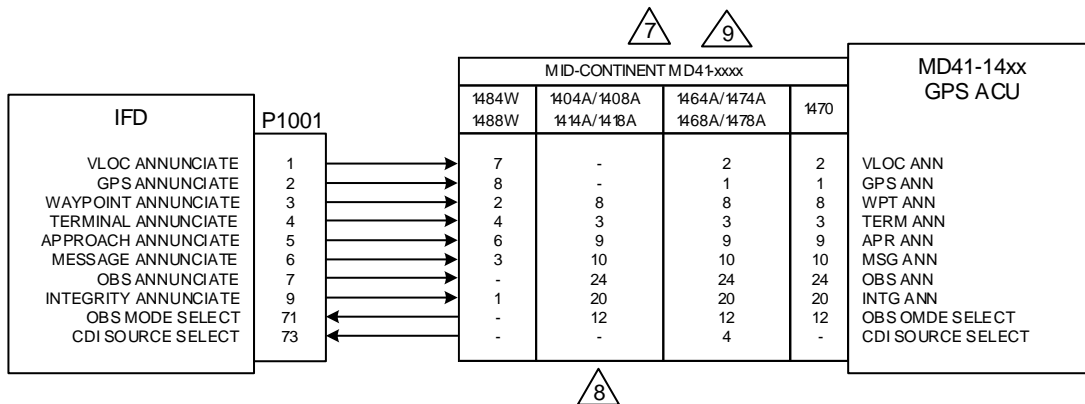

Figure D - 34: External Navigation Source and GPS Annunciators Interconnect
 Page 1 of 2



NOTES:

1. ALL WIRES TO BE 24 AWG OR GREATER UNLESS OTHERWISE NOTED.
2. IF NAVIGATION ANNUNCIATORS IS REQUIRED, INDICATORS ON THIS PAGE ARE SUITABLE TO MEET THE ANNUNCIATION REQUIREMENT.
3. THE PREFERRED ANNUNCIATION IS VLOC/GPS, ALTHOUGH NAV/GPS WILL BE ACCEPTABLE.
4. STACO SWITCH INDICATOR P/N 992561-1241762200 (14V SYSTEMS) AND P/N 992561-1241862200 (28V SYSTEMS) SHOWN.
5. VIVISUN INDICATOR P/N 95-40-17-B6-AW724 (28V SYSTEMS) SHOWN. INDICATOR MAY BE CONVERTED TO 14V OPERATION BY REPLACING 28V LAMPS WITH 14V LAMPS P/N 14-113.
6. VIVISUN INDICATOR WITH MOMENTARY SWITCH P/N 95-45-11-B6-AW724 (28V SYSTEMS) SHOWN. INDICATOR MAY BE CONVERTED TO 14V OPERATION BY REPLACING 28V LAMPS WITH 14V LAMPS P/N 14-113.
7. THESE UNITS ALSO PROVIDE NAVIGATION SOURCE SELECTION ANNUNCIATION. MID-CONTINENT ANNUNCIATION CONTROL UNITS FOR BOTH 14V AND 28V SYSTEMS SHOWN. THIS DIAGRAM IS PROVIDED TO SHOW INTERCONNECTION BETWEEN IFD540 AND ACU ONLY. REFER TO MID-CONTINENT INSTALLATION MANUAL FOR ADDITIONAL INSTALLATION INFORMATION.
8. CDI SOURCE SELECTION AND ANNUNCIATION IS DONE WITH EXTERNAL RELAYS. REFER TO MID-CONTINENT INSTALLATION MANUAL FOR ADDITIONAL INSTALLATION INFORMATION.
9. 5VDC VERSIONS: 146XA(5V) OR 147XA(5V).
10. ANNUNCIATOR PART NUMBER 146X HORIZONTAL ORIENTATION. PART NUMBER 147XA ARE VERTICAL ORIENTATION

Figure D -34: External Navigation Source and GPS Annunciators Interconnect
Page 2 of 2

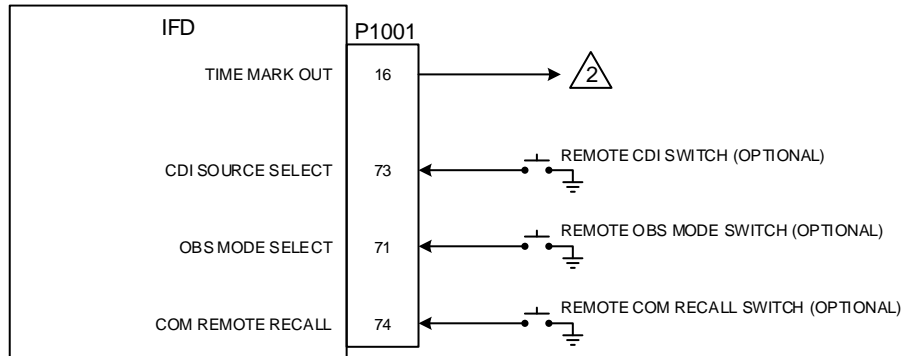

NOTES:



1. ALL WIRES TO BE 22 AWG OR GREATER UNLESS OTHERWISE NOTED.
- 
 TIME MARK OUT (P1001-16) OUTPUTS A 1 MILLISECOND WIDE PULSE ONCE PER SECOND.
3. COM REMOTE RECALL (P1001-74) INPUT MAY BE USED TO SCROLL THROUGH A LIST OF PRESET COM FREQUENCIES.

Figure D - 35: Switch Interconnect

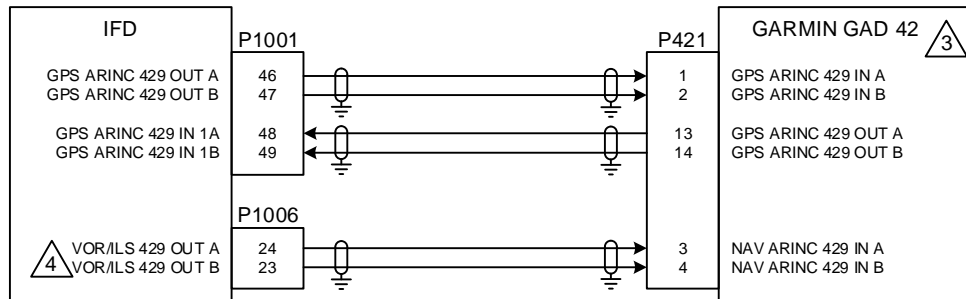

NOTES:

1. ALL WIRES TO BE 22 AWG OR GREATER UNLESS OTHERWISE NOTED.
2. AT IFD UNIT, TERMINATE SHIELD GROUNDS TO THE CONNECTOR BACKSHELL OR USE CARD-EDGE CONNECTOR TO TERMINATE SHIELD GROUNDS TO BACK PLATE – THE SHIELD LEADS MUST BE LESS THAN 3.0 INCHES. CONNECT OTHER SHIELD GROUNDS TO AIRCRAFT CHASSIS WITH AS SHORT A CONDUCTOR AS PRACTICAL.

 SEE GARMIN GAD 42 INSTALLATION MANUAL FOR COMPLETE PIN-OUT AND INTERCONNECTION INFORMATION. GAD42 MUST BE CONFIGURED USING STRAPS ON THE UNIT.

 NOT APPLICABLE FOR IFD410/510/545 OR ATLAS FMS ONLY UNITS

Figure D - 36: Garmin GAD 42 Interconnect



NOTES:

1. ALL WIRES TO BE 22 AWG OR GREATER UNLESS OTHERWISE NOTED.
 2. AT IFD UNIT, TERMINATE SHIELD GROUNDS TO THE CONNECTOR BACKSHELL OR USE CARD-EDGE CONNECTOR TO TERMINATE SHIELD GROUNDS TO BACK PLATE – THE SHIELD LEADS MUST BE LESS THAN 3.0 INCHES. CONNECT OTHER SHIELD GROUNDS TO AIRCRAFT CHASSIS WITH AS SHORT A CONDUCTOR AS PRACTICAL.
 3. REFER TO THE MANUFACTURER'S DOCUMENTATION FOR COMPLETE PIN-OUT AND INTERCONNECT INFORMATION. PIN-OUTS OF OTHER UNITS SHOWN FOR REFERENCE ONLY.
 4. FOR PROPER SETUP TO INTERFACE WITH THE G600. REFER TO THE G600 INSTALLATION MANUAL.
 6. FOR OTHER CONNECTION OPTIONS REFER TO THE G600 INSTALLATION MANUAL.
-  NOT APPLICABLE FOR IFD410/510/545 OR ATLAS FMS ONLY UNITS

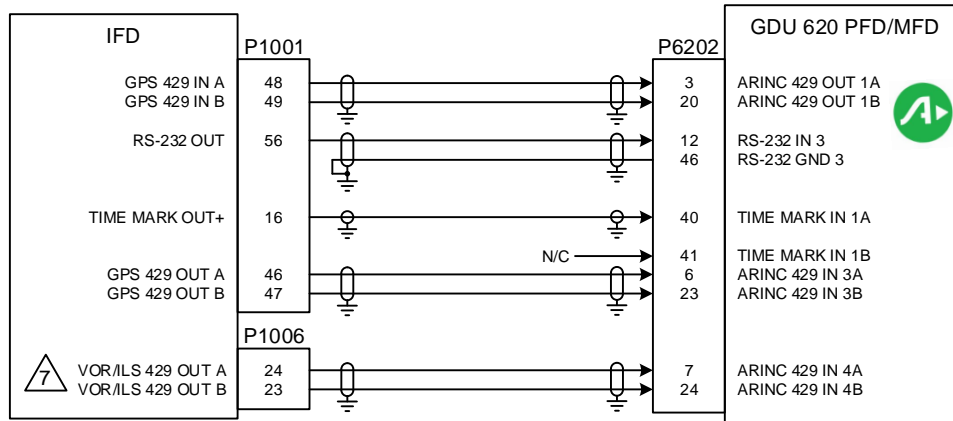
Figure D - 37: Garmin G600 Interconnect



NOTES:

1. ALL WIRES TO BE 22 AWG OR GREATER UNLESS OTHERWISE NOTED.
2. AT IFD UNIT, TERMINATE SHIELD GROUNDS TO THE CONNECTOR BACKSHELL OR USE CARD-EDGE CONNECTOR TO TERMINATE SHIELD GROUNDS TO BACK PLATE.
3. WIRE HARNESS OVERBRAID IS NOT SHOWN BUT MAY BE REQUIRED.
4. REFER TO MANUFACTURER'S DOCUMENTATION FOR COMPLETE PINOUT AND INTERCONNECT INFORMATION.

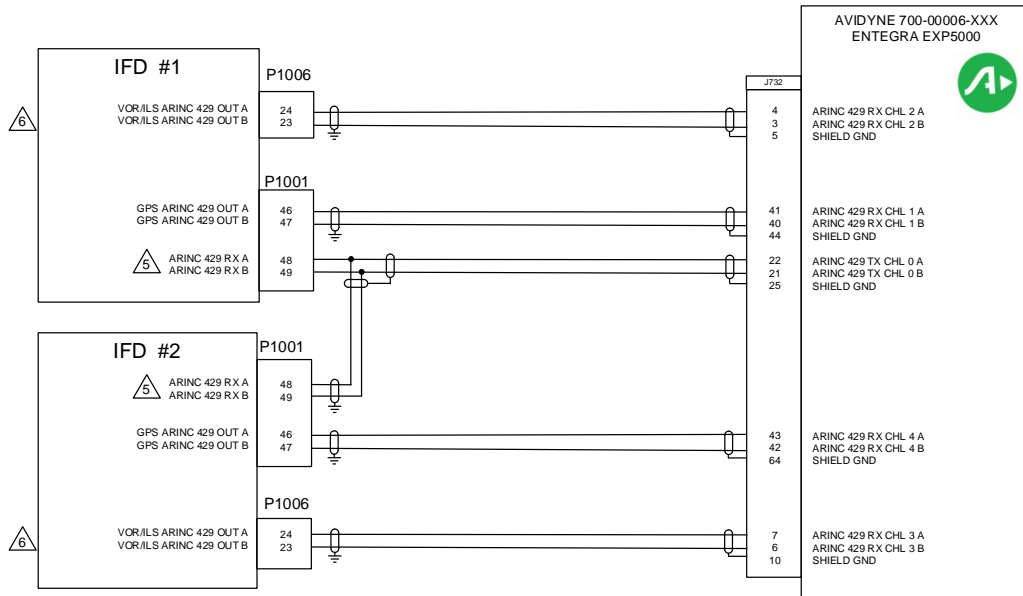
⚠️ IF THE GPS ARINC 429 IN 1 PORT (P1001-48 AND -49) IS ALREADY USED FOR ANOTHER PURPOSE, THE GPS ARINC 429 IN 2 PORT (P1001-50 AND -51) MAY BE CONNECTED INSTEAD.

⚠️ NOT APPLICABLE FOR IFD410/510/545 OR ATLAS FMS ONLY UNITS

Figure D - 38: Avidyne Entegra Interconnect

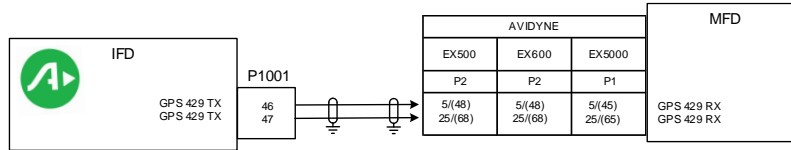

NOTES:

1. ALL WIRES TO BE 22 AWG OR GREATER UNLESS OTHERWISE NOTED.
2. AT IFD UNIT, TERMINATE SHIELD GROUNDS TO THE CONNECTOR BACKSHELL OR USE CARD-EDGE CONNECTOR TO TERMINATE SHIELD GROUNDS TO BACK PLATE.
3. WIRE HARNESS OVERBRAID IS NOT SHOWN BUT MAY BE REQUIRED.
4. REFER TO MANUFACTURER'S DOCUMENTATION FOR COMPLETE PINOUT AND INTERCONNECT INFORMATION.

Figure D - 39: Avidyne EX500/600/5000 Interconnect

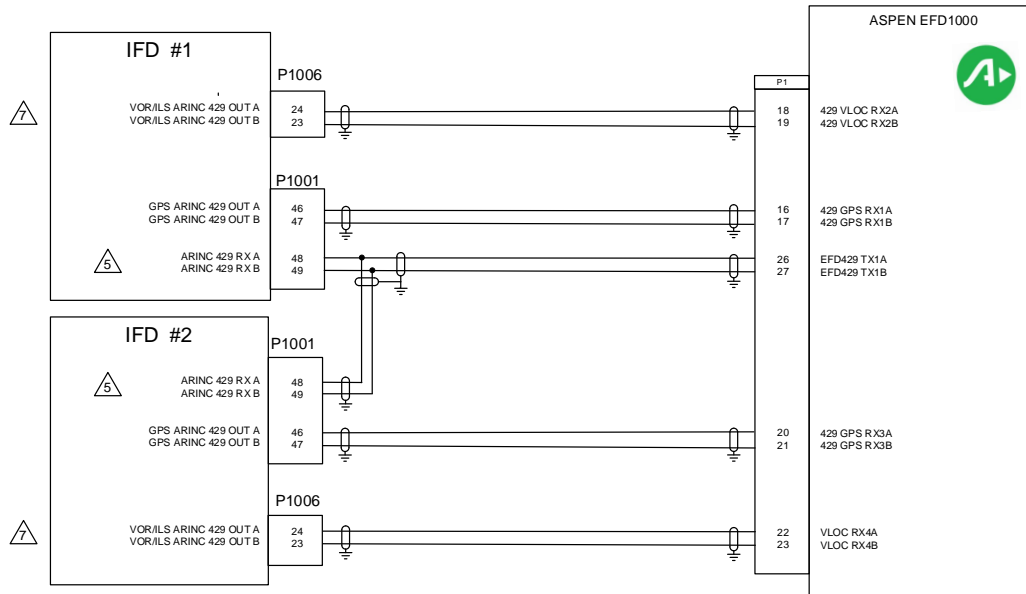

NOTES:

1. ALL WIRES TO BE 22 AWG OR GREATER UNLESS OTHERWISE NOTED.
 2. AT IFD UNIT, TERMINATE SHIELD GROUNDS TO THE CONNECTOR BACKSHELL OR USE CARD-EDGE CONNECTOR TO TERMINATE SHIELD GROUNDS TO BACK PLATE.
 3. WIRE HARNESS OVERBRAID IS NOT SHOWN BUT MAY BE REQUIRED.
 4. REFER TO MANUFACTURER'S DOCUMENTATION FOR COMPLETE PINOUT AND INTERCONNECT INFORMATION.
 5. IF THE GPS ARINC 429 IN 1 PORT (P1001-48 AND -49) IS ALREADY USED FOR ANOTHER PURPOSE, THE GPS ARINC 429 IN 2 PORT (P1001-50 AND -51) MAY BE CONNECTED INSTEAD.
 6. REFER TO MANUFACTURER'S INSTALL MANUAL FOR AIRDATA CONNECTION. ASPEN EFD1000 S/W 2.X OR LATER WILL TRANSMIT AIRDATA ON THE ARINC 429 TRANSMIT.
- NOT APPLICABLE FOR IFD410/510/545 OR ATLAS FMS ONLY UNITS

Figure D - 40: Aspen EFD1000 Interconnect (without ACU)

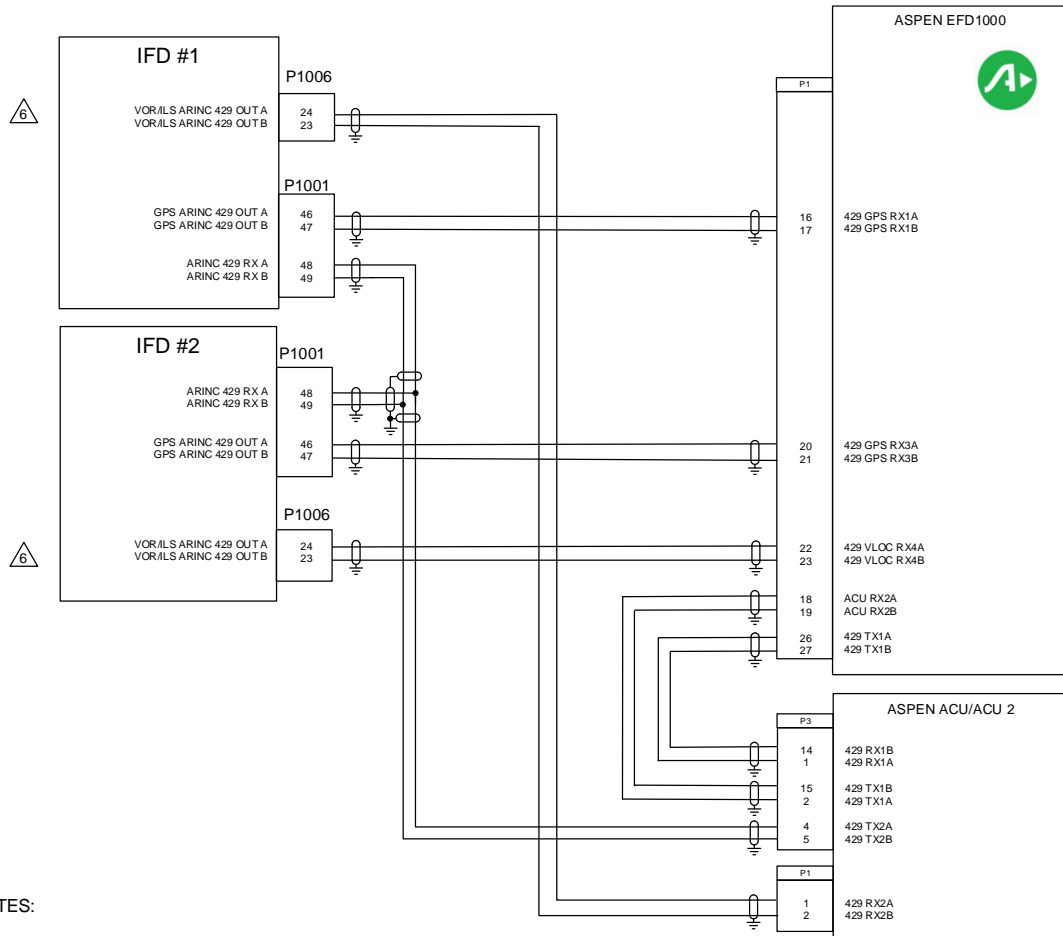
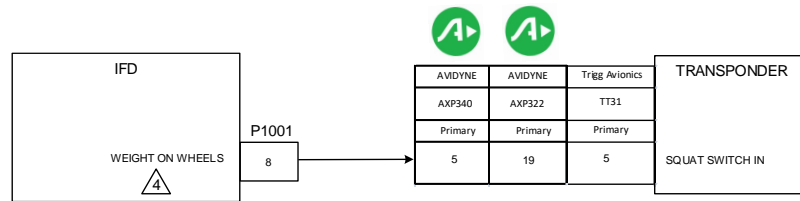

Figure D - 41: Aspen EFD1000 Interconnect (with ACU)



NOTES:

1. ALL WIRES TO BE 22 AWG OR GREATER UNLESS OTHERWISE NOTED.
2. WIRE HARNESS OVERBRAID IS NOT SHOWN BUT MAY BE REQUIRED.
3. REFER TO MANUFACTURER'S DOCUMENTATION FOR COMPLETE PINOUT AND INTERCONNECT INFORMATION.

⚠️ 4 IF THE AIRCRAFT HAS AN EXISTING WEIGHT ON WHEELS OUTPUT, DO NOT CONNECT.

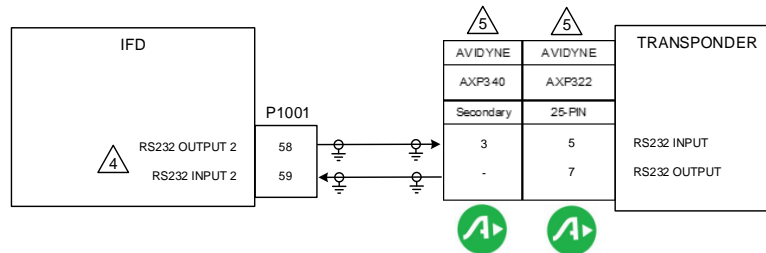

NOTES:

1. ALL WIRES TO BE 22 AWG OR GREATER UNLESS OTHERWISE NOTED.
 2. WIRE HARNESS OVERBRAID IS NOT SHOWN BUT MAY BE REQUIRED.
 3. REFER TO MANUFACTURER'S DOCUMENTATION FOR COMPLETE PINOUT AND INTERCONNECT INFORMATION.
- ⚠️ 4 IF RS-232 PORT 2 IS NOT AVAILABLE, USE ANY OTHER AVAILABLE PORT EXCEPT RS232 PORT 3, RESERVED FOR CROSS-SYNCH ONLY.
- ⚠️ 5 ADS-B OUTPUT REQUIRES A SEPARATE INSTALLATION APPROVAL.

Figure D - 42: Transponder Interconnect

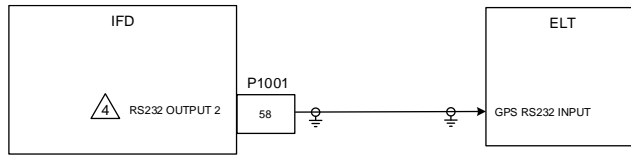

NOTES:

1. ALL WIRES TO BE 22 AWG OR GREATER UNLESS OTHERWISE NOTED.
 2. WIRE HARNESS OVERBRAID IS NOT SHOWN BUT MAY BE REQUIRED.
 3. REFER TO MANUFACTURER'S DOCUMENTATION FOR COMPLETE PINOUT AND INTERCONNECT INFORMATION.
- ⚠ IF RS-232 PORT 2 IS NOT AVAILABLE, USE ANY OTHER AVAILABLE PORT EXCEPT RS232 PORT 3, RESERVED FOR CROSS-SYNCH ONLY.

Figure D - 43: ELT Interconnect

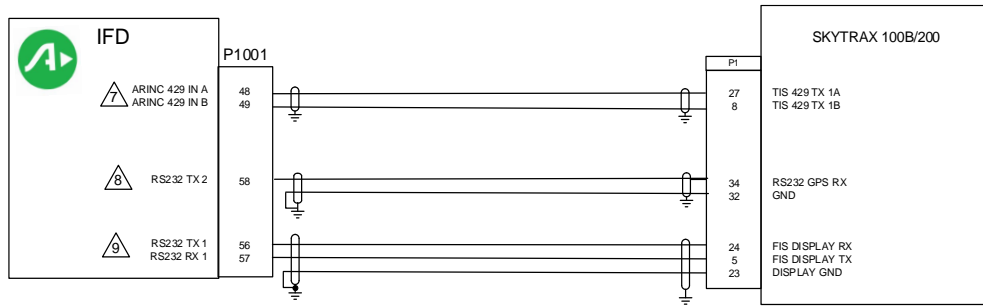

NOTES:

1. ALL WIRES TO BE 22 AWG OR GREATER UNLESS OTHERWISE NOTED.
 2. AT IFD UNIT, TERMINATE SHIELD GROUNDS TO THE CONNECTOR BACKSHELL OR USE CARDEDGE CONNECTOR TO TERMINATE SHIELD GROUNDS TO BACK PLATE.
 3. WIRE HARNESS OVERBRAID IS NOT SHOWN BUT MAY BE REQUIRED.
 4. REFER TO MANUFACTURER'S DOCUMENTATION FOR COMPLETE PINOUT AND INTERCONNECT INFORMATION.
 5. IF RS232 OR ARINC429 PORTS ARE UNAVAILABLE, USE ANY OTHER AVAILABLE PORT EXCEPT RS232 PORT 3, RESERVED FOR CROSS-SYNCH ONLY.
 6. TRAFFIC DATA IS COMBINED WITH WEATHER OVER RS232 WITH SW VERSION 10.2 OR LATER. ARINC 429 CONNECTION IS NOT REQUIRED.
- ⚠ FOR IFD SW VERSION 10.1.1, 10.1.2, OR 10.1.3: CONFIGURE ARINC 429 PORT TO **MLB Traffic**, Port Speed: **High**. THIS PORT CAN BE USED IN LATER IFD SW VERSIONS.
- ⚠ CONFIGURE GPS RS232 PORT FOR **ADS-B+(G)**
- ⚠ FOR IFD SW VERSION 10.2 OR LATER; FOR NAVWORX MLB100 CONFIGURE DISPLAY RS232 PORT TO **SkyTrax100**. FOR **SkyTrax 100B/200** CONFIGURE DISPLAY RS232 PORT TO **CAPSTONE HS TRFC & WX**.

Figure D - 44: MLB100 (NavWorx) and Skytrax100B/200 ADS-B IN Receiver Interconnect

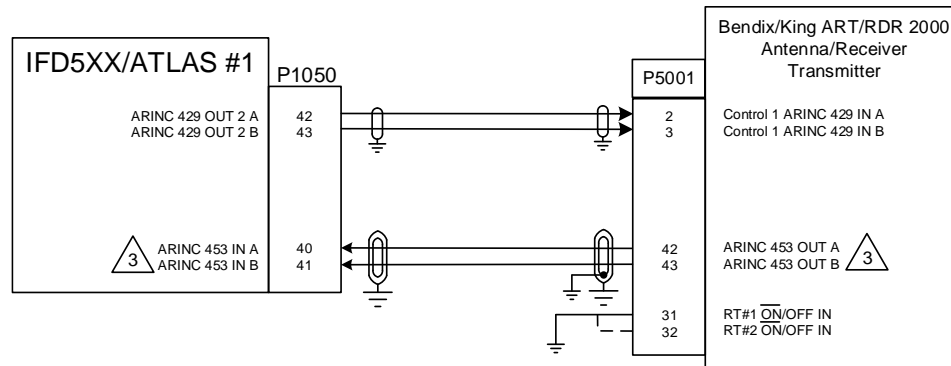

NOTES:

1. ALL WIRES TO BE 22 AWG MINIMUM UNLESS OTHERWISE SPECIFIED.
2. IN DUAL IFD5XX/ATLAS INSTALLATIONS THE RADAR CAN BE CONNECTED TO EITHER IFD. RADAR DATA IS SHARED OVER CROSSSYNC. ONLY IFD5XX/ATLAS MODELS SUPPORTS RADAR DISPLAY AND CONTROL. REQUIRES SW RELEASE 10.2.4.1 OR GREATER.
3. ARINC 453 DATA BUS: BOTH SHIELDS GROUNDED TO CONNECTOR SHELL AT ART/RDR 2000; OUTER SHIELD GROUNDED ONLY AT IFD5XX UNIT END. WIRE TO BE QUADRAX, NON-PVC JACKET, KPN: 024-00064-0000.
4. AT IFD5XX UNIT, TERMINATE SHIELD GROUNDS TO THE CONNECTOR BACKSHELL OR USE CARD-EDGE CONNECTOR TO TERMINATE SHIELD GROUNDS TO BACK PLATE – THE SHIELD LEADS MUST BE LESS THAN 3.0 INCHES. CONNECT OTHER SHIELD GROUNDS TO AIRCRAFT CHASSIS WITH AS SHORT A CONDUCTOR AS PRACTICAL
5. ALL SHIELD GROUND CONNECTIONS SHOWN FOR THE ART/RDR 2000 ARE TO BE CONNECTED TO THE UNIT BACKSHELL GROUND.
6. IFD4XX UNITS DO NOT SUPPORT RADAR DISPLAY OR CONTROL.
7. SET THE IFD ARINC 429 #2 OUT TO ONBOARD RADAR.
8. THESE ARE THE ELECTRICAL CONNECTIONS BETWEEN THE AVIDYNE IFD AND THE BENDIX / KING RDR2000 SYSTEM R/T UNITS. ALL OTHER WIRING IS AT THE DISCRETION OF THE INSTALLER.

Figure D - 45: RDR2000 Interconnect

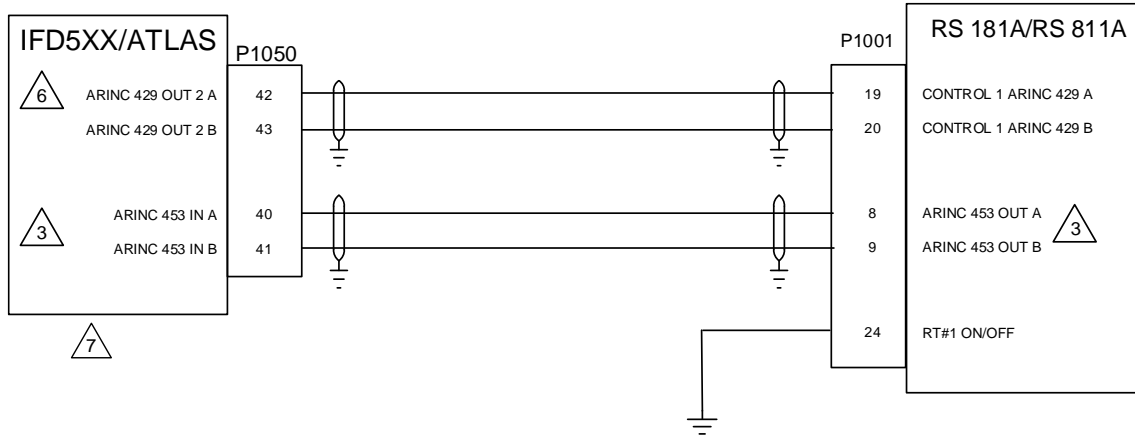

NOTES:

1. ALL WIRES TO BE 22 AWG MINIMUM UNLESS OTHERWISE SPECIFIED.
2. IN DUAL IFD5XX/ATLAS INSTALLATIONS THE RADAR CAN BE CONNECTED TO EITHER IFD. RADAR DATA IS SHARED OVER CROSSSYNC. ONLY IFD5XX/ATLAS MODELS SUPPORTS RADAR DISPLAY AND CONTROL
3. ARINC 453 DATA BUS: BOTH SHIELDS GROUNDED TO CONNECTOR SHELL AT RS ART; OUTER SHIELD GROUNDED ONLY AT IFD5XX/ATLAS UNIT END.
4. AT IFD5XX/ATLAS UNIT, TERMINATE SHIELD GROUNDS TO THE CONNECTOR BACKSHELL OR USE CARD-EDGE CONNECTOR TO TERMINATE SHIELD GROUNDS TO BACK PLATE – THE SHIELD LEADS MUST BE LESS THAN 3.0 INCHES. CONNECT OTHER SHIELD GROUNDS TO AIRCRAFT CHASSIS WITH AS SHORT A CONDUCTOR AS PRACTICAL.
5. ALL SHIELD GROUND CONNECTIONS SHOWN FOR THE RDS ART ARE TO BE CONNECTED TO THE UNIT BACKSHELL GROUND.
6. SET THE IFD ARINC 429 #2 OUT TO ONBOARD RADAR.
7. SET RADAR CONFIGURATION IN THE IFD/ATLAS AS FOLLOWS (RDS 86P SHOWN):



IN DUAL IFD INSTALLATIONS, BOTH IFD UNITS SHALL BE CONFIGURED THE SAME

8. THESE ARE THE ELECTRICAL CONNECTIONS BETWEEN THE AVIDYNE IFD/ATLAS AND THE BENDIX/KING RDS ART UNITS. ALL OTHER WIRING IS AT THE DISCRETION OF THE INSTALLER.
9. REQUIRES IFD SOFTWARE 10.3.0.2 OR LATER
10. SET 'SCAN ARC' ANGLE TO CORRESPOND TO RADAR CAPABILITY

Figure D - 46: RDS Radars Interconnect

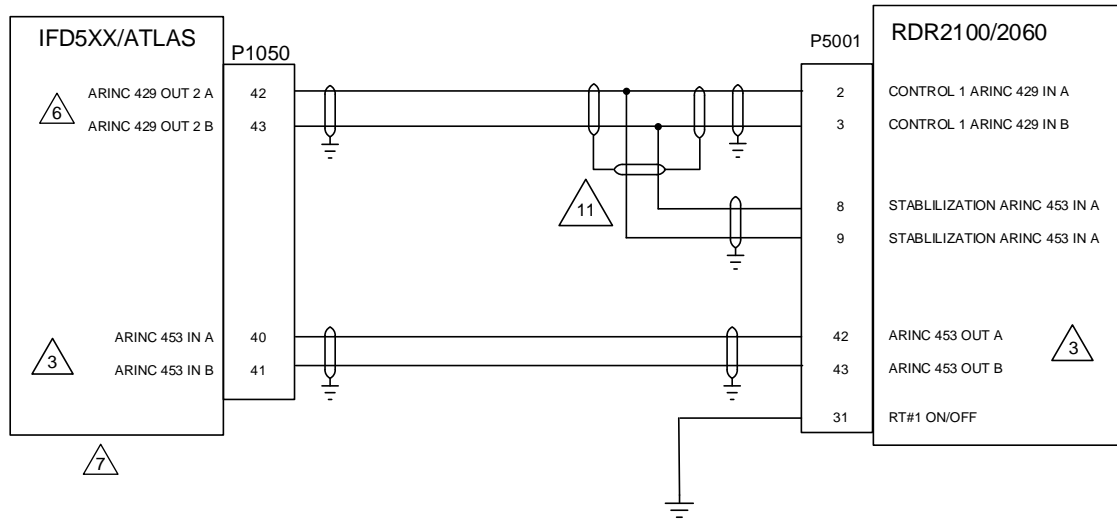

NOTES:

1. ALL WIRES TO BE 22 AWG MINIMUM UNLESS OTHERWISE SPECIFIED.
2. IN DUAL IFD5XX/ATLAS INSTALLATIONS THE RADAR CAN BE CONNECTED TO EITHER IFD . RADAR DATA IS SHARED OVER CROSSSYNC. ONLY IFD 5XX/ATLAS MODELS SUPPORTS RADAR DISPLAY AND CONTROL.
- 3 ARINC 453 DATA BUS: BOTH SHIELDS GROUNDED TO CONNECTOR SHELL AT ART/RDR; OUTER SHIELD GROUNDED ONLY AT IFD5XX/ATLAS UNIT END. WIRE TO BE QUADRAX, NON-PVC JACKET, KPN: 024-00064-0000.
4. AT IFD5XX/ATLAS UNIT, TERMINATE SHIELD GROUNDS TO THE CONNECTOR BACKSHELL OR USE CARD-EDGE CONNECTOR TO TERMINATE SHIELD GROUNDS TO BACK PLATE – THE SHIELD LEADS MUST BE LESS THAN 3.0 INCHES. CONNECT OTHER SHIELD GROUNDS TO AIRCRAFT CHASSIS WITH AS SHORT A CONDUCTOR AS PRACTICAL
5. ALL SHIELD GROUND CONNECTIONS SHOWN FOR THE ART/RDR ARE TO BE CONNECTED TO THE UNIT BACKSHELL GROUND.
- 6 SET THE IFD ARINC 429 #2 OUT TO ONBOARD RADAR.
- 7 SET RADAR CONFIGURATION AS FOLLOWS (RDR 2100 SHOWN):

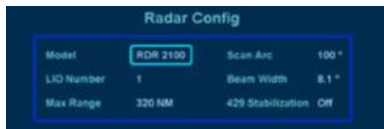

IN DUAL IFD/ATLAS INSTALLATIONS, BOTH UNITS SHALL BE CONFIGURED THE SAME

8. THESE ARE THE ELECTRICAL CONNECTIONS BETWEEN THE AVIDYNE IFD/ATLAS AND THE BENDIX / KING RDR2100/2600 SYSTEM R/T UNITS. ALL OTHER WIRING IS AT THE DISCRETION OF THE INSTALLER.
9. REQUIRES IFD/ATLAS SOFTWARE RELEASE 10.2.4.1, OR LATER
10. SET "SCAN ARC" ANGLE TO CORRESPOND TO RADAR CAPABILITY
P/N 071-01550-0101 SCAN ANGLE 90/100/120
P/N 071-01550-0201 SCAN ANGLE 90/100

Figure D - 47: RDR2100/2060 Interconnect

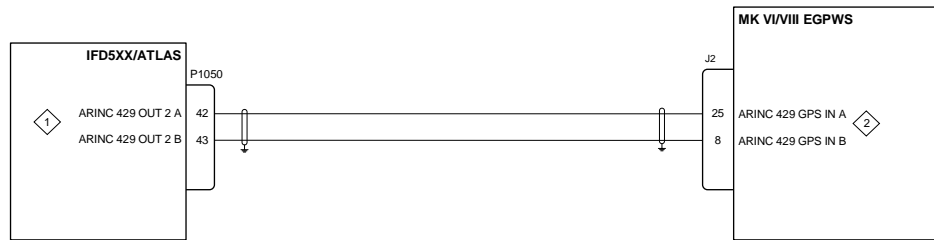

NOTES:

1. CONFIGURE MAIN ARINC 429 OUT 2 TO "ARINC 743A". SET SPEEDS TO MATCH, EGPWS CONFIG: TYPE 0 FOR LOW SPEED, TYPE 4 FOR HIGH SPEED .
2. IFD GPS ALTITUDE REFERENCE IS MSL. CONFIGURE EGPWS ALTITUDE REFERENCE TO "MSL".
3. COMPATIBLE EGPWS MK VIII PART NUMBERS (W/O INTERNAL GPS) :
 965-1206-001 to 965-1206-yyy
 965-1210-020 to 965-1210-yyy
4. COMPATIBLE EGPWS MK VI PART NUMBERS (W/O INTERNAL GPS):
 965-1176-001 to 965-1176-yyy
 965-1180-020 to 965-1880-yyy
5. IFD FLTA FEATURE MUST BE DISABLED IF INSTALLED IN AIRCRAFT WITH APPROVED TAWS/EGPWS. THIS IS ACCOMPLISHED BY SELECTING "Yes" FOR THE "External TAWS" OPTION IN THE CONFIG TAB OF MAINTENANCE MODE.

Figure D - 48: MK VI and VIII EGPWS Interconnect

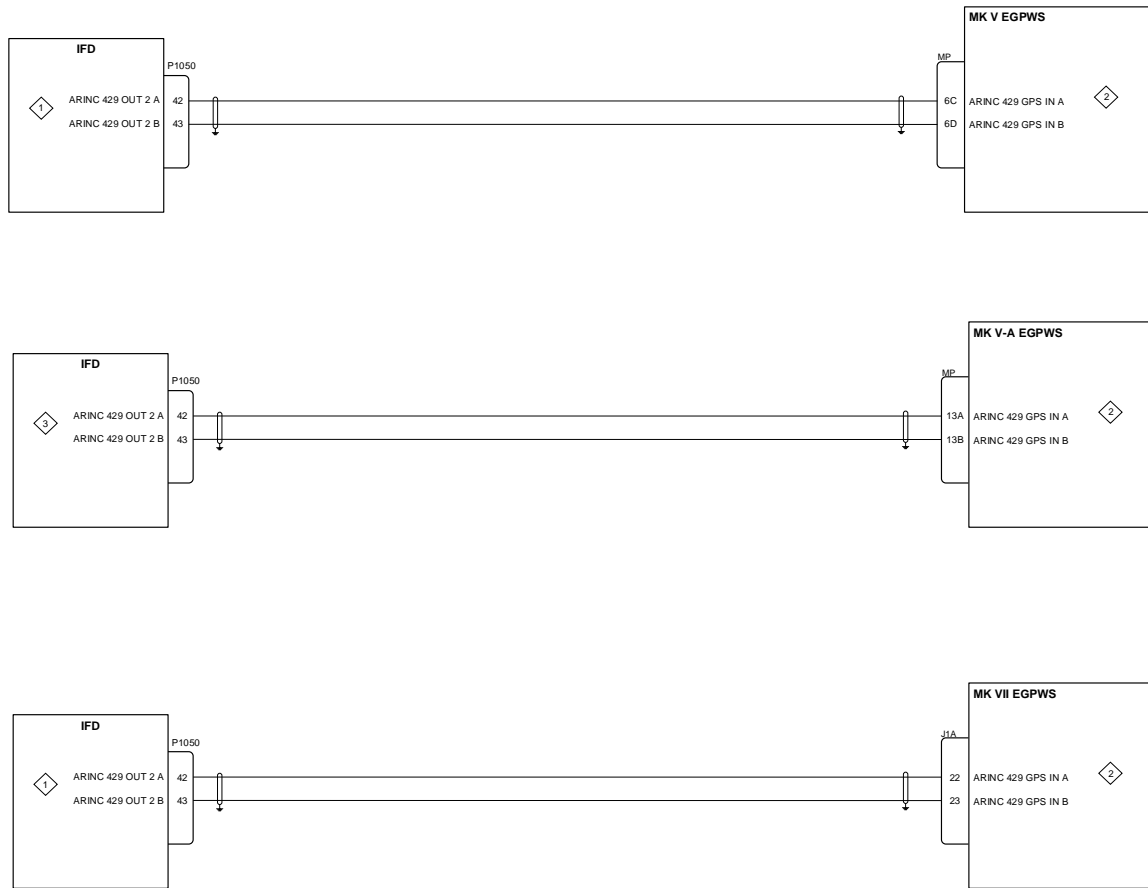

NOTES:

1. CONFIGURE IFD MAIN ARINC 429 OUT 2 TO "ARINC 743A" AND SPEED TO CORRESPOND TO EGPWS SPEED SETTING.
2. IFD GPS ALTITUDE REFERENCE IS MSL. CONFIGURE EGPWS ALTITUDE REFERENCE TO "MSL".
3. CONFIGURE IFD MAIN ARINC 429 OUT 2 TO "ARINC 743A" AND SPEED TO "HIGH".
4. COMPATIBLE EGPWS MK V PART NUMBERS (W/O INTERNAL GPS) :
 965-0976-003-210-210 to 965-0976-003-yyy-zzz
 965-0976-040-210-210 to 965-0976-040-yyy-zzz
5. COMPATIBLE EGPWS MK V-A PART NUMBERS:
 69000941-101 to 69000941-1xx
6. COMPATIBLE EGPWS MK VII PART NUMBERS (W/O INTERNAL GPS):
 965-1076-040-210-210 to 965-1076-040-yyy-zzz
7. IFD FLTA FEATURE MUST BE DISABLED IF INSTALLED IN AIRCRAFT WITH APPROVED TAWS/EGPWS. THIS IS ACCOMPLISHED BY SELECTING "Yes" FOR THE "External TAWS" OPTION IN THE CONFIG TAB OF MAINTENANCE MODE.

Figure D - 49: MK V, V-A, and VII EGPWS Interconnect

Single IFD Series

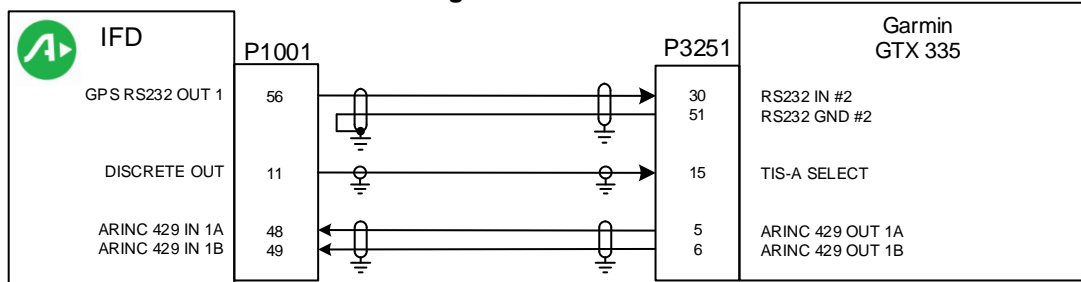

Dual IFD Series

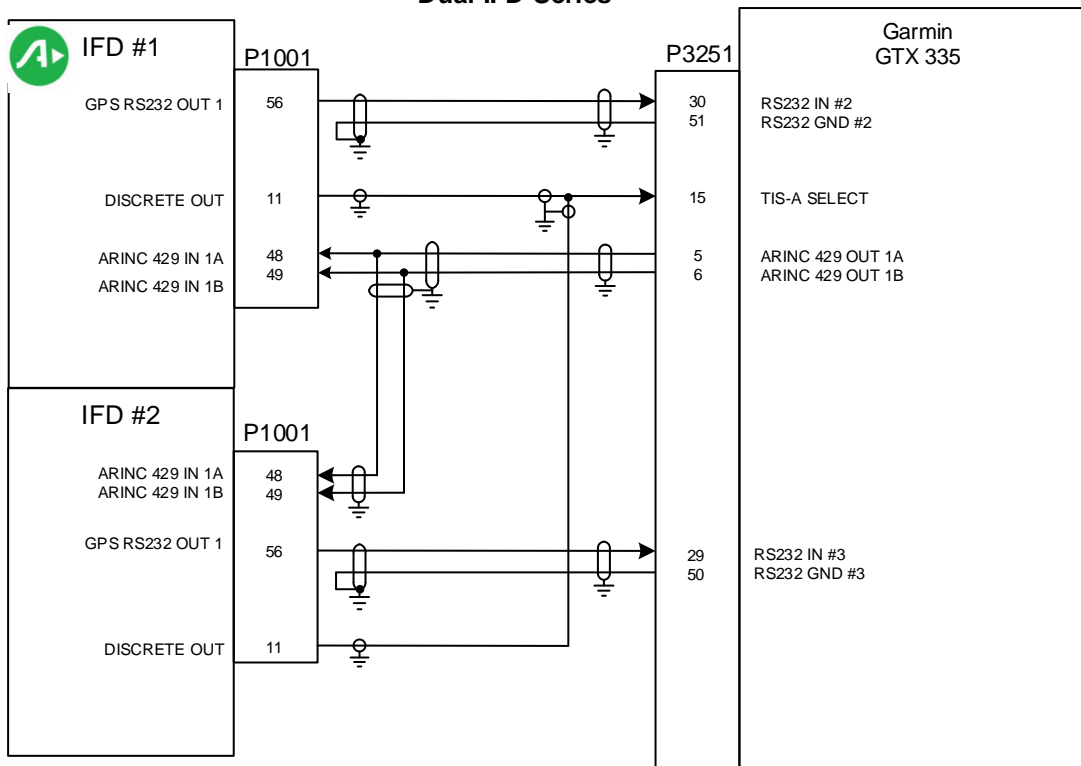

NOTES:

1. ALL WIRES TO BE 24 AWG MINIMUM UNLESS OTHERWISE SPECIFIED.
2. ALL GROUND CONNECTIONS SHOWN FOR THE GTX335 ARE TO BE CONNECTED TO SHIELD BLOCK GROUND.
3. AT IFD UNIT, TERMINATE SHIELD GROUNDS TO THE CONNECTOR BACKSHELL OR USE CARD-EDGE CONNECTOR TO TERMINATE SHIELD GROUNDS TO BACK PLATE – THE SHIELD LEADS MUST BE LESS THAN 3.0 INCHES. CONNECT OTHER SHIELD GROUNDS TO AIRCRAFT CHASSIS WITH AS SHORT A CONDUCTOR AS PRACTICAL.
4. IFD SERIAL PORTS (RS232 AND ARINC 429) OTHER THAN THE ONES SHOWN ABOVE MAY BE SUBSTITUTED WITH APPROPRIATE UNIT SOFTWARE CONFIGURATION.

Figure D - 50: GTX 335 Interconnect

Single IFD Series

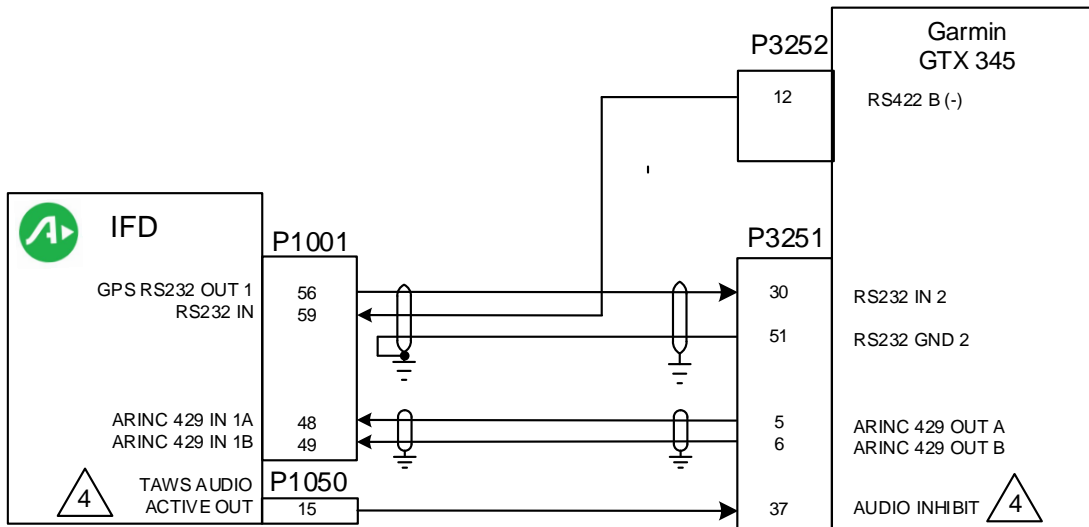

Dual IFD Series

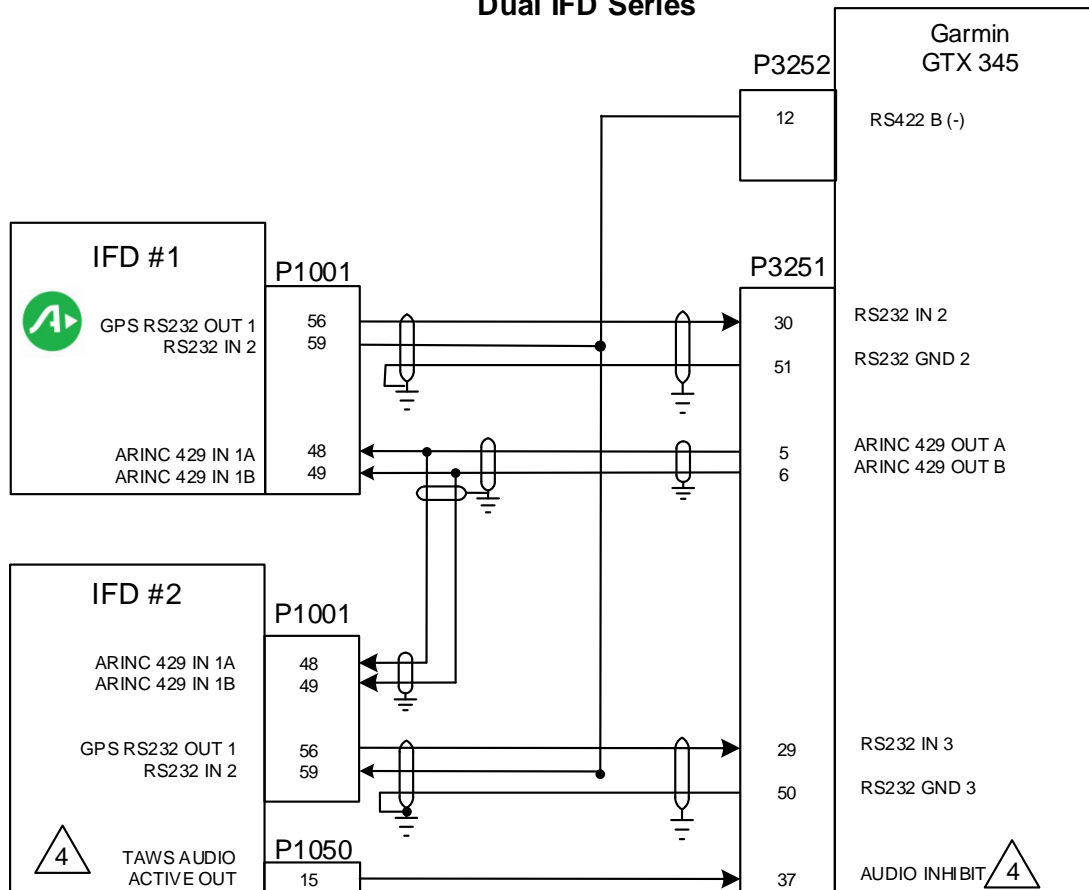

Figure D - 51: GTX 345 Interconnect

NOTES:

1. ALL WIRES TO BE 24 AWG MINIMUM UNLESS OTHERWISE SPECIFIED.
2. ALL GROUND CONNECTIONS SHOWN FOR THE GTX345 ARE TO BE CONNECTED TO SHIELD BLOCK GROUND.
3. AT IFD UNIT, TERMINATE SHIELD GROUNDS TO THE CONNECTOR BACKSHELL OR USE CARD-EDGE CONNECTOR TO TERMINATE SHIELD GROUNDS TO BACK PLATE – THE SHIELD LEADS MUST BE LESS THAN 3.0 INCHES. CONNECT OTHER SHIELD GROUNDS TO AIRCRAFT CHASSIS WITH AS SHORT A CONDUCTOR AS PRACTICAL.

4. AUDIO INHIBIT MAY BE USED TO INHIBIT GTX-345 TIS-B ALERTS DURING IFD FLTA OR TAWS-B AURAL ANNUNCIATIONS. THIS DOES NOT AFFECT THE APPROVAL OF THE TIS-B FUNCTIONS OF THE GTX 345. GTX345 AUDIO INHIBIT MAY BE DRIVEN BY IFD#1 OR IFD#2 IN DUAL IFDXXX/ATLAS INSTALLATIONS. IFD4XX 700-00179-XXX UNITS DO NOT DRIVE AUDIO INHIBIT. IN 700-00179-XXX UNITS SIMULTANEOUS TIS-B AND FLTA AURAL ANNUNCIATIONS ARE POSSIBLE (ADDRESSED IN AFMS).

5. IFD SERIAL PORTS (RS232 AND ARINC 429) OTHER THAN THE ONES SHOWN ABOVE MAY BE SUBSTITUTED WITH APPROPRIATE UNIT SOFTWARE CONFIGURATION.

6. CONFIGURE SELECTED PORTS WITH THE FOLLOWING SETTINGS:

- If the GTX 345 has an internal GPS receiver, the RS 232 position output connection and configuration setup is **not** required
- IFD RS232 output setting: ADS-B+ (G2)... GTX 345 RS 232 input setting: ADS-B+ FMT 2
- IFD RS232 input setting: Capstone HS Wx GTX 345 RS 422 output setting: Optimized Legacy ADS-B
- IFD ARINC429 receive setting: GDL 88 Traffic at High Speed.... GTX 345 ARINC429 transmit setting: Traffic
- Minimum Software Versions Required: IFD v10.2.1 or higher...GTX 345 v2.05 or higher
- With software version 10.2.3.1 using the same RS-232 channel for in/out will not accommodate different baud rates. Use different RS-232 ports for in/out with this software version.

Figure D - 51: GTX 345 Interconnect (con't)

Single IFD to GTX 330 ES

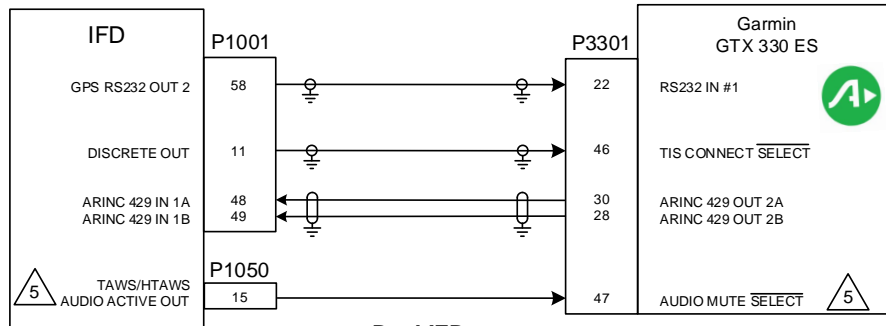

Dual IFD to GTX 330 ES

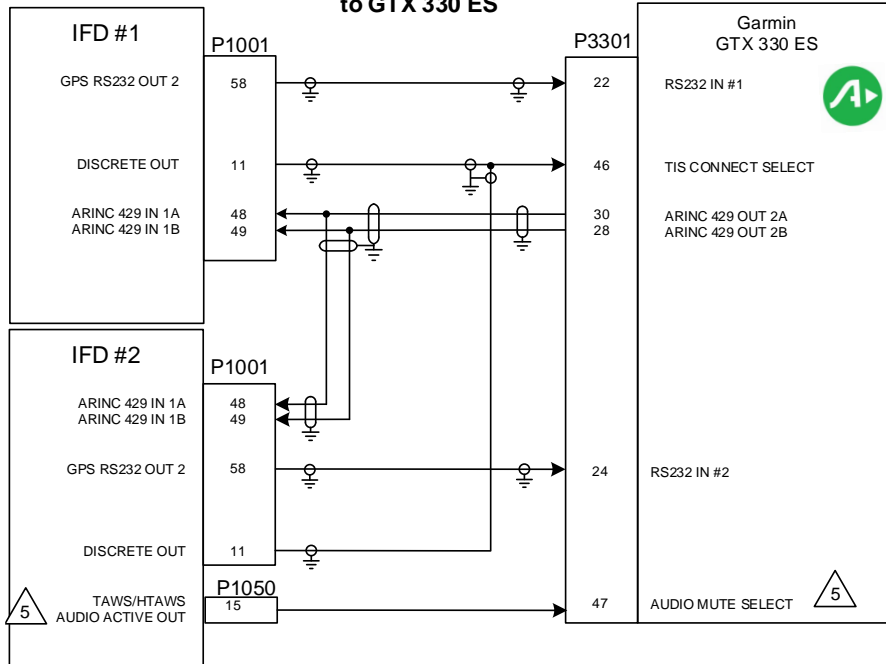

NOTES:

1. ALL WIRES TO BE 24 AWG MINIMUM UNLESS OTHERWISE SPECIFIED.
2. ALL GROUND CONNECTIONS SHOWN FOR THE GTX 330 ES ARE TO BE CONNECTED TO SHIELD BLOCK GROUND.
3. AT IFD UNIT, TERMINATE SHIELD GROUNDS TO THE CONNECTOR BACKSHELL OR USE CARD-EDGE CONNECTOR TO TERMINATE SHIELD GROUNDS TO BACK PLATE – THE SHIELD LEADS MUST BE LESS THAN 3.0 INCHES. CONNECT OTHER SHIELD GROUNDS TO AIRCRAFT CHASSIS WITH AS SHORT A CONDUCTOR AS PRACTICAL.
4. IFD SERIAL PORTS (RS232 AND ARINC 429) OTHER THAN THE ONES SHOWN ABOVE MAY BE SUBSTITUTED WITH APPROPRIATE UNIT SOFTWARE CONFIGURATION.

AUDIO INHIBIT MAY BE USED TO INHIBIT GTX330ES TIS ALERTS DURING IFD4XX/IFD5XX/ATLAS FLTA OR TAWS-B AURAL ANNUNCIATIONS. THIS DOES NOT AFFECT THE APPROVAL OF THE TIS FUNCTIONS OF THE GTX 330ES. AUDIO INHIBIT MAY BE DRIVEN BY IFD#1 OR IFD#2 IN DUAL IFDXX/ATLAS INSTALLATIONS. IFD4XX 700-00179-XXX UNITS DO NOT DRIVE AUDIO INHIBIT. IN IFD4XX 700-00178-XXX UNITS SIMULTANEOUS TIS-B AND FLTA AURAL ANNUNCIATIONS ARE POSSIBLE (ADDRESSED IN AFMS).

6. GTX 330 MUST BE "ES" ENABLED FOR ADS-B OUT FUNCTIONALITY.

Figure D - 52: GTX 330ES Interconnect

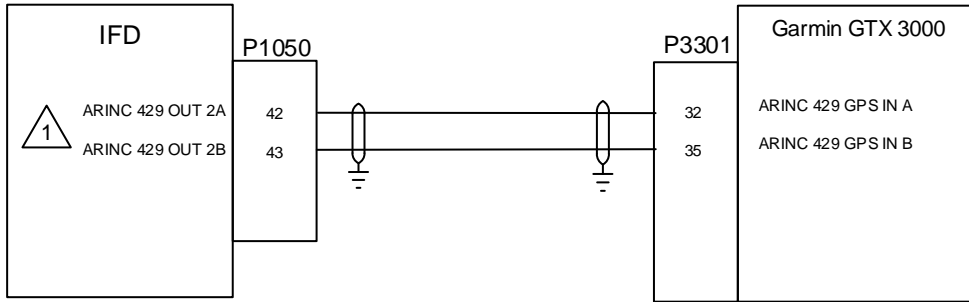

NOTES:

-  CONFIGURE MAIN ARINC 429 OUT 2 TO "ARINC 743A". SET SPEED TO LOW OR HIGH

Figure D - 53: Garmin GTX 3000 Interconnect

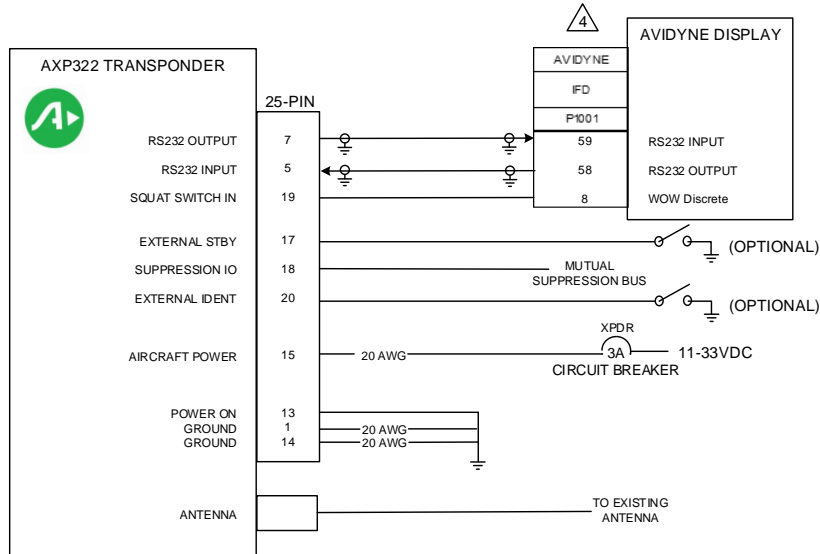

NOTES:

1. ALL WIRES TO BE 22 AWG OR GREATER UNLESS OTHERWISE NOTED.
2. WIRE HARNESS OVERBRAID IS NOT SHOWN BUT MAY BE REQUIRED.
3. REFER TO MANUFACTURER'S DOCUMENTATION FOR COMPLETE PINOUT AND INTERCONNECT INFORMATION.
- ⚠ IF RS-232 PORT 2 IS NOT AVAILABLE, USE ANY OTHER AVAILABLE PORT, USE OF PORT 3 FOR AXP322 SHOULD BE AVOIDED
5. CONFIGURE AXP 322 WOW SELECTION TO AVIDYNE

Figure D - 54: Avidyne AXP322 Interconnect

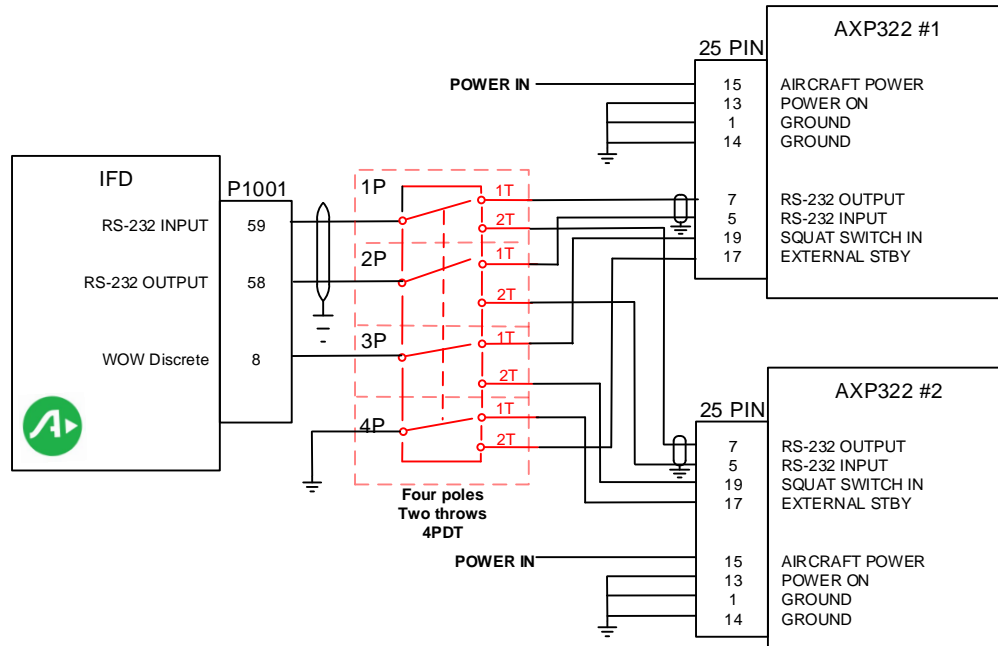

NOTES:

1. ALL WIRES TO BE 22 AWG OR GREATER UNLESS OTHERWISE NOTED.
2. WIRE HARNESS OVERBRAID IS NOT SHOWN BUT MAY BE REQUIRED.
3. REFER TO MANUFACTURER'S DOCUMENTATION FOR COMPLETE PIN-OUT AND INTERCONNECT INFORMATION.
4. IF RS-232 PORT 2 IS NOT AVAILABLE, USE ANY OTHER AVAILABLE PORT. USE OF PORT 3 FOR AXP322 SHOULD BE AVOIDED
5. EACH TRANSPONDER MUST BE CONFIGURED.
6. CONFIGURE AXP322 WOW SELECTION TO AVIDYNE.

Figure D - 55: Avidyne Dual AXP322 Interconnect

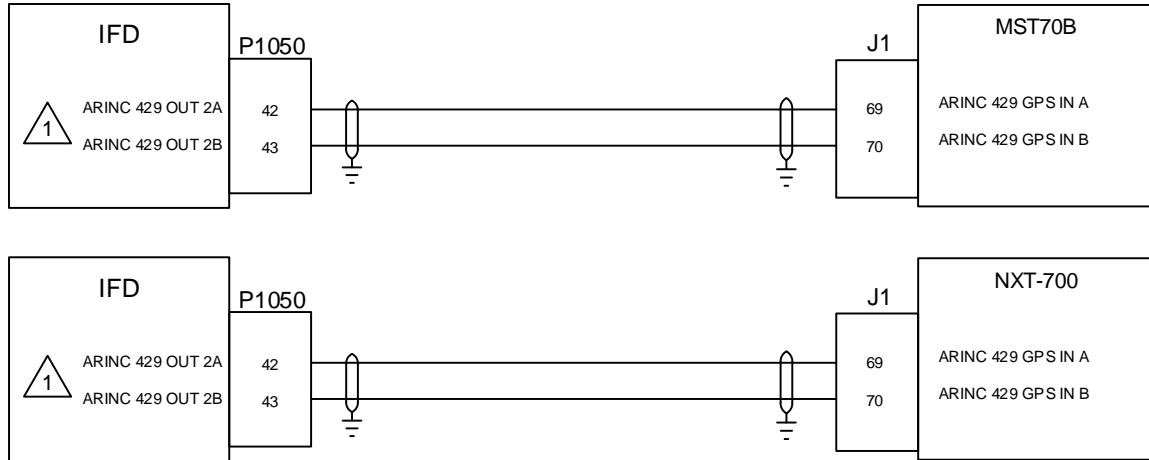

NOTES:

 CONFIGURE MAIN ARINC 429 OUT 2 TO "ARINC 743A". SET SPEED TO LOW OR HIGH

Figure D - 56: NXT 700 MST70B Transponder Interconnect

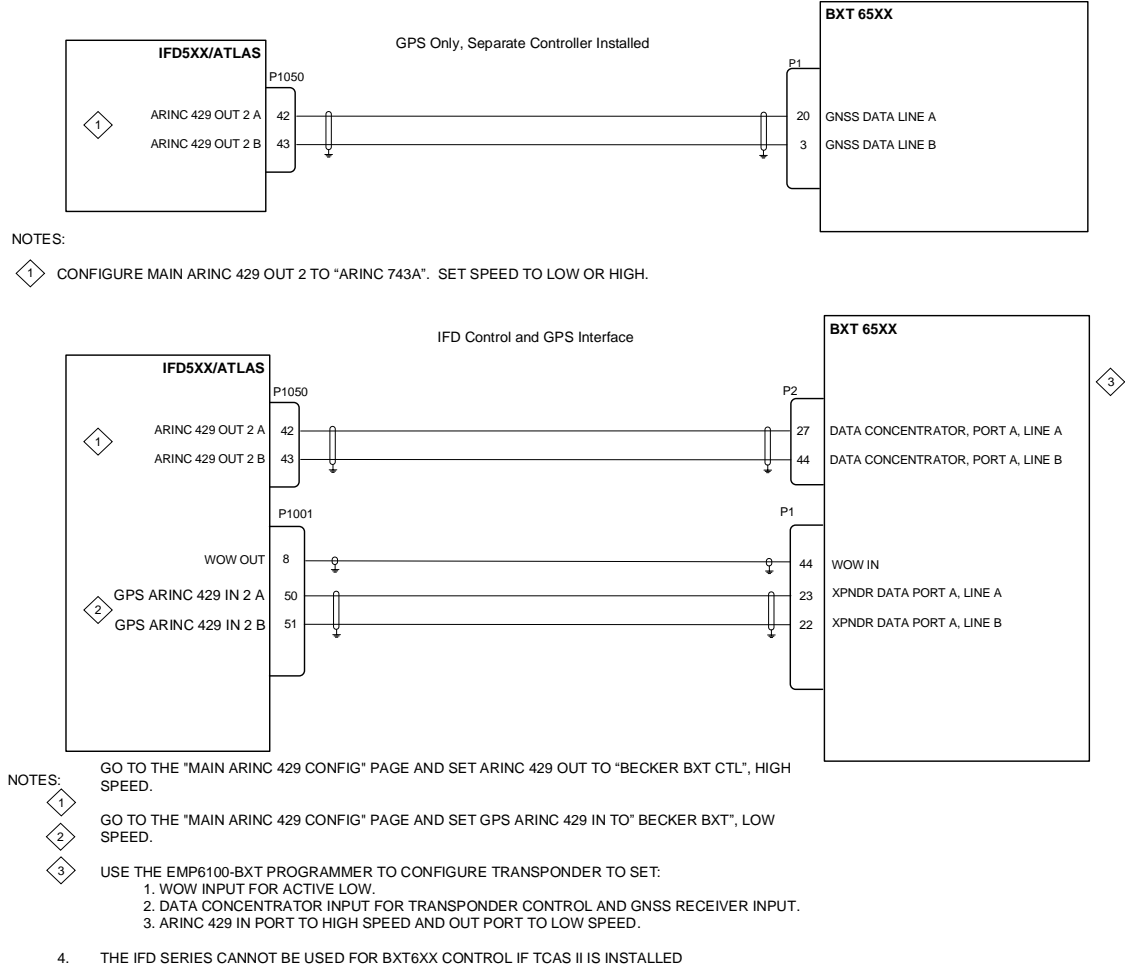
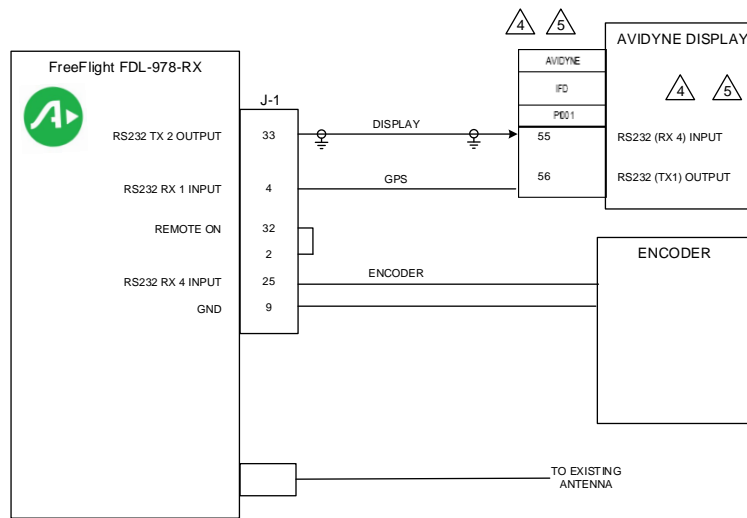

Figure D - 57: Becker BXT 65XX Interconnect



NOTES:

1. ALL WIRES TO BE 22 AWG OR GREATER UNLESS OTHERWISE NOTED.
 2. WIRE HARNESS OVERBRAID IS NOT SHOWN BUT MAY BE REQUIRED.
 3. REFER TO MANUFACTURER'S DOCUMENTATION FOR COMPLETE PINOUT AND INTERCONNECT INFORMATION.
- ⚠ IF RS-232 PORT 2 IS NOT AVAILABLE, USE ANY OTHER AVAILABLE PORT. USE OF PORT 3 FOR CAPSTONE PROTOCOLS SHOULD BE AVOIDED
- ⚠ SET IFD DISPLAY INPUT PORT TO **CAPSTONE TRAFFIC & WX** (38,400 BAUD) , GPS OUTPUT PORT TO **ADS-B+(G2)** (38,400 BAUD).

Figure D - 58: FreeFlight FDL 978RX Interconnect

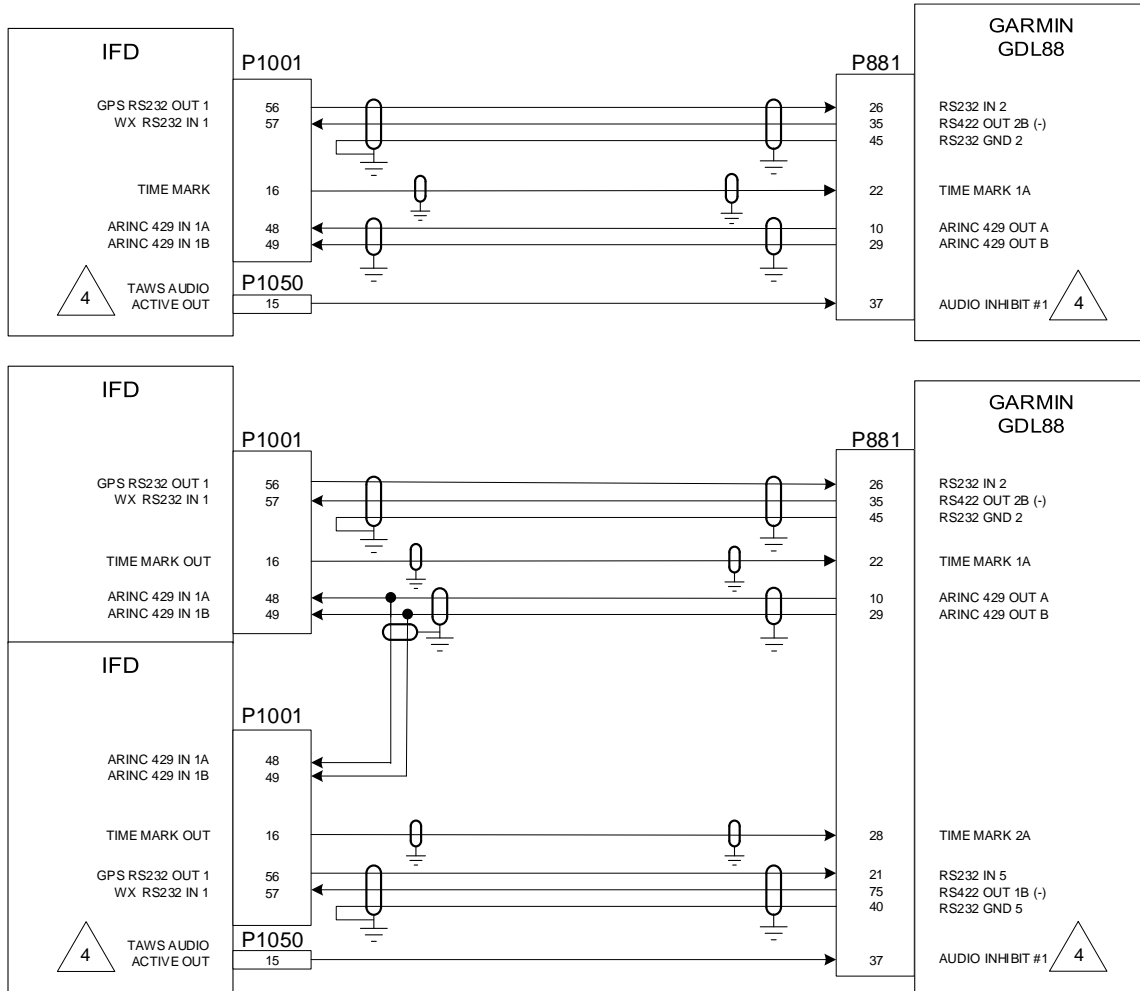

NOTES:

1. ALL WIRES TO BE 24 AWG MINIMUM UNLESS OTHERWISE SPECIFIED.
 2. ALL GROUND CONNECTIONS SHOWN FOR THE GDL88 ARE TO BE CONNECTED TO SHIELD BLOCK GROUND.
 3. AT IFD UNIT, TERMINATE SHIELD GROUNDS TO THE CONNECTOR BACKSHELL OR USE CARD-EDGE CONNECTOR TO TERMINATE SHIELD GROUNDS TO BACK PLATE – THE SHIELD LEADS MUST BE LESS THAN 3.0 INCHES. CONNECT OTHER SHIELD GROUNDS TO AIRCRAFT CHASSIS WITH AS SHORT A CONDUCTOR AS PRACTICLE.
- 4** AUDIO INHIBIT MAY BE USED TO INHIBIT GDL88 ITS-B ALERTS DURING IFD FLTA AURAL ANNUNCIATIONS. THIS DOES NOT AFFECT THE APPROVAL OF THE TIS-B FUNCTIONS OF THE GDL88. GDL88 AUDIO INHIBIT MAY BE DRIVEN BY THE IFD#1 OR IFD#2 IN DUAL IFD INSTALLATIONS. IFD4XX UNITS DO NOT DRIVE AUDIO INHIBIT. IN IFD4XX UNITS SIMULTANEOUS TIS-B AND FLTA AURAL ANNUNCIATIONS ARE POSSIBLE (ADDRESSED IN AFMS).
5. IFD SERIAL PORTS (RS232 AND ARINC 429) OTHER THAN THE ONES SHOWN ABOVE MAY BE SUBSTITUTED WITH APPROPRIATE UNIT SOFTWARE CONFIGURATION.
 6. CONFIGURE SELECTED PORTS WITH THE FOLLOWING SETTINGS;

IFD RS 232 OUTPUT SETTING: ADS-B+ (G2)	GDL88 RS 232 INPUT SETTING: ADS-B FORMAT 2 (NOT REQUIRED IF GDL88 HAS INTERNAL GPS)
IFD RS 232 INPUT SETTING: CAPSTONE HS WX	GDL 88 RS 422 INPUT/OUTPUT SETTING: OPTIMIZED LEGACY ADS-B
IFD ARINC 429 RX SETTING: GDL88 TRAFFIC AT HIGH SPEED	GDL88 ARINC 429 TRANSMIT SETTING: TRAFFIC OUT AT HIGH SPEED
MINIMUM SOFTWARE VERSIONS REQUIRED: IFD XXX V10.2.1 OR HIGHER	GDL88 V3.33 OR HIGHER
 7. THE IFD IS NOT AN APPROVED GPS POSITION SOURCE FOR GDL88 ADS-B OUT FUNCTIONALITY

Figure D - 59: GDL 88 Interconnect

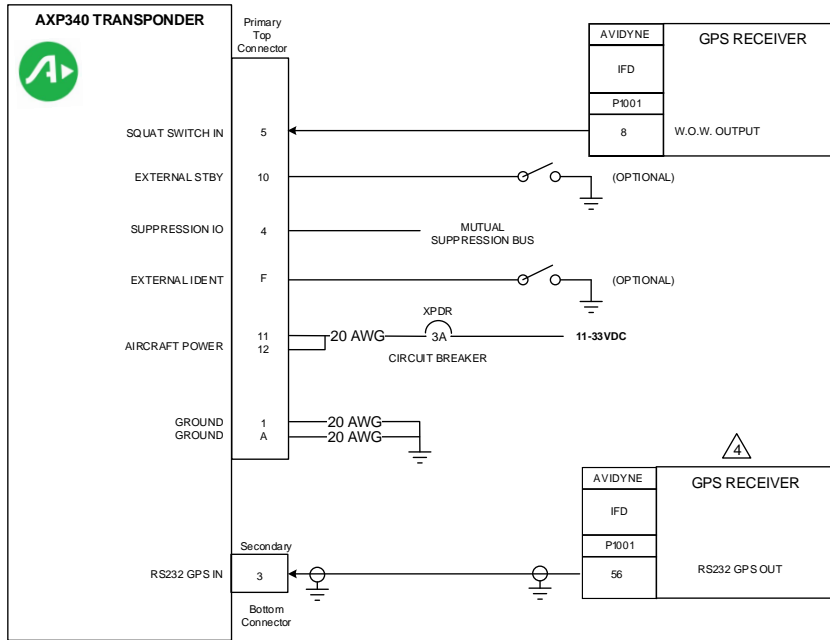

NOTES:

1. ALL WIRES TO BE 24 AWG OR GREATER UNLESS OTHERWISE NOTED.
 2. WIRE HARNESS OVERBRAID IS NOT SHOWN BUT MAY BE REQUIRED.
 3. REFER TO MANUFACTURER'S DOCUMENTATION FOR COMPLETE PINOUT AND INTERCONNECT INFORMATION.
- ⚠️ 4 IF RS-232 PORT 1 IS NOT AVAILABLE, USE ANY OTHER AVAILABLE PORT.

Figure D - 60: Avidyne AXP340 Interconnect

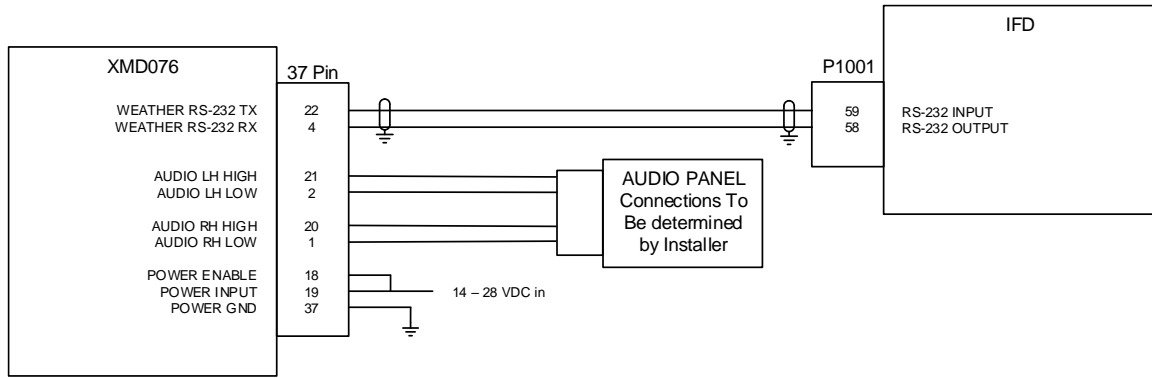

NOTES:

1. ALL WIRES TO BE 22 AWG OR GREATER UNLESS OTHERWISE NOTED.
2. IFD NEEDS SOFTWARE 10.2.3.1 OR HIGHER.
3. IFD WILL NOT CONTROL AUDIO FUNCTIONS.
4. WEATHER DISPLAY IS 115, 200 BAUD.

Figure D - 61: XMD076 Interconnect

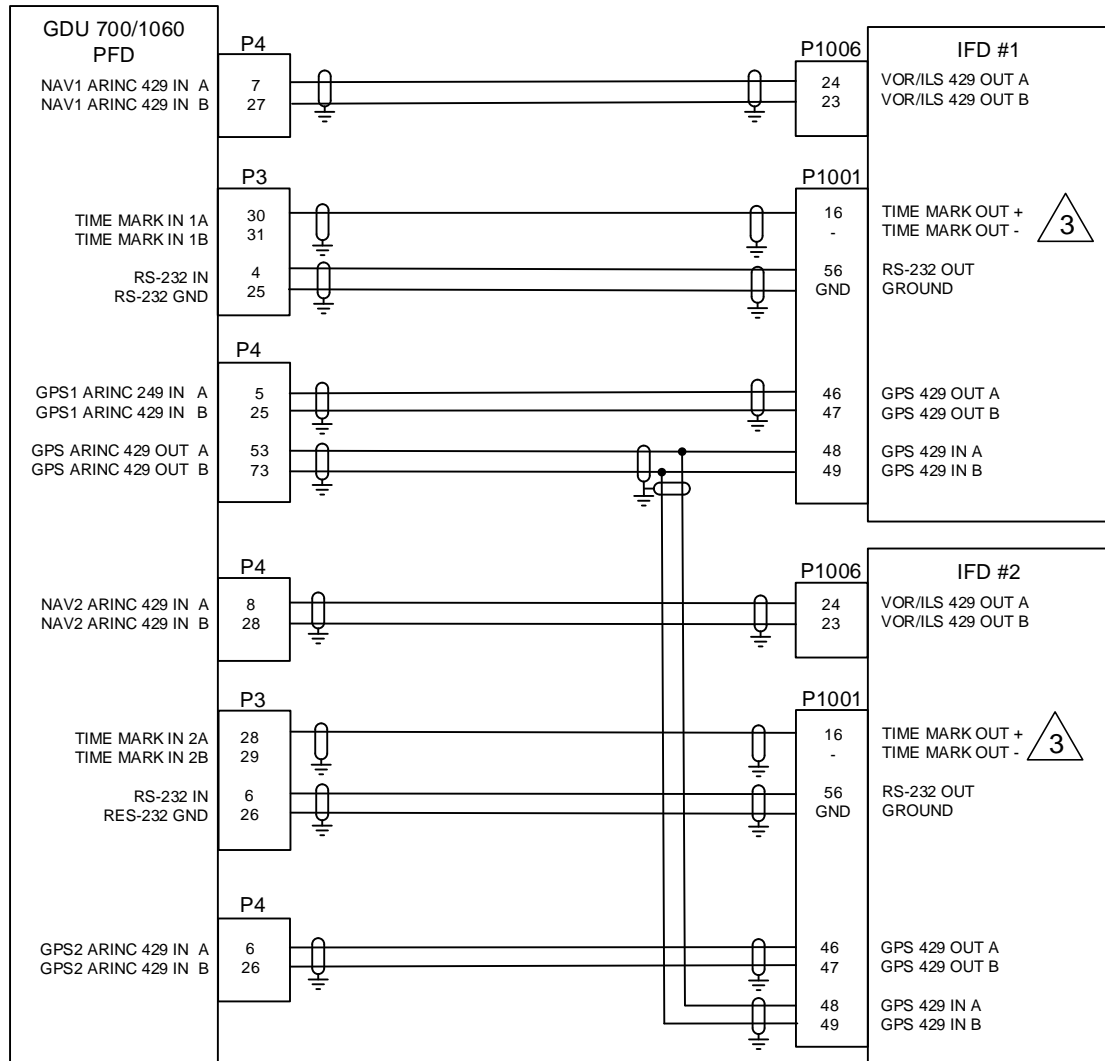

NOTES:

1. ALL WIRES TO BE 22 AWG OR GREATER UNLESS OTHERWISE NOTED.
2. WIRE HARNESS OVERBRAID IS NOT SHOWN BUT MAY BE REQUIRED
3. THE TIME MARK B CONNECTION MUST BE LEFT UNCONNECTED FOR THE INSTALLATION OF IFD UNITS. A SINGLE CONDUCTOR SHIELDED WIRE MAY BE USED FOR THE TIME MARK IN THIS CASE
4. SHOWN ARE CONNECTIONS TO THE IFD, ALL OTHER WIRING IS AT THE DISCRETION OF THE INSTALLER.

Figure D - 62: Single GDU700/1060 PFD Interconnect

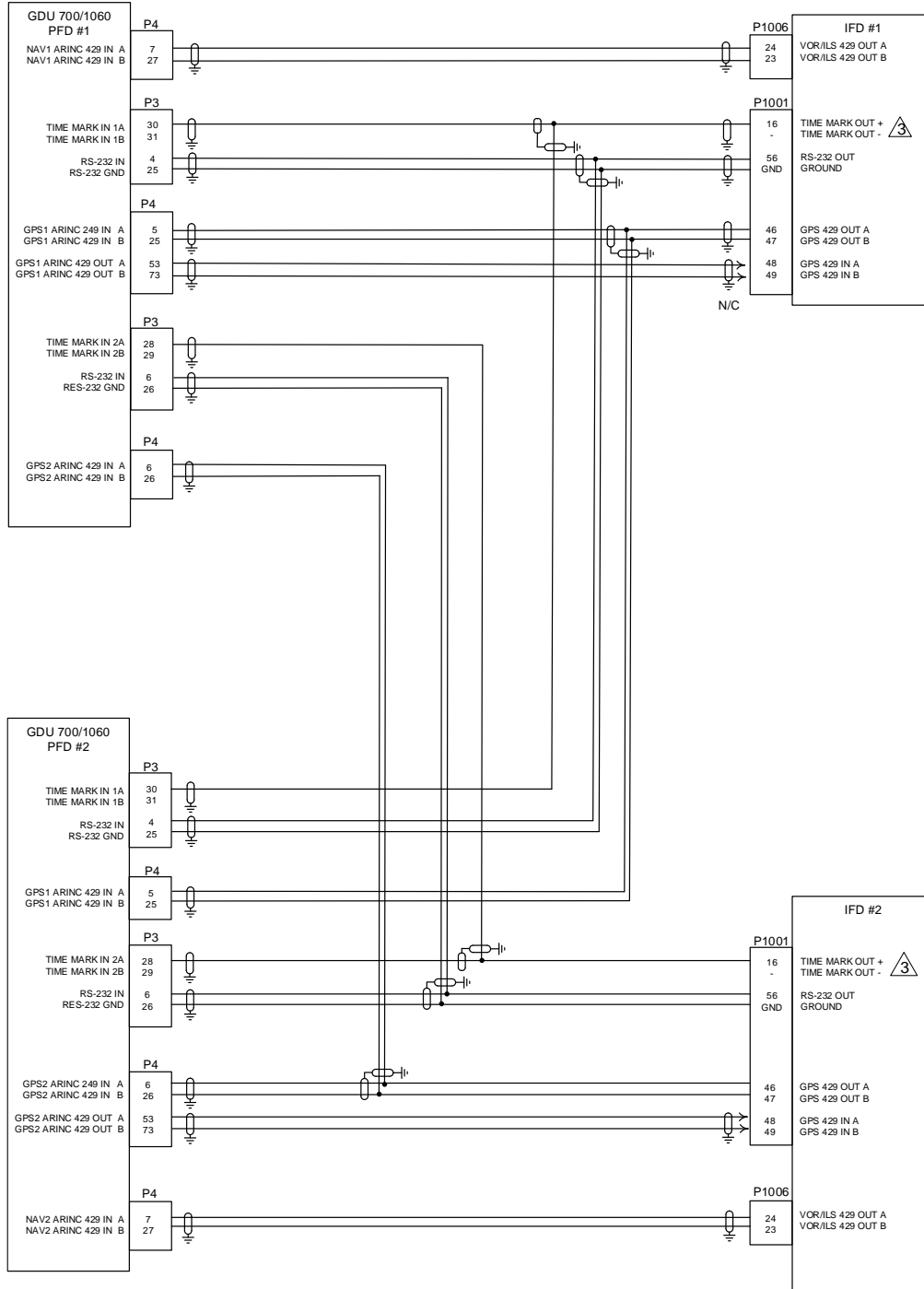

NOTES:

1. ALL WIRES TO BE 22 AWG OR GREATER UNLESS OTHERWISE NOTED.
2. WIRE HARNESS OVERBRAID IS NOT SHOWN BUT MAY BE REQUIRED
3. THE TIME MARK B CONNECTION MUST BE LEFT UNCONNECTED FOR THE INSTALLATION OF IFD SERIES UNITS. A SINGLE CONDUCTOR SHIELDED WIRE MAY BE USED FOR THE TIME MARK IN THIS CASE
4. SHOWN ARE CONNECTIONS TO THE IFD'S, ALL OTHER WIRING IS AT THE DISCRETION OF THE INSTALLER.

Figure D - 63: Dual GDU700/1060 PFD Interconnect

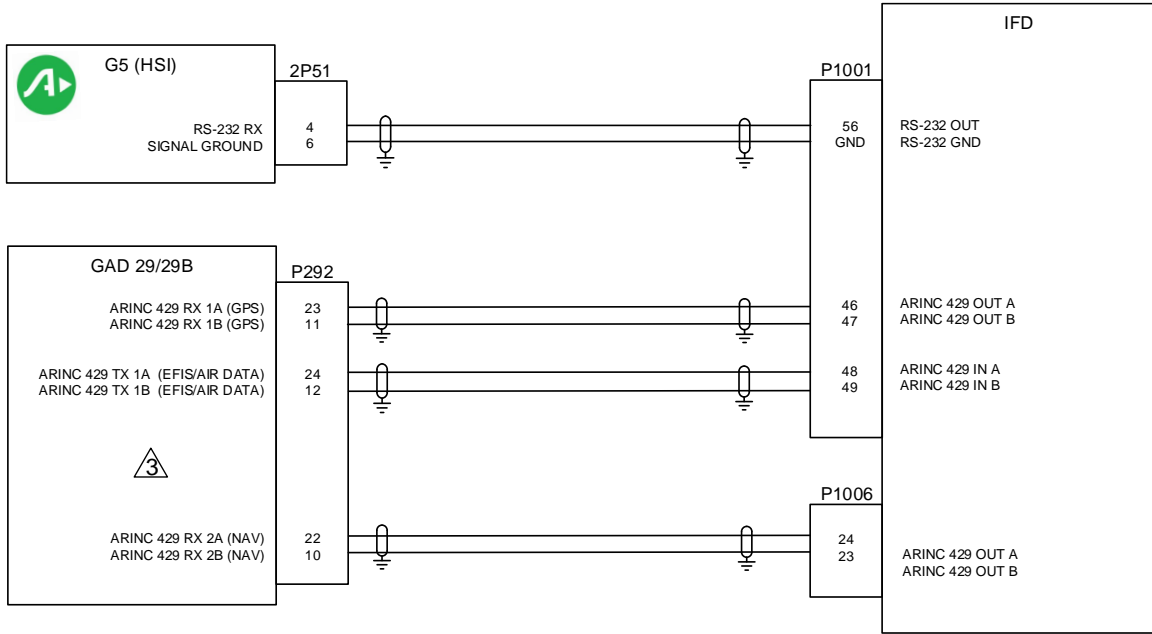

NOTES:

1. ALL WIRES TO BE 22 AWG OR GREATER UNLESS OTHERWISE NOTED.
2. IFD NEEDS SOFTWARE 10.2.3.1 OR HIGHER.



GAD29B INSTALLED WHEN INTERFACING TO A THIRD PARTY AUTOPILOT
SEE GAD29B INTERFACE TO THIRD PARTY AUTOPILOT INTERCONNECT
DIAGRAMS FOR FURTHER INFORMATION.

IFD Config Page	Config Option	Configuration Setting
MAIN ARINC 429 CONFIG Page	IN (x)	Speed = Low EFIS/AirData (Garmin Autopilot, No Autopilot) GAD42 (Analog Autopilots Only)
	OUT	Speed = Low Data = GAMA 429
	VNAV	ENABLED
MAIN RS-232 CONFIG Page		Input = OFF Output = MapMX (WAAS GPS) AVIATION (non WAAS GPS)
VOR/LOC/GS ARINC 429 CONFIG Page		RX = Low TX = Low VOR/ILS 1

Figure D - 64: Garmin G5 EHSI Interconnect

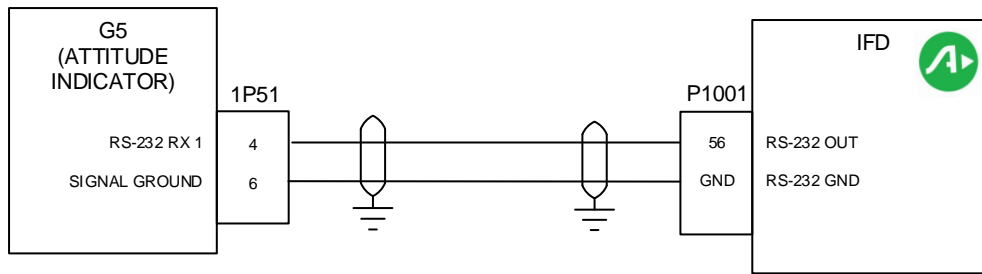

NOTES:

1. ALL WIRES TO BE 22 AWG OR GREATER UNLESS OTHERWISE NOTED.
2. WIRE HARNESS OVERBRAID IS NOT SHOWN BUT MAY BE REQUIRED.

IFD Config Page	Configuration Setting
MAIN RS-232 CONFIG PAGE	Input = OFF Output = MapMX (WAAS GPS) AVIATION (non WAAS GPS)

Figure D - 65: Garmin G5 EADI Interconnect

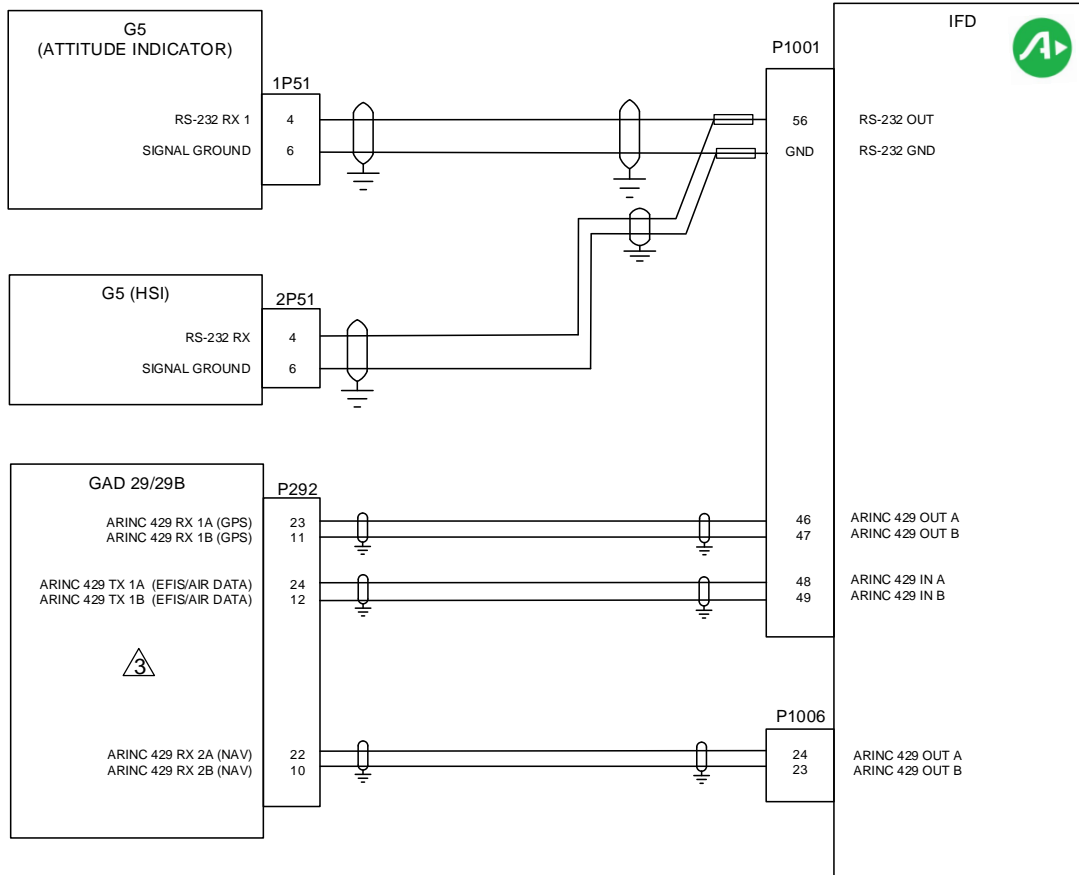

NOTES:

1. ALL WIRES TO BE 22 AWG OR GREATER UNLESS OTHERWISE NOTED.
2. IFD NEEDS SOFTWARE 10.2.3.1 OR HIGHER.



GAD29B INSTALLED WHEN INTERFACING TO A THIRD PARTY AUTOPILOT
SEE GAD29B INTERFACE TO THIRD PARTY AUTOPILOT INTERCONNECT
DIAGRAMS FOR FURTHER INFORMATION.

IFD Config Page	Config Option	Configuration Setting
MAIN ARINC 429 CONFIG Page	IN	Speed = Low EFIS/AirData (Garmin Autopilot, No Autopilot) GAD42 (Analog Autopilot Only)
	OUT	Speed = Low Data = GAMA 429
	VNAV	ENABLED
MAIN RS-232 CONFIG Page		Input = OFF Output = MapMX (WAAS GPS) Aviation (Non WAAS GPS)
VOR/LOC/GS ARINC 429 CONFIG Page	SPEED	RX = Low TX = Low
	SDI	VOR/ILS 1

Figure D - 66: Garmin G5 EFIS Interconnect

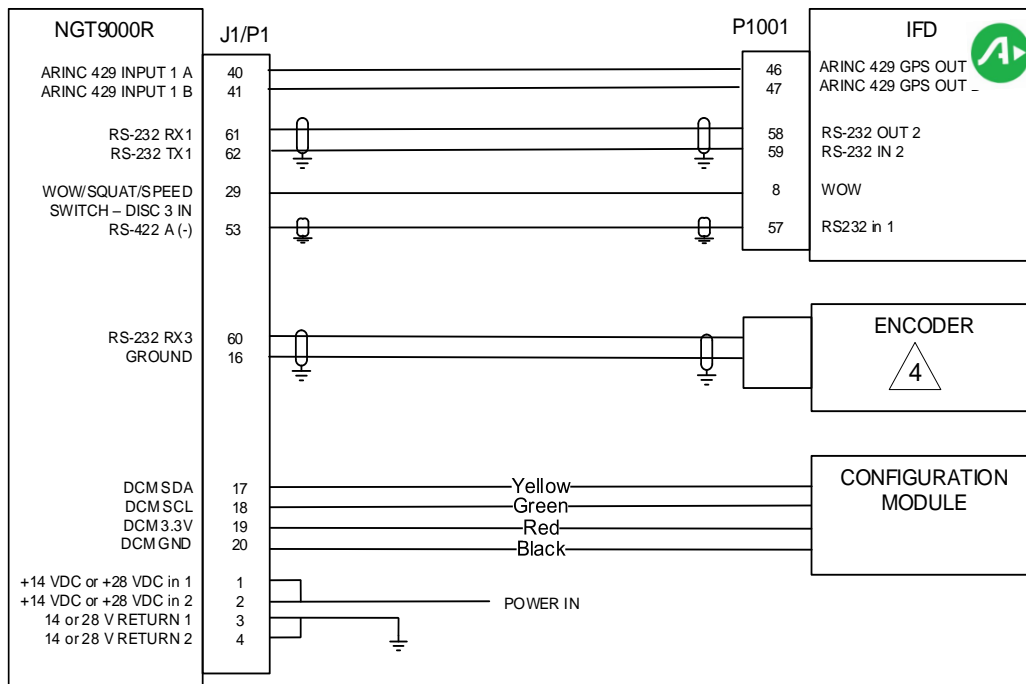

NOTES:

1. ALL WIRES TO BE 22 AWG OR GREATER UNLESS OTHERWISE NOTED.
 2. WIRE HARNESS OVERBRAID IS NOT SHOWN BUT MAY BE REQUIRED
 3. CONFIGURE NGT9000R WOW INPUT TO OPEN IN AIR.
 4. REFER TO THE INSTALLATION MANUAL OF THE ALTITUDE ENCODER FOR PINOUT AND FORMAT SETTINGS.
 5. CONFIGURE NGT9000R RS-232 OUT BAUD TO 115,200.*
 6. CONFIGURE IFD RS-232 INPUT TO CAPSTONE HS TFC&WX
 7. CONFIGURE THE IFD RS-232 OUTPUT/INPUT TO NGT9000R*
- * See Lynx NGT-9000 Installation Manual P/N 0040-17001-01
8. CONFIGURE OPTIONAL IFD GPS ARINC 429 OUTPUT TO ARINC 743A. PORT SPEEDS MUST MATCH

Figure D - 67: NGT9000R Interconnect

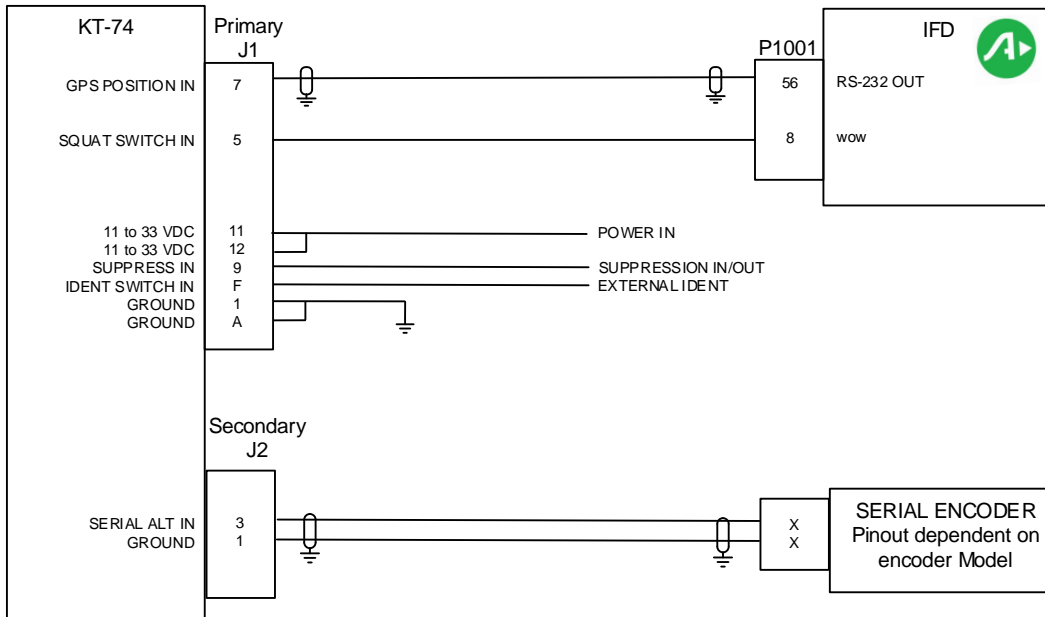

NOTES:

1. ALL WIRES TO BE 22 AWG OR GREATER UNLESS OTHERWISE NOTED.
2. WIRE HARNESS OVERBRAID IS NOT SHOWN BUT MAY BE REQUIRED.
3. SET SQUAT SWITCH SETTING TO LOW WHEN GROUND.
4. SET GPS POSITION SOURCE TO TRIG ADS-B AT 9600 BPS.
5. SET GPS CERTIFICATION TO LEVEL C.
6. SET GPS NACv TO 1 OR < 10m/SECOND.
7. SET THE IFDXXX/ATLAS OUTPUT TO ADS-B (AVI).
8. PARALLEL ALTITUDE WIRING, NOT SHOWN, CAN BE USED IN PLACE OF SERIAL ALTITUDE.

Figure D - 68: KT-74 Interconnect

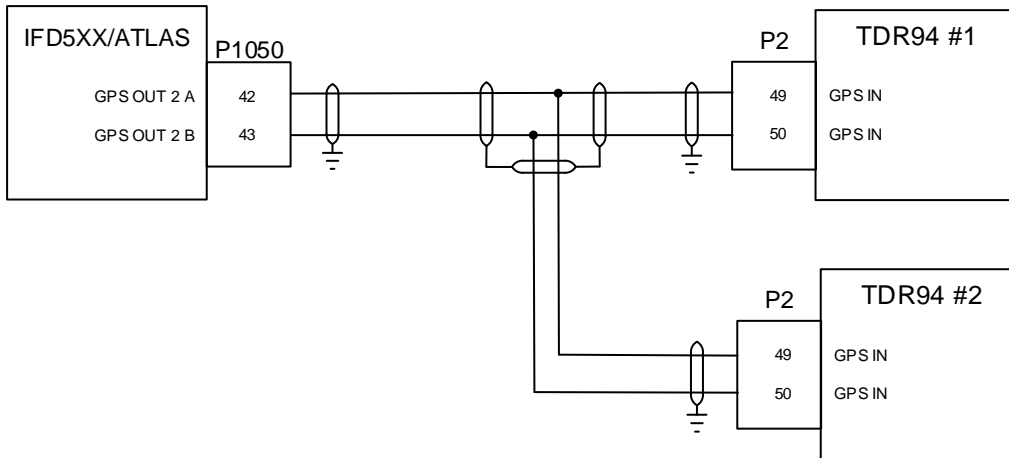

NOTES:

1. ALL WIRES TO BE 22 AWG MINIMUM UNLESS OTHERWISE SPECIFIED.
2. WIRE HARNESS OVERBRAID IS NOT SHOWN BUT MAY BE REQUIRED .
3. CONFIGURE IFDXXX/ATLAS ARINC 2 OUT TO HIGH SPEED, ARINC 743A. VERIFY THAT THE TDR94 PORT SPEED IS SET TO HIGH SPEED
4. SHOWN IS THE CONNECTIONS TO THE IFD. ALL OTHER WIRING IS AT THE DISCRETION OF THE INSTALLER.

Figure D - 69: TDR-94 Interconnect

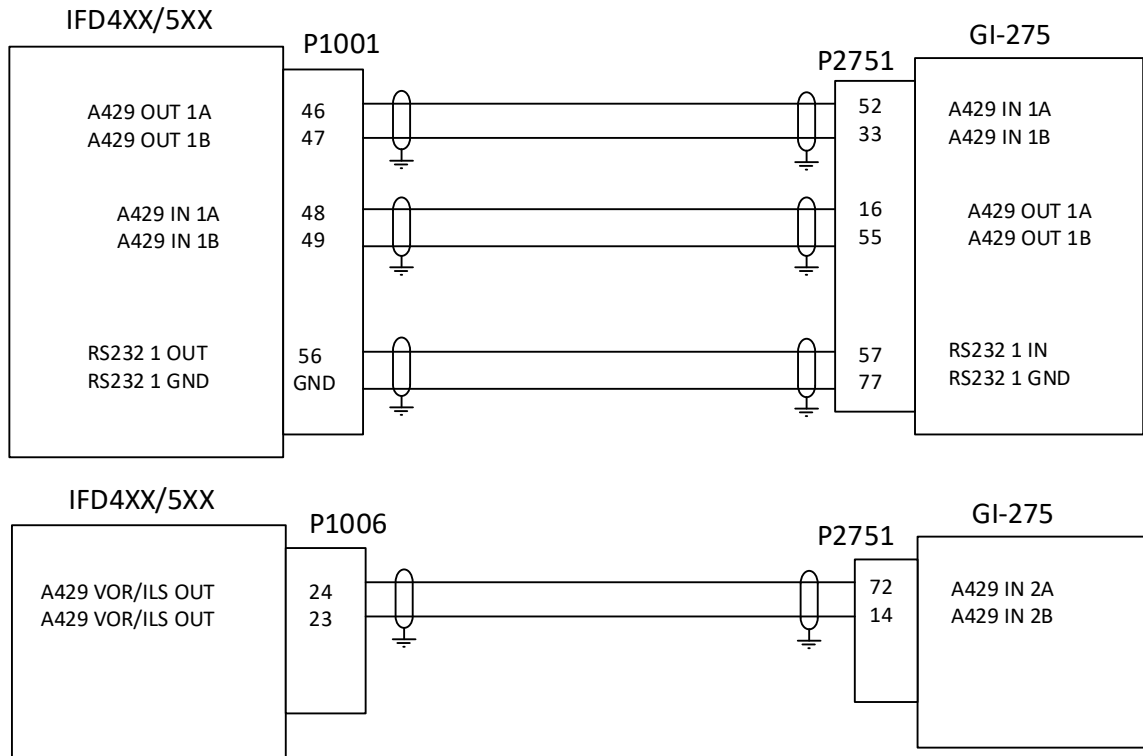

Notes:

1. IFD CONFIGURATIONS:

- | | |
|--------------------------|---------------------------------------|
| a. IFD GPS ARINC429 OUT: | GAMA429 |
| b. IFD GPS ARINC429 IN: | GARMIN GDU |
| c. IFD GPS SDI: | LNAV1 for IFD#1; LNAV2 for IFD#2 |
| d. IFD VNAV: | Enable Labels |
| e. IFD VOR/ILS 429 OUT: | VHF 429 |
| f. IFD VOR/ILS SDI: | VOR/ILS1 or IFD#1; VOR/ILS2 for IFD#2 |

Figure D - 70: Garmin GI-275 Interconnect

Appendix E: Troubleshooting Guide

Component	Trouble	Probable Cause	Solution
IFD5XX IFD4XX ATLAS	The unit is not getting power to the main connector	The unit is not getting power.	Check Circuit Breaker
			Check wiring and unit seating in tray
	The IFD is not computing a position	Wiring	Check Coaxial Cables
		Antenna	Verify antenna has a clear unobstructed view of the sky
	The GPS Signal levels are very low	Wiring	Check coaxial cable and connectors
			Check routing
		Antenna shading	Verify the antenna is mounted on top of the aircraft
			Verify antenna is clear of hangars, buildings, etc.
	VHF Com is not transmitting (NOT APPLICABLE FOR IFD410/510/545 OR ATLAS FMS ONLY UNITS)	Wiring	Check the aircraft's PTT switch
			Check Audio Panel (if installed)
			Check wiring
	The IFD5XX/4XX is not tuning the DME (NOT APPLICABLE FOR IFD410/510/545 OR ATLAS FMS ONLY UNITS)	Configuration	Verify the IFD5XX/4XX is configured correctly.
		Wiring	Checking wiring
		DME	Verify the DME is configured for the IFD5XX/4XX tuning type
	RS-232 Device is not communicating	Configuration	Verify the IFD5XX/4XX is configured for the appropriate device.
		Wiring	Check wiring and unit seating in tray
	ARINC 429 is not communicating	Configuration	Verify the IFD5XX/4XX is configured for the appropriate device.
		Wiring	Check wiring and unit seating in tray

Component	Trouble	Probable Cause	Solution
IFD5XX IFD4XX ATLAS	Display appears excessively dim or off	Configuration (configured for "night mode")	Check cockpit dimming rheostat position
			Check Flight Mode settings on User Options page for Display and Bezel Brightness and source
			Check power button on IFD
			Check Mx Mode settings on Lighting page for proper setting
	CMOS Battery Dead CAS Message	The 10-year life expectancy of the CMOS battery has been reached. This may result in longer GPS satellite acquisition times.	Return the IFD to Avidyne Service Center for battery replacement
	VHF Radio Slots displaying Red-Xs (NOT APPLICABLE FOR IFD410/510/545 OR ATLAS FMS ONLY UNITS)	No power on the P1002 Connector	Ensure all governing circuit breakers have power
		Chassis ID not set to 0 or 1	Check and set as required the Chassis ID per section 7.3
	Unit starts up in Maintenance Mode	USB fob installed at power up	Ensure fob is not in the USB slot and reapply power to the IFD
		IFD last shut down in Maintenance Mode	Press the left or right side of the AUX page until the "DONE" Line Select Key is visible and press that LSK to force the IFD to restart into flight mode
	Unable to get out of Maintenance Mode or not sure how to		Press the left or right side of the AUX page until the "DONE" Line Select Key is visible and press that LSK to force the IFD to restart into flight mode
	IFD to IFD Communication is not functional as indicated by either "CROSSYNC FAIL" CAS message or no data sharing observed between the IFDs	IFD is misconfigured	Ensure RS-232 Channel 3 is set to CrossSync on each IFD
		Wiring incorrect	Ensure serial Channel 3 wiring is installed per Section 4.7
	"Config Mismatch" CAS message on IFD5XX/4XX (dual IFD5XX/4XX/ATLAS only)	Configuration mismatch between the two IFD units	Power cycle the IFD units Verify configuration on IFD5XX/4XX units If problem persists, send IFD5XX/4XX log data to Avidyne Technical Support

Component	Trouble	Probable Cause	Solution
	"No Comm with <x>" where <x> is an attached device	Device is not wired correctly or RS232 or ARINC429 connection is on a port other than what is configed in Maintanace mode	Confirm device is powered Check wiring Confirm wired port matches configured port

Appendix F: Configuration Setup

In order to support the requirements of some validations of the AML STC, this section should be easily removable and inserted into the aircraft logs.

For those installations where an IFD is replacing a GNS-530/W or GNS-430, please record the following parameters from the GNS-530/W or GNS-430/W setup pages before removing the unit (*Note: this will need to be conducted for each GNS-530/W or GNS-430/W being replaced*):

WAAS Enabled (530W or 430W with approved antenna)? Yes No 2nd unit: Yes No
 N/A

530/W or 430/W Hardware Part Number and Revision Number (back of unit or aircraft logs) _____/_____

530/W or 430/W Software Part Number ("Main SW Version" on start up splash screen) __-_____/_____

If multiple GNS-530/W or GNS-430/W were installed, describe the slot/location that this specific unit was removed from.

Cockpit Location of Unit(s) in Question

Description of location/slot in the cockpit (Include rough sketch if deemed helpful)	
--	--

Measure the distance from the ground to the top of the GPS antenna to nearest tenth of a foot, as shown in the image below, and enter the value in the box below: (to the nearest 1/10th foot).

Measured Height of GPS Antenna

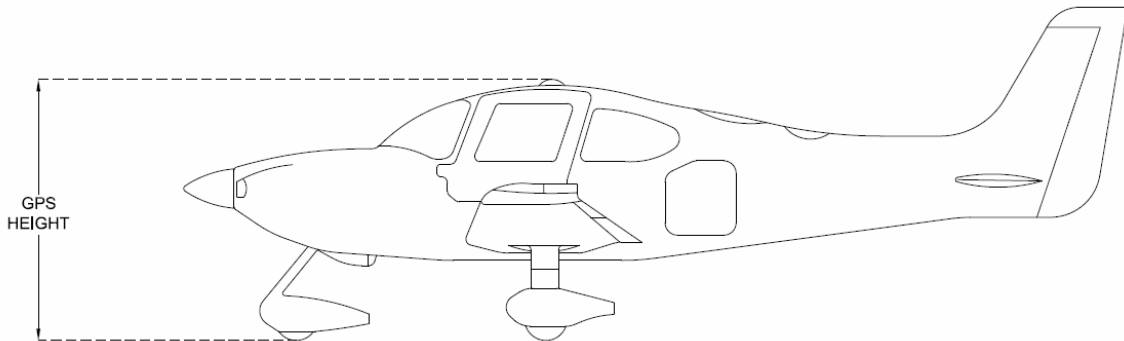

Please list the other avionics that are installed in the aircraft (please be as specific as possible with make and models of the gear) and connected to the GNS-530/W or GNS-430/W. Enter "None" or "Don't Know" as required. The GNS-530/W or GNS-430/W Setup pages will be captured on subsequent pages.

Identification of Devices Connected to the GNS-530/W or GNS-430/W

	1 st GNS 530/W or GNS 430/W	2 nd GNS 530/W or GNS-430/W (if applicable)
Traffic		
Datalink		
Lightning Sensor		
Autopilot		
Fuel Flow System		
Display(s)		
CDI(s)		
RMI(s)		
Transponder		
DME		
ADF		
Air Data		
IRU/INS		
Other		
Other		
Other		

Please list the other avionics that are installed in the aircraft and connected to the IFD. Enter "None" or "Don't Know" as required. The IFD Setup pages will be captured on subsequent pages.

Identification of Devices Connected to the IFD at time of Install

	1 st IFD	2 nd IFD (if applicable)
Traffic		
Datalink		
Lightning Sensor		
Autopilot		
Fuel Flow System		
Display(s)		
CDI(s)		
RMI(s)		

Transponder		
DME		
ADF		
Air Data		
IRU/INS		
Other		
Other		
Other		

GNS-530/W or GNS-430/W Maintenance Mode Entry:

GNS-530 configuration data is accessed from the GNS-530/W Maintenance Mode settings which are entered via holding ENTR button on 530/W bezel during power application.

GNS-530/W or GNS-430/W Page Navigation:

Use the inner right knob on the GNS-530/W to scroll through the maintenance mode pages. Each clockwise click of the knob selects the next page. On pages where selectable fields exist, a push of the right knob will produce a flashing cursor. The outer right knob moves through the fields on a page when there is a flashing cursor. Twist the inner right knob clockwise to see a list of choices. Use the inner right knob to scroll through the list of choices and press the "ENT" button to select the desired choice.

IFD Maintenance Mode Entry:

IFD configuration data is accessed via Mx Mode which is entered by starting the IFD with a USB Fob already installed or selecting the AUX page, SYS tab, ensuring that the "Select" LSK = Software, and then pressing the "Download Logs" LSK, followed by the "Confirm" LSK. These tables contain all the data that can be entered at time of installation to ensure the IFD is properly configured. There are additional setup options that selectable by the pilot (Display Options on AUX Setup tab) that are not documented here.

IFD Page Navigation:

To reach the IFD pages on which this data is to be entered, select the CONFIG tab in Maintenance Mode. Use the outer right knob to select the page - each clockwise click of the outer right knob selects the next page in the list. Push the right knob in to generate a cursor and then use the outer right knob to select an individual field with the cursor. Then twist the inner right knob to scroll through the selectable options for that field and push in the right knob when done with each field selection.

For retrofit installations (those installations in which an IFD is replacing a GNS-530/W or GNS-430/W), enter the data in the following tables/menu pages from the corresponding fields recorded below in the GNS-530/W or GNS-430/W tables on the left side of each page. Repeat for each retrofit IFD.

For new installations (those installations in which an IFD is NOT replacing a GNS-530/W or GNS-430/W), select and record the appropriate settings for each configuration page per the descriptive material below each table.

Garmin 530/W or 430/W - MAIN ARINC 429 CONFIG page

	<i>Speed</i>	<i>Data</i>
<i>IN 1</i>		
<i>IN 2</i>		
<i>OUT</i>		
<i>SDI</i>		
<i>VNAV (if present)</i>		

IFD - Main ARINC 429 Config Page (1/12)

	<i>Speed</i>	<i>Data</i>
<i>In 1</i>		
<i>In 2</i>		
<i>Out</i>		
<i>SDI</i>		
<i>VNAV</i>		

For new IFD5XX/ATLAS installations, see Section 7.5 for selections and descriptions

GNS-530/W or 430/W – MAIN RS232 CONFIG Page

	<i>Input</i>	<i>Output</i>
<i>CHNL 1</i>		
<i>CHNL 2</i>		
<i>CHNL 3</i>		
<i>CHNL 4</i>		
<i>CHNL 5</i>		

IFD - Main RS232 Config Page (2/12)

<i>CHNL 3</i>		
<i>CHNL 4</i>		
<i>CHNL 5</i>		
<i>CHNL 6</i>		

For new IFD5XX/ATLAS Installations, see Section 7.5.4 for selections and descriptions. IFD4XX do not have Channels 5 and 6.

	<i>Input</i>	<i>Output</i>
<i>CHNL 1</i>		
<i>CHNL 2</i>		

**GNS-530/W or 430/W – MAIN SYSTEM CONFIG
Page (Fuel)**

CONFIGURE	<i>Fuel</i>
FUEL TYPE	

IFD—Main System Config Page (3/12)

Tail Number is a free text field and is used for JSUM and Paid Options

**GNS-530/W or 430/W – MAIN SYSTEM CONFIG
Page (Terrain) [if present]**

CONFIGURE	<i>Terrain</i>
TERRAIN TYPE	
TEST CARD?	
HW CONFIG	
012-00296-	
012-00401-	

<i>Fuel Type</i>	
<i>GPS Select</i>	
<i>Airframe</i>	
<i>Tail Number</i>	
<i>External TAWS</i>	
<i>WOW Input (Helo)</i>	
<i>Checklists</i>	
<i>TIS-B Annunciation</i>	
<i>Joystick Input</i>	
<i>Appr Roll Steer</i>	
<i>Nav Radio Active</i>	

**GNS-530/W or 430/W– MAIN SYSTEM CONFIG
Page (Discrettes) [if present]**

CONFIGURE	<i>Discrettes</i>
GPS SELECT	
COM PRESETS	

Note: Com Presets are always enabled on the IFD

**GNS-530/W or 430/W– MAIN SYSTEM CONFIG
Page (Airframe) [if present]**

CONFIGURE	<i>Airframe</i>
AIRFRAME	
AIR/GROUND (if present)	

Note: The Air/Ground selection is only present when helicopter is selected for the airframe and is a trigger to look for squat switch input. No equivalent in IFD.

GNS-530/W or 430/W – MAIN INPUTS Page

OAT		HDG		B ALT	
SAT		W DIR		D ALT	
TAT		GPS SC		P ALT	
IAS		VLC SC		L FF	
TAS		CDI		R FF	
W SPD				T FF	
				T FOB	
JOYSTICK WPT					

IFD – MAIN INPUTS Page (4/12)

OAT		HDG		B ALT	
SAT		W DIR		D ALT	
TAT		GPS SC		P ALT	
IAS		VLC SC		L FF	
TAS		CDI		R FF	
W SPD				T FF	
				T FOB	
JOYSTICK WPT					

Note: There is no data to enter on the IFD from this page – it is for diagnostics only

GNS-530/W or 430/W – INSTRUMENT PANEL
SELF TEST (For reference only)

CDI		FUEL CAPACITY
FLG		
VCDI		FUEL ON- BOARD
VFLG		
TO/FRM		FUEL FLOW
ANNUN		
RMI		Set Fuel Flow?
OBS		
DTK		

No IFD Equivalent Page

GNS-530/W or 430/W- MAIN LIGHTING Page

	Display		Key	
LIGHTING				
SOURCE				
RESP TIME / MIN				
SLOPE / OFFSET				
PHOTO TRANS % (if applicable)				
PHOTO SLP / OFST (if applicable)				

IFD – MAIN LIGHTING Page (5/12)

	Bezel	Display	
Photo Response Time			
Photo Slope			
Photo Minimum			
Photo Maximum			
dimBus Transition %			
dimBus Slope			
dimBus Minimum			
dimBus Maximum			
dimBus Curve			
Current Lighting	Dimming Bus	Calibration	
Bezel	dimBus Type		
Display	dimBus Max Voltage		
Mx Input	dimBus Min Voltage		

See Section 7.5.7 for instructions on this page.

GNS-530/W or 430/W – DATE / TIME SETUP
 Page (No Need to Fill In – For Reference Only)

UTC DATE	UTC TIME

No IFD5XX/4XX/ATLAS Equivalent Page

GNS-530/W or 430/W – MAIN DISCRETE I/O Page

GRAY CODE	EXTERNAL SWITCH STATE	DECODED ALTITUDE	
	EXTERNAL SWITCH STATE		
	RMT CDI <input type="checkbox"/>	OBS <input type="checkbox"/>	
DISCRETE TOGGLE			
APR <input type="checkbox"/>	OBS <input type="checkbox"/>	ILS/GPS APR <input type="checkbox"/>	
GPS <input type="checkbox"/>	TERM <input type="checkbox"/>		
INTEG <input type="checkbox"/>	VLOC <input type="checkbox"/>		
MSG <input type="checkbox"/>	WPT <input type="checkbox"/>		

Note: Check off the squares, as required, to match the solid squares on the GNS-530/430 unit - these check that discretes are wired correctly.

IFD – MAIN DISCRETE I/O Page (6/12)

GRAY CODE		DECODED ALTITUDE	
EXTERNAL SWITCH STATE			
RMT CDI <input type="checkbox"/>	RMT OBS <input type="checkbox"/>	RMT RCL <input type="checkbox"/>	
TER INHB <input type="checkbox"/>	AUD INHB <input type="checkbox"/>		
DISCRETE TOGGLES			
APR <input type="checkbox"/>	OBS <input type="checkbox"/>	ILS/GPS APR <input type="checkbox"/>	
GPS <input type="checkbox"/>	TERM <input type="checkbox"/>	GPS SELECT <input type="checkbox"/>	
INTEG <input type="checkbox"/>	VLOC <input type="checkbox"/>	TER CAUT <input type="checkbox"/>	
MSG <input type="checkbox"/>	WPT <input type="checkbox"/>	TER INHB <input type="checkbox"/>	
		TER N/A <input type="checkbox"/>	
		TER WARN <input type="checkbox"/>	

Note; ON or OFF will be Displayed

GNS-530/W or 430/W – MAIN CDI / OBS CONFIG Page

	CDI	NAV FLAG	TO-FROM
LAT			
VERT			
SELECTED COURSE			
CDI	OBI SOURCE	V-FLAG STATE	

IFD – MAIN CDI / OBS CONFIG Page (7/12)

	CDI	NAV FLAG	TO-FROM
LAT			
VERT			
SELECTED COURSE			
	Ignore SEL CRS for GPS		
	Ignore SEL CRS for VLOC		
CDI	OBI SOURCE	V-FLAG STATE	

For new IFD installations, see Section 7.5.9 for selections and descriptions.

GNS-530/W or 430/W – COM SETUP Page (GNS-530W/430W Only)

FREQ		SQ 250	
SPACING		SQ 833	
		SIDETN	
		MIC	
STORE CALIBRATION?			
PTT	<input type="checkbox"/>	XFR	<input type="checkbox"/> <input type="checkbox"/> TX <input type="checkbox"/>

Note: The squares above do not need to be recorded - they fill in when/if that function is activated.

No IFD Equivalent Page

(Use the User Options tab to select 25 or 8.33 kHz spacing)

GNS-530/W or 430/W – VOR/LOC/GS CDI Page

	CDI	NAV FLAG	SPR FLAG	TO-FROM
LAT				
VERT				
SELECTED COURSE				
DME CHANNEL MODE				

GNS-530W or GNS-430W Only

IFD – VOR/LOC/GS CDI Page (8/12)

	CDI	NAV FLAG	SPR FLAG	TO-FROM
LAT				
VERT				
SELECTED COURSE				
DME CHANNEL MODE				

For new IFD installations, see Section 7.5.10 for selections and descriptions.

GNS-530/W or 430/W – VOR/LOC/GS ARINC 429 CONFIG Page (GNS-530W/430W Only)

	RX	TX
SPEED		
SDI		
DME MODE		

IFD – VOR/LOC/GS ARINC 429 CONFIG Page (9/12)

	RX	TX
SPEED		
FORMAT		
SDI		
DME MODE		

For new IFD installations, see Section 7.5.11 for selections and descriptions

GNS-530/W or 430/W– GPS Vertical Offset (if present)

GPS Antenna Height Above Ground	
---------------------------------	--

IFD – GPS Antenna Setup Page (10/12)

GPS Antenna Height Above Ground	
Antenna Type	

Note: Use the data recorded at the beginning of Appendix F to enter the Antenna Type field.

GNS-530/W or 430/W- STORMSCOPE CONFIG
Page (if configured for Stormscope)

STATUS:	MODE:
SW VERSION:	ANT MOUNT:
HDG FORMAT	HDG FLG SENSE
<input type="checkbox"/> HDG FLAG	<input type="checkbox"/> SYNC ANGLE
<input type="checkbox"/> HDG STAB	<input type="checkbox"/> SYNC REF
<input type="checkbox"/> HDG VALID	

Note: Squares should all be green if no issues.

IFD STORMSCOPE CONFIG Page (Software version 10.2 or higher)

Accessible via the TEST page, select GET DATA, scroll to Config, and record the jumpers installed and grounded

HEADING INPUT	J3-1 <input type="checkbox"/> OPEN <input type="checkbox"/> GND J3-2 <input type="checkbox"/> OPEN <input type="checkbox"/> GND
HEADING FLAG SENSE	J3-4 <input type="checkbox"/> OPEN <input type="checkbox"/> GND
ANTENNA MOUNT	J3-3 <input type="checkbox"/> OPEN <input type="checkbox"/> GND

GNS-530/W or 430/W – STORMSCOPE TEST
Page (if configured for Stormscope)

MODE
STATUS
TRIGGER COUNT
HDG

IFD – STORMSCOPE TEST Page
(Software version 10.2 or higher)

MODE
STATUS
TRIGGER COUNT
HDG

**GNS-530/W or 430/W– STORMSCOPE DATA
DOWNLOAD Page (if configured for
Stormscope)**

SOFTWARE VERSIONS:	
<i>Model</i>	
<i>Main SW Ver</i>	
<i>Main Boot SW Ver</i>	
<i>DSP SW Ver</i>	

**IFD – STORMSCOPE DATA Page
(Software version 10.2 or higher)**

SOFTWARE VERSIONS:	
<i>Model</i>	
<i>Main SW Ver</i>	
<i>Main Boot SW Ver</i>	
<i>DSP SW Ver</i>	

**GNS-530/W or 430/W – Traffic Config Page (if
configured for Traffic)**

ALT	
LIM A (if 429 interface)	
LIM B (if 429 interface)	
HDG (if 429 interface)	
BARO ALT <input type="checkbox"/> (if 429 interface)	
RAD ALT <input type="checkbox"/> (if 429 interface)	
TEST MODE? (if 429 interface)	

No IFD Equivalent Page

Note: Traffic monitoring is accomplished after a 3 minute suppression period in-flight when any faults are announced. There should be no Red-X on the traffic thumbnail if configured on the Setup pages.

Note: Check off the squares, as required, to match the solid squares on the GNS-530 unit.

GNS-530/W or 430/W – RYAN TCAD CONFIG
 Page (if configured for Ryan TCAD]

MODE	
APPROACH MODE	
HEIGHT	
RANGE	
GND/FLD ELEVATION	
VOLUME	
MUTE DURATION	
VOICE ALERT	
UNKNOWN DEVICE	<input type="checkbox"/> STATUS <input type="checkbox"/> MUTE

No IFD Equivalent Page

Note: Use the presence of the traffic thumbnail and the Audio Volume Control page to control these parameters in the IFD.

GNS-530/W or 430/W – GAD 42 Config Page (if configured for an ARINC 429 input from GAD 42)

MAIN RMI/OBI		ROLL STEERING	
NAV RMI/OBI		REMOTE CRS SEL	
SEL CRS DRIVE		TAS INPUT	
DIST SERIAL		GPS/NAV 429 L/H	
		HEADING 429 L/H	
GAD SW VER:			
STATUS:			

No IFD Equivalent Page

Note: Manually strap the GAD42 or ensure stored configuration is not lost. The IFD5XX/4XX alerts in flight mode if the GAD42 reports a fault.

**GNS-530/W or 430/W- TAWS Audio Config
Page 1 (if installed)**

TAWS CONFIG	
VOICE GENDER	
VOLUME	
PLAY AUDIO MSG	

No IFD Equivalent Page

(Use the User Options LSK and
Volume Control LSK of the Audio Tab instead)

**GNS-530/W or 430/W – TAWS Audio Config
Page 2 (if installed)**

ALERT	<i>Reduced Terrain Clearance</i>
CAUT	
WARN	
ALERT	<i>Reduced Obstacle Clearance</i>
CAUT	
WARN	
ALERT	<i>Imminent Terrain Impact</i>
CAUT	
WARN	
ALERT	<i>Imminent Obstacle Impact</i>
CAUT	
WARN	

No IFD Equivalent Page

(Use the User Options Tab instead)

GNS-530/W or 430/W – GDL Config Page (if installed)

ATTENUATION	
MODEL (if displayed)	

IFD – GDL Config Page (if installed) (11/12)

ATTENUATION	
MODEL	

GNS-530/W or 430/W – DATALINK DIAGNOSTICS Page (if installed)

QOS	TERR
SAT 1	SAT 2
TUNER	

IFD Equivalent Page

Note: Use the Datalink Status page on the AUX-SYS tab for datalink status data.

Notice:

SOFTWARE LICENSE: AVIDYNE CORPORATION (“AVIDYNE”) IS WILLING TO LICENSE THIS SOFTWARE, AND RELATED MATERIALS (THE “SOFTWARE”) ONLY ON THE CONDITION THAT THE USER AGREES TO THE TERMS OF THE PUBLISHED SOFTWARE LICENSE WHICH CAN BE ACCESSED VIA THIS WEB ADDRESS:

[HTTP://WWW.AVIDYNE.COM/SUPPORT/LICENSE.ASP](http://www.avidyne.com/support/license.asp)

FCC APPROVAL AND CAUTIONS: THIS DEVICE COMPLIES WITH PART 15 OF THE FCC RULES. OPERATION IS SUBJECT TO THE CONDITION THAT THIS DEVICE DOES NOT CAUSE HARMFUL INTERFERENCE. THE MANUFACTURER IS NOT RESPONSIBLE FOR ANY RADIO OR TV INTERFERENCE CAUSED BY UNAUTHORIZED MODIFICATIONS TO THIS EQUIPMENT. SUCH MODIFICATIONS COULD VOID THE USER’S AUTHORITY TO OPERATE THE EQUIPMENT.

