

**BABY GREAT LAKES  
SUPER BABY LAKES  
BUDDY BABY LAKES  
INFORMATION PACKAGE**

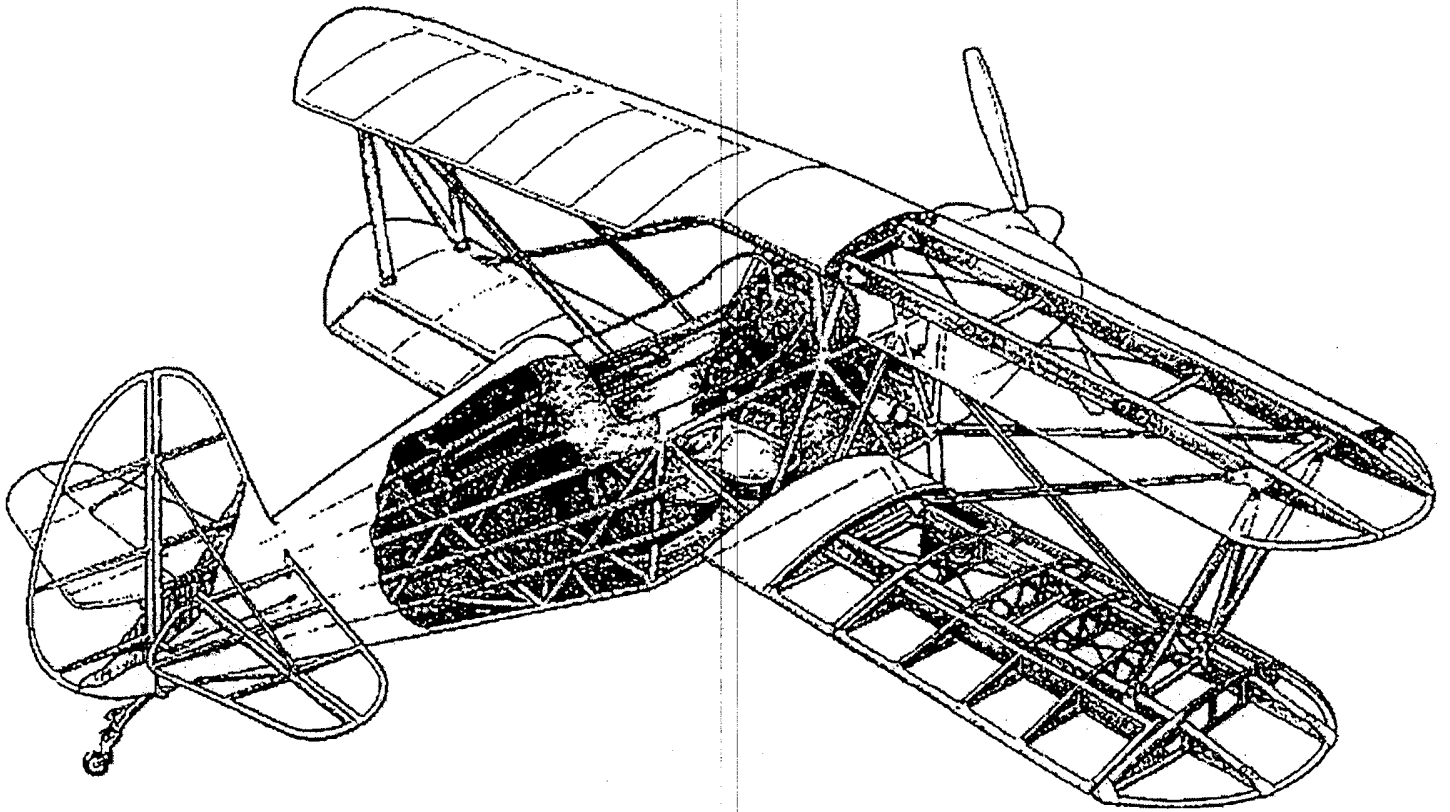

**Aircraft Spruce  
& Specialty Co.**

**1-877-477-7823**  
[www.aircraftspruce.com](http://www.aircraftspruce.com)



# Aircraft Spruce & Specialty Co.

Phone: 1-877-4-SPRUCE | International: +951-372-9555

---

Dear Aviation Enthusiast,

Thank you for your interest in the Baby Great Lakes series of homebuilt aircraft. As a distributor of kits for these aircraft for many years, we have had the pleasure of working with Harvey Swack of Barney Oldfield Aircraft Company in furnishing materials and components for the aircraft to builders worldwide. We are pleased to announce that Aircraft Spruce & Specialty Company acquired the rights to the Baby Great Lakes aircraft line recently and is now the exclusive source for plans and kits.

Throughout this information package you will find articles on the aircraft as well as general information which has been prepared and supplied to builders by Barney Oldfield Aircraft Company. All of this information is extremely valuable to builders of Baby Great Lakes aircraft, so we want to continue to include all of it in our information packages. All references to Barney Oldfield Aircraft Company as a source for plans or kits should be considered changed to Aircraft Spruce & Specialty Co. Plans and kits can be ordered by calling our Toll Free Number: 1-877-477-7823 or online at [www.aircraftspruce.com](http://www.aircraftspruce.com).

If you have not done business with Aircraft Spruce in the past, we welcome you to our family of the thousands of customers around the world that we have supplied with aircraft products since 1965. Give us a call soon to order your plans and materials for one of the three versions of the Baby Great Lakes. We look forward to serving you during your project which will certainly bring you a great deal of satisfaction in completing the aircraft as well as many hours of flying enjoyment.

Sincerely,

Jim Irwin  
President

## FLYING A BABY GREAT LAKES FLYING A BABY "LAKES" BY DICK LANE

Now, for flying the "Baby" the first time or for first-time-in-a-"Baby"-pilots, here is some information that might be helpful. Due to its very light weight and the lower wings close proximity to the ground, the "Baby" has, in effect, a double "ground effect" characteristic. If given full throttle suddenly, on take off the "Baby" will literally jump off the ground slightly before it actually has flying speed. Then, if allowed to continue climbing at the same rate (before airspeed reaches 65-70 mph), it will drop a wing as it leaves the ground effect and unless you are extremely quick you've slipped back down, touched the ground with a wing tip and Bingo! You've cartwheeled it! DEFINITELY NOT GOOD!! This phenomenon is the only "fault" one can find with the "Baby's" flight characteristics and this is not really a fault because once you get some experience with it, you can make some spectacularly short take offs that really make the hanger flyers and line boys take notice. KEEP IN MIND, ALL THIS TAKES PLACE IN ABOUT FIVE SECONDS.

THEREFORE!!! Until you have some experience follow this procedure and avoid problems:

1. Line up straight with the runway.
2. Neutral stick or slightly back to keep tailwheel on the ground while you build up speed.
3. Rudder neutral, remember the fixed or locker tail wheel will keep you going straight while it is on the ground.
4. EASE on throttle slowly allowing speed to pick up to 45-50 mph. At this point, the "Baby" feels very light, almost flying.
5. Now-gentle forward on the stick, try to hold it down, continue advancing the throttle. Steady on the rudder. It's the most sensitive control on the plane. Very small corrections have big effects.

As you gain experience you can speed up everything and get the thrills of your life, but at first take-it-easy. You'll always need that slight forward pressure just after leaving the ground. For landing, no sweat, the first time or two use a little power and maintain 75-80 mph over the threshold on final. You'll find that as you flare in ground effect it will take quite awhile before it finally touches down but still uses very little runway. KEEP THAT STICK BACK. Three point it every time and it will always stay straight. "Remember that fixed or locked tailwheel). Later you can do full power off landings easy. Coming down at a real steep angle at 65-70 mph with full control, flaring out and touching down in one smooth motion that uses up less than four hundred feet of runway.

For your first flights avoid gusty, cross-winds or any winds higher than 15-18 mph as these have a tendency to aggravate the normally unstable tendencies during the transition from taxi to flying speed or vice-versa.

Later, with experience, you'll fly in perfect comfort and safety in 25-30 mph cross winds though you might like me, on occasion, scrape the bottom of a lower wing tip on a particularly gusty landing. No harm done if you've had the foresight to put metal skid plates on for paved runways. Turf no problem.

Well there you have it. I've flown hotter, trickier, more exotic airplanes but never one more fun to fly nor more responsive. The Baby's not as forgiving as a Cub or Aeronca because its quicker by at least 10 times but its just as easy to fly if your reactions can meet its pace. Its true, it will fly hands and feet of f and it does right itself, when trimmed after being upset, in a couple of oscillations.

A few more points. The heavier the pilot is the further aft will be the C.G. This makes it trickier and increases the speed required for effective control and take-offs and landing. The Baby is extremely sensitive to weight. For every twenty-five pounds of pilot weight above one-hundred-fifty pounds you need another inch of engine mount length with the standard 47<sup>1</sup>/<sub>2</sub> in. cockpit fuselage size. When you increase the cockpit length at the firewall you are moving the C.G. ahead automatically so don't add engine mount length unless you weigh over two-hundred pounds.

So if you weigh more than one hundred seventy five pounds and are over five feet eight inches tall, build the fuselage with the three inch extension at the firewall and make it wider in the cockpit twenty five pounds over two hundred twenty five pound pilot weight except with Lycoming engines, with the lycoming engine keep the mount as short as possible ten inches.

Finally, read and re-read what is said here as this is exactly what we told people in checking them out in 11311 and 181 (knock on wood) so far we have had no problems except with high time commercial and A.T.R pilots who refused to listen. Keep in mind, several thousand hours driving limousines and busses does not qualify one to drive a hot sports car or motorcycle!



## Oldfield Baby Lakes, Super Baby Lakes and Buddy Baby Lakes

*Champagne performance on a beer budget!*

### General:

The Baby Lakes is a small, single place open cockpit biplane that can be flown year round with the addition of a canopy. It is fully aerobatic with no restrictions and stressed to 9 G's positive and negative at its maximum gross weight of 850 lbs. The design is well debugged having been in existence for over 20 years. The Baby Lakes can hold pilots weighing from 120 to 220 lbs. Instructions are included to customize the cockpit area to take pilots of different sizes, too!

### Plans and Construction

The Baby Lakes is well engineered and designed to CAM part .03 (FAA design criteria applying to biplanes). Drawings are complete and detailed, many templates are full size, construction manuals are clear, readable and easily understood. Standard aircraft materials and hardware are used. NASAD rating: Class 1.

### Kit:

Short description of kits - this aircraft is primarily built from the plans with material kits supplied by Aircraft Spruce & Specialty Co. Welded components and parts are available. Material kits are grouped into tubing, wood, aluminum, fabric, paint, hardware, etc.

### Construction:

Conventional aircraft construction techniques are used throughout. Fuselage, tail group, and landing gear are welded tubing, wings are made of spruce spars and built up ribs. A rib jig of one size is used to make all the ribs. The experience in building this aircraft will give you skills in woodworking, welding, metal worked and simple aircraft fuel systems.

### Performance:

Varies considerably with engines used. 60 to 70 h.p. engines give 110 to 115 cruise and 1200 - 1500 fpm climb. 75 to 100 h.p. engines permits 1500 to 2000 fpm climbs and a cruise of 118 mph. The Super Baby Lakes uses 108 to 125 h.p. and climbs over 2500 fpm, cruises at 138. Range for all is 250 miles and stall is 55 mph power off.

### Information:

An extensive information packet explaining the design philosophy for each of the three airplanes also contains Cut-a-way drawings. Price sheets, kit information, complete performance data is available for \$5.00 for all three items.

### National Association of Sport Aircraft Designers Qualitative Ratings:

- Quality and completeness of drawings ..... **Superior**
- Clarity of drawings and manual ..... **Superior**
- Complexity of construction ..... **Simple**
- Complexity of piloting ..... **Basic Skills**
- Completeness of kit ..... **85% Complete**

In summation, the Baby Great Lakes is:

- Economical to construct (requires no jigs, uses all standard hardware materials readily available)
- Easy to maintain (a 100 hour check can be done in 2 hours)
- Easy to fly
- Exceptional performance
- Good in appearance

# US AVIATOR



Featuring The ENTIRE World Of Avionics  
The "US Aviator" — World's Greatest Aero-Magazine  
Copyright 1991, Airedate Press Inc., All Rights Reserved

Publisher/ Editor-in-Chief: James R. "Zoom" Campbell.  
Managing Editor: Ken "Stealth" Cooke.

## Barney Oldfield Baby Lakes

It may look like a kid's toy , but the Baby Lakes, originally designed by Barney Oldfield, ain't no little red wagon with wings. It' s a high-performance, aerobatic airplane for folks with caviar tastes and scrambled egg budgets. The original Baby Lakes design has been around for more than 30 years, and it's been modified slightly in the development of the tandem-seat Buddy Great Lakes. Here's some figures that remain the same for both models: Top speed, 135 mph; cruise, 118 mph; landing speed, 55 mph; rate of climb (pilot only), 2000 fpm. And those numbers are with a C-65 engine. With a heftier powerplant, you can easily see a top speed of 155 and a cruise of 135 mph.

At only 4 feet 6 inches tall and a wingspan of only 16 feet 8 inches, the Baby Lakes makes even the littlest pilot feel like a Goliath. But even Goliath wasn't built as well as the mini-copy of the Great Lakes. The critical wing and wire attachments have been stress tested to more than 10 Gs without failure. In-flight pull-outs have been made to 7.5 Gs. If you're more into bush operations than airshow performances, you'll find the oleo gear is wide and fairly soft, making rough field operations a breeze.

There are so many variations available to the Baby Lakes, Super Baby Lakes and Buddy Baby Lakes that it's impossible to estimate what a "typical" one might cost or how long it might take to build. Plans, new instructions and newsletters are available at \$150 for the Baby Lakes, \$175 for the Super Baby Lakes and \$200 for the Buddy Baby Lakes. FMI: contact Barney Oldfield Aircraft Co.,

Zoom Report: One of my very favorite airplanes. A Baby Lakes with more than 85 hp will kick a 150 hp Pitts S-1C out of the box. Delightful on the ground, agile but not scary in the air , the Baby Lakes may be the perfect small sport aircraft. With a strong structure and a 25 year history, the Baby Lakes is a no-risk choice... highly recommended. Grade: A+

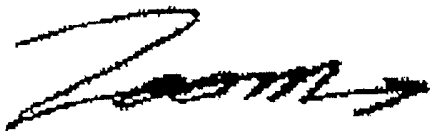

J.R. "Zoom" Campbell  
Auto-Rotating Editor-Publisher

## BUDDY BABY LAKES

Harvey Swack was raised on a farm near West Salem, Ohio, but despite the fresh air and exercise, contracted incurable airplanitis at an early age. Complications and side effects included a hopeless addiction to aviation books and magazines and extended bouts of model airplane building. Treatment included forced abstinence while obtaining his college degree and, later, a Masters in education from Ohio State, and, finally, occupational therapy in the form of a teaching position in the public schools of Mansfield, OH. All was to no avail, however, so after four years, Harvey gave in completely to his malady and opened a hobby shop in Mansfield, specializing, of course, in model airplanes. The emergence of the big discount houses eventually forced him out of this endeavor and into a career administering municipal parks and recreation programs in Cleveland . . . but by this time his condition had advanced to the stage of flying real airplanes, so any hope of recovery was, of course, irretrievably lost.

In the mid-1960's Harvey was doing some writing for Air Progress magazine and among other projects, compiled a list of all the aircraft for which plans were then available. The editors were sufficiently impressed with the material

that they created a separate magazine around it. Harvey updated the list for new annual issues for a couple of years . . . and in the process, carried on a personal search for plans for the Great Lakes Sport Trainer (which had been manufactured in Cleveland in the late 1920's and early 1930's) because he wanted to build a replica for the EAA Museum. Eventually, his Great Lakes quest brought him to the FAA, where he was able, initially, to obtain a set of engineering drawings from government records and an O.K. to build one airplane. (Ultimately, Harvey was able to obtain the rights to the Great Lakes Sport Trainer and sold plans for a time. He later sold the design to Doug Champlin who put the airplane back into production with a modern engine . . . but that's another story.) While he was involved with the FAA on the Great Lakes rights, an inspector asked, "Harvey, why bother with the old Great Lakes, you ought to be building a Baby Great Lakes. You ought to call this guy Barney Oldfield in New York. He's got a great little airplane that outflies anything for the power." With such a ringing endorsement from an FAA inspector, Barney decided he'd better look up this Barney Oldfield.

Harvey called Oldfield, got the information on the airplane's performance . . . but had a hard time believing the numbers after comparing them with the other midget biplanes available at the time. To get some other opinions, he got in touch with a couple of pilots who

had owned the prototype, N9Y, and, sure enough, received only glowing reports on the little bird. One of the possible explanations, he concluded, was the fact that N9Y had an empty weight of just 480 pounds.

About two years later, Harvey received a call from Oldfield. He had so many projects, he said, that he was willing to part with the prototype. The price was right, so Harvey bought the airplane and with it, ultimately, the rights to the design. After a careful study of the airframe, he became convinced the Baby Great Lakes was something that should be shared with homebuilders everywhere. He got back in touch with Barney and asked for the drawings, but discovered that none existed. A genius in many respects to those who knew him, Barney had much of the Baby Great Lakes information in his head. The only thing on paper was in a little notebook . . . and that consisted simply of page after page of numbers. Apparently, they represented stations along the lengths of the fuselage; the flying surfaces, landing gear, etc., with appropriate dimensions. Barney was the chief engineer of a large optical company in Canada then and really didn't have the time for such a project, but he agreed to translate his hieroglyphics into something a homebuilder could follow. He and an assistant made up drawings based on the second airplane, which he was working on at the time. That airplane, N11311, would later be donated to the EAA Museum by Harvey

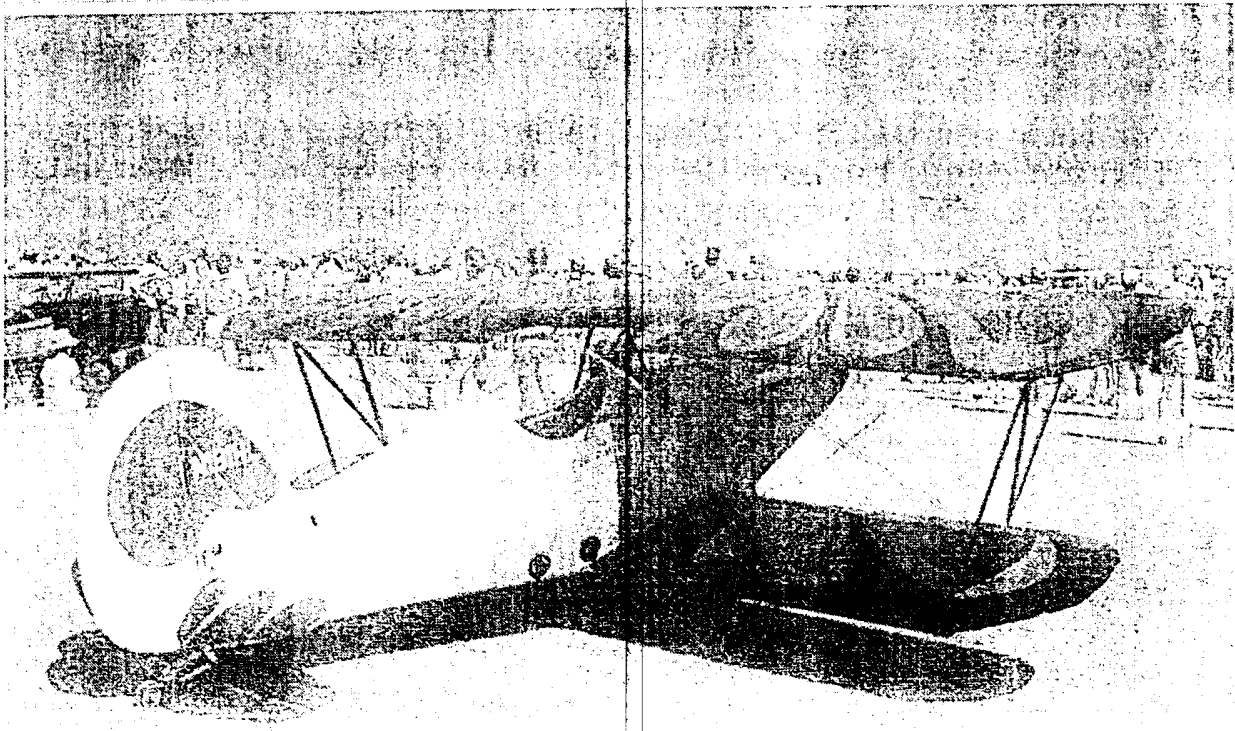

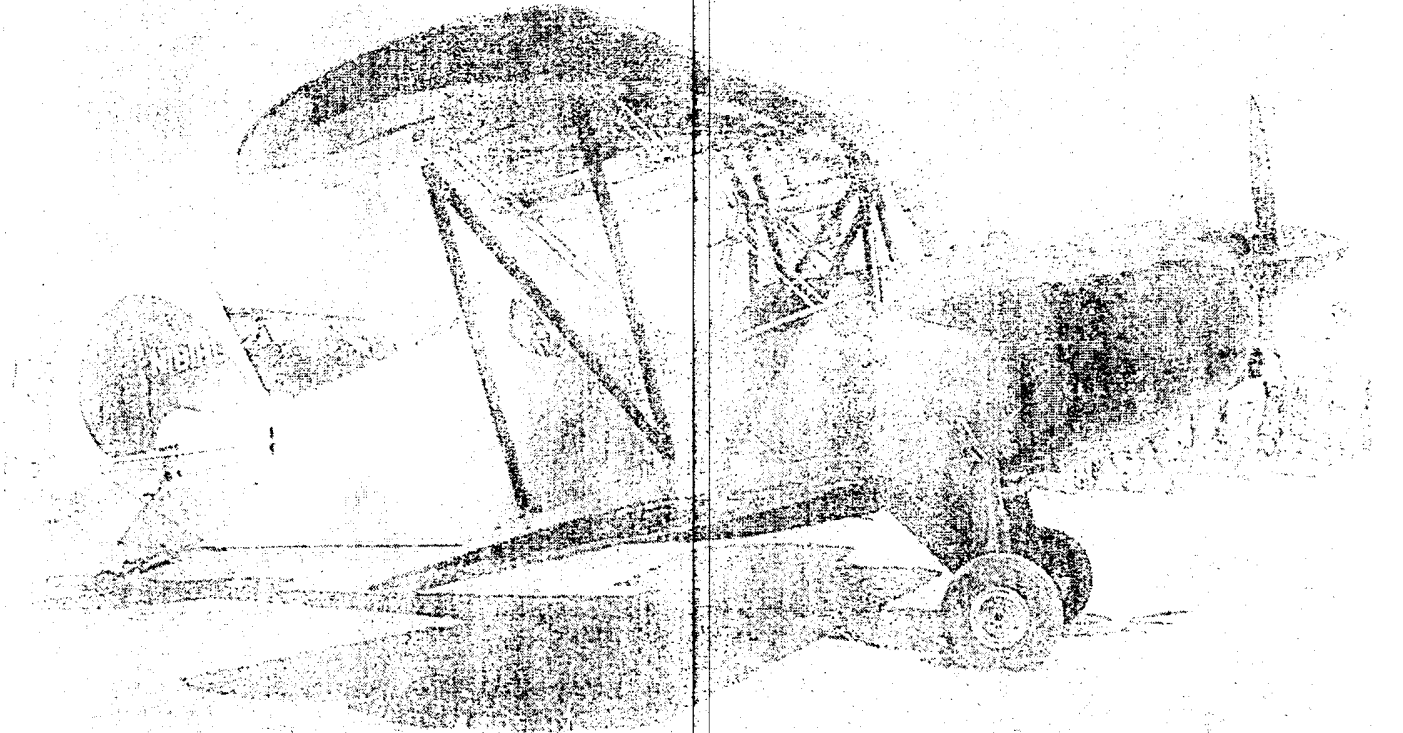

Jack Cox

**Swack.**

In 1970 Harvey met a second person involved in the Baby Great Lakes development and began an association that has been as important as the air-

craft itself. Dick Lane grew up in Ithaca, NY and learned to fly in a J-3 in 1945. After high school, he obtained his A&P license from Spartan School of Aeronautics and, as he likes to say, has "been playing with airplanes ever since." He has worked in the aviation industry but has kept his personal flying more or less a hobby over the years. For the past 10 years he has been employed as an engineer with the Airborne division of the Parker Hannifin Corporation in Elyria, OH. Over the years, he has owned an Aeronca K, a Luscombe (which he still has), a Bellanca 14-13,

Dick Lane and Sally Cole demonstrate the "buddy" seating of the Buddy Baby Lakes.

and a Cessna 182, just to name a few. In addition, he built the replica of the 1921 De Pischhoff "aerial scooter" that was shown at Oshkosh in the mid-1970's . . . and he has built five Baby Lakes! (The name Baby Great Lakes was changed to simply "Baby Lakes" when Harvey sold the Great Lakes rights to Doug Champlin . . . to avoid any confusion of products.)

Dick had met Barney Oldfield some-



time in the mid-1950's and helped him build the second example of the Baby Lakes. It was Dick, in fact, who flew N11311 to Oshkosh in 1970. Unfortunately, Oldfield would die later that year and Dick says that when he visited him in the hospital, he would chase everyone else out so they could talk about the Baby Lakes. He was very proud of the design and believed it would be his legacy to aviation, Dick says.

Harvey and Dick met that year and subsequently Dick has become Harvey's technical consultant, his builder and pilot for the project. Harvey handles the marketing and correspondence with builders and Dick fields the technical questions . . . and now that the Buddy Baby Lakes is flying, gives demonstration rides. Theirs is a split operation these days. Harvey retired from his parks and recreation position in Cleveland four years ago, but his wife, who is a college professor, was still working and recently had the opportunity of a new position in Boston. Not only did the Swacks move to Massachusetts, but now Harvey has also begun college teaching there on a limited basis. His heart, of course, remains with flying and, particularly, the Baby Lakes.

For recent members of EAA, the Barney Oldfield Baby Lakes is one of the smallest and lightest of the midget biplanes that are available in plans and/or kit form. Construction is typical of the type: welded steel tube fuselage, tail surfaces, landing gear, cabane and wing struts; wood wings and fabric covering. The original version was intended for engines ranging from 50 through 100 hp, but a subsequent model, the Super Baby Lakes, is stressed for engines up through 125 hp. Span is just 16 ft. 8 in., the length is 13 ft. 9 in. and the wing area is only 86 sq. ft. for both models. Empty weight of the original model is 480 pounds and the Super Baby Lakes weighs about 500 pounds. Both have a gross of 850 pounds and are stressed for 9 G's positive and negative. The chief virtues of the design are good performance on low power and a relatively low cost to build.

Ask any designer who has started off with a single place airplane and he will tell you that the most frequent question he gets is, "When are you going to offer a 2-place version?" This was a particularly thorny problem for Harvey because getting into the air with a fully aerobatic airplane at minimum cost was the biggest selling point of the Baby Lakes. Further, it had always been his experience that 2-place open cockpit airplanes fly with just the pilot aboard the vast majority of the time . . . so he was very reluctant to try to develop a larger, heavier, more expensive version

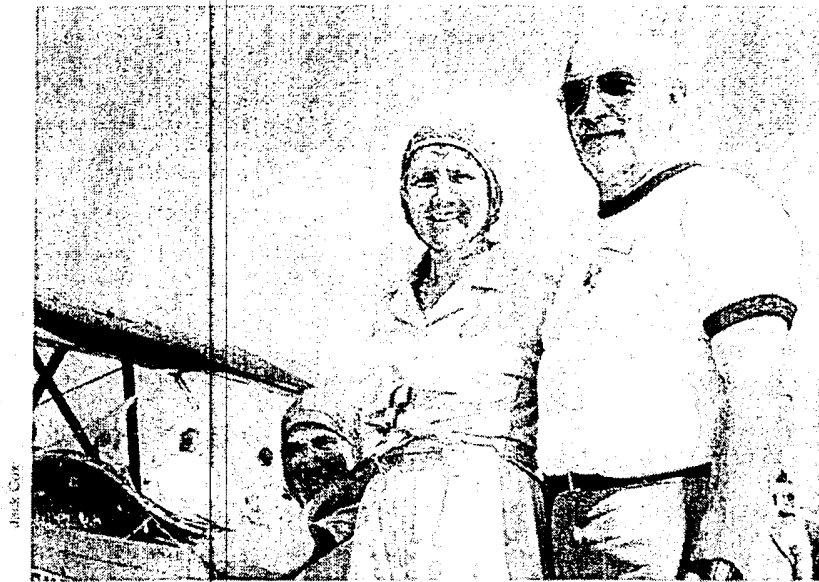

of the Baby Lakes. He and Dick Lane discussed the matter many times over the years and, eventually, Dick came up with an idea that seemed to Harvey to be the ideal compromise: an "occasional" 2-seater. Perhaps Dick got the idea from the De Pischoff replica upon which the pilot sat astraddle just as if on a motorcycle . . . in any case, he conceived of a Baby Lakes with just enough of a stretch in the fuselage to allow a single cockpit long enough for a second person to sit immediately behind the pilot, in the same way a passenger sits on a motorcycle. The more he thought about it, the better Harvey liked the idea . . . because it was a solution to a number of problems. It would fill the bill for the father or grandfather who wants an economical little open cockpit biplane in which he can do aerobatics, but has a "buddy" seat in which he can occasionally take his children or grandchildren for rides . . . or his wife, if she weighs 110 to 120 pounds. It would also be a solution for the seemingly inevitable 225 to 280 pound pilot who for whatever reason seems to be drawn to the very smallest of airplanes like a moth to a flame. Those big fellows could, of course, fly it as a single place airplane. Finally, such an airplane could be used to check out builders about ready to fly their single place Baby Lakes. It was just too good of an idea to pass up. Harvey decided, so he gave Dick the go-ahead to build what they would name the Buddy Baby Lakes.

Dick Lane describes the finished product he flew to Oshkosh this past summer:

"What we've done is simply enlarge the fuselage enough in the cockpit area so we have an extra seat right in behind the pilot. We put in a second set of rudder pedals and a second throttle, but

Left to right, Dick Lane, Sally Cole and Harvey Swack.

we have just one stick. It is S-shaped, however, and the upper half of it telescopes over the bottom half and is held in place with a pin. The pin is easily removed to allow the upper portion to be swiveled around 180 degrees. This way, when the airplane is being flown solo from the rear most part of the dual seat, the stick swivels back within easy reach and is pinned in that position. When a passenger is carried, it is swiveled to the front. Actually, it can still be reached even by the person in the rear seat . . . by reaching around the person in front. That's what I do when I'm checking someone out in the airplane.

To achieve this kind of seating arrangement, I started with what I call a proof of concept modification to a standard single place Super Baby Lakes, chopping the fuselage in two and putting it back together using internal sleeve splices. I lengthened the thing 6 inches from what used to be Station 47, which is the seat back in the single place airplane. I shoved the fire wall ahead 6 inches and repositioned the landing gear 3 inches further ahead. The tail post was moved back 5 inches. The net result was a fuselage 11 inches longer than that of a standard Baby Lakes. The landing gear legs are a couple of inches longer than the single place airplane, the idea being to keep the deck angle exactly the same. I want a deck angle that translates into exactly the right speed for liftoff and touchdown. The airplane works the nicest with a three point take-off and a three point landing. The Buddy Baby Lakes needed more wing area, but I didn't want to have to design and build new wings, so





# Aircraft Spruce & Specialty Co.

Phone: 1-877-4-SPRUCE | International: +951-372-9555

a center section was built for the top wing and little 6 inch stubs were added to the side of the fuselage for the lower wings to attach to . . . all this so the standard single place wings and most of the flying wires could be used. Only the front flying wires are different - they are much longer. The tail surfaces, the motor mount and the struts are the same as on the single place. The airplane came out with an empty weight of 600 pounds, which obviously can be made lighter when a Baby Buddy Lakes is built from scratch, because it won't have all the sleeves and such. The prototype is powered with a 115 hp Lycoming O-235 and a 66.5" x 52" prop, which produces phenomenal acceleration and climb. Even with two aboard, it is comparable to a single place Baby Lakes with 100 hp and a 150 pound pilot, in terms of take-off distance and climb. It cruises at 130 mph indicated with this prop and would, of course, go faster with a higher pitched prop. We have to use a short prop in order to have adequate prop clearance.

"The airplane is not something you can give dual instruction in, per se. It is really designed just as a way to give a check ride in a single place airplane. I might take this opportunity to mention that the biggest problem builders have with our designs is in the rigging. Most people don't know how to rig a biplane and this one is rigged a bit differently than most. Barney designed the thing so that in level flight, you'd be flying on the top wing only, so as to give it a heavier wing loading. The bottom wing is just streamlined and when you do a roll, you don't get any asymmetrical yaw because of more drag on one wing than the other. The control response is very light in pitch and the rudder is very light, but the ailerons are significantly heavier because we don't have a Frise type aileron or external spades or anything like that. With them you could get a better balance of stick forces, but Barney never considered that as important . . . and having flown these things since 1970, I guess I don't consider it terribly important either, for what we are trying to do with the airplane. The airplane is stressed well in excess of anything you can put on it. It has been through stress analysis by a couple of competent aeronautical engineers, both of whom came to the same conclusions. It is good for 9 G's positive and negative at gross, but I have never been able to pull even 6 G's. It unloads into a snap before it will ever get to 6 G's. Of course, like all airplanes, it can't stand a big impact with the ground."

Harvey says that today, some 20 years since the plans were first put on the market, he still sells 25 to 30 sets a year. "It just keeps going on. We're not

trying to set the world on fire, it's just an enjoyable thing to do. I hate to use the word 'selling.' I call it sharing, because ours is a non-profit venture. I don't do this for a living, never have and I don't want to because I feel that the original purpose of EAA was education and recreation and if we break even and cover our post, that's fine with me. That's what we do . . . it's a matter of sharing information and we've been at it for a long time. I issued serial number 1,007 about a month ago. This carries over into our dealing with our builders. We find that people don't always grasp the clever things that Barney designed into the airplane to protect the pilot. The special sweep back of the wing, the dihedral . . . if you get into an inverted spin in this airplane, you pull the power back and it will pop right out of the spin. Because we want the airplane built exactly like we show it on the drawings because of its special features, we are pretty hard nosed with people who want to change it. I say, 'Don't build the airplane. Either build it the way we show it or don't build it.' I have a lot of respect for people who want to design and build their own airplane, but when you take a design that has been around this long and has proven so successful, you don't want to mess with it.

"We do get a lot of good input from our builders. We have rewritten the building instructions five or six times over the years, largely due to the good ideas we get from builders. Paul Kepner of Garland, TX and Bernie Holloway of Waupun, WI have been responsible for updating the instructions."

If you want more information on the little biplanes that offer "champagne aerobatic performance on a beer pocketbook", as Harvey says in his ads, buy one of his \$10.00 info packs. The address is: Barney Oldfield Aircraft Company, P.O. Box 228, Needham, MA 02192.

**Reprinted from  
EAA  
SPORT  
AVIATION  
December 1988**

## FLYING THE SUPER BABY LAKES

By Dick Lane

One of my biggest thrills at the 1977 Oshkosh EAA Fly-In occurred when Harvey Swack invited me to fly his pretty Butterfly Baby Great Lakes, N181H, around the fly-by pattern. I'd flown formation with a number of other Babys, including Joe Mason's beauty, N741Z, so I really enjoyed this opportunity to actually fly one.

Another tiny biplane at Oshkosh '77 was Ray Ball's Super Baby lakes, N362RB, with a bigger engine, the Lycoming O-235, of 115 hp. Built by Ball and Dick Lane of Fulton, N.Y., it was so impressive we asked Lane to do a pilot report for Homebuilt Aircraft. This is his story. — Ed.

**The First Time** I flew a Baby Lakes — back in 1970, from A.H. "Barney" Oldfield's little 1400-foot grass strip — it was a really thrilling experience. The emotional and physiological reactions it caused were very similar to the ones I have enjoyed whenever I've had my hands on the controls of a variety of racing cars, racing hydros, or even the hopped-up Harley-Davidson motorcycle I once owned.

On reflection, it's not so much the speed that turns me on, but rather the quickness, the fantastic sensitivity and instant response to, it seems, the mere thought of the next maneuver. For me — just great! The ultimate high, for a non-personal type of experience! I suppose when anyone

is affected by this type of exhilaration and excitement it becomes almost addictive. One never really gets enough. Fortunately, some machines are capable of providing the thrill, albeit an old familiar thrill, time after time. Just like a ride in a racing car or boat, each flight in the Baby Lakes continues to be an exciting adventure.

As with most adventures, however, when you repeatedly fly the Baby Lakes, some of the "edge" wears off. Familiarity develops from the experience, testing your skills and breeding confidence. But like any real thoroughbred, the Baby lakes will never let you become so familiar that you can approach any flight with casual indifference. Though relatively easy to fly, it demands a degree of proficiency and experience; it insists on all your attention all of the time, except in straight and level flight.

Even after a couple of hundred hours in a Baby, it is still an adventure every time you fire the throttle. Though used to it, you still feel a quickening of the pulse and the flush of anticipation as the Baby leaps from the runway and races for the clouds in one great, happy bound.

Did I say "used to it"? Guess again! All of a sudden the original first excitement and heart-pounding exhilaration is back because a "Super Baby" mutation has been born! It's the same delightful

machine to fly as before, but an enlarged heart gives it an impatient urgency that is breathtaking by comparison.

Even though stressed for loads way beyond any that I have been able to subject it to in any flight maneuver, the Barney Oldfield Aircraft Co. never recommended more than 100 hp, due to its very small size and light weight. Up to now it was felt, and rightly so, that its performance on 65 hp was good enough, so that 100 hp would be more than enough to satisfy anyone short of an out-and-out serious expert or unlimited competition aerobatic pilot.

After all, when built carefully to the plans and equipped with the right propeller, on an 85 hp Continental, the Baby Lakes can reach 2000 feet altitude AGL from a standing start in one minute, cruise from 70-125 mph (depending on selected power setting), and top out at over 135 mph indicated without exceeding engine redline. Couple this with a capability of taking any and all aerobatic maneuvers that you and your fuel and oil delivery systems are able to handle, and you've got a pretty impressive machine — and at one half the cost of anything comparable.

But some people are never satisfied. In Fulton, N.Y., Ray Ball started construction on a Baby Lakes a few years ago. He had flown Baby N11311, which is now on display in the EAA Air

Foundation Museum and is the second (Serial #2) Baby built by Barney Oldfield himself, with the help of a friend. Construction was barely started on Roy's Baby when he had the opportunity to pick up a Lycoming O-235 at a very good price. When he asked me if I thought it could be used in the Baby, I replied, "I don't see why not, and it ought to be a real tiger!"

We worked out the adaptation, and the resulting performance is phenomenal. Through my considerable experience with the Baby Lakes airplanes, those built with Barney and several others as well, I have become increasingly aware that the performance is radically affected by weight, and quite significantly by horsepower. For example, the performance of a Baby with 65 hp Luscombe 8A flown solo, due to the comparatively high drag of the Baby.

Conversely, in the same performance terms it takes a 150 hp Luscombe conversion to compare with the 100 hp Baby. In either case, control response and maneuverability in the Luscombe is definitely on the order of a "lumber wagon" in super-slow motion, compared with the Baby's agility, regardless of its horsepower or loading.

## **BABY GREAT LAKES HISTORY**

It was back in 1958 that Barney Oldfield, a talented designer of lens-grinding machinery, fell in love with the old Great Lakes 2T-1 Sport Trainer, which first appeared

at the National Air Races in Cleveland in 1929. When the lens-grinding firm folded, Oldfield bought the ATC and scaled down the plans but it didn't work. So he started afresh, hoping to develop a tiny look-alike biplane and have it certified under FAR Part 21.

When completed, the original Baby Lakes was certified by FAA Inspector Robert DeYell, who suggested to Oldfield he draw plans and sell them to homebuilders. Eventually Harvey Swack, of Cleveland, Ohio, financed N181H (the Butterfly), while another personal pal of Barney's, Dick Lane, completed another, N11311.

In 1970, Oldfield hoped to launch the Baby Lakes business at Oshkosh, but before he finished N11311 it was discovered he had cancer. At Waterloo, N.Y., shortly before his death, Oldfield struggled into the small cockpit, taxied it down the runway, and told Lane: "She's fine, Dick! Go ahead and fly her!"

Lane flew the initial test hop and at first found the ship squirrely on takeoff but fine on landing. When he got used to the way it handled, he flew it to Oshkosh with a Student Pilot friend, Dave Hamm, flying chase in a Cessna 140 — his first cross-country flight.

Harvey Swack was delighted with the ship, and although eight other pilots flew it, Oldfield was too ill to take it up. "She's my immortality", he told his daughter Cathy.

More than a score of Baby Lakes are flying today in the United States, great Britain,

Canada and Japan — most of them with 65-85 hp engines.

Ray Ball's Super Baby lakes is different from the others, with its O-235 recovered from a Piper Clipper wreck lodged in a treetop. Stripped of accessories, it weighed 240 pounds, and with some plans changes it fitted the airframe well.

The Super Baby cruises at 135 mph TAS on 75 per cent power, has a Vmax of 155, climbs 2500 fpm and can take off and land in under 350 feet.

## THE OLDFIELD BABY GREAT LAKES STORY

By Barney Oldfield



Flying is fun! It is also a sport. It is relaxing - could be adventurous. It can also be dangerous and sometimes fatal.

I am dealing with fun and sport in this article. Which I hope you will read in its entirety

It is very difficult to say why I designed and built the Baby Great Lakes, but perhaps when I say what I wanted to accomplish, the "why" may become evident.

I have always wanted to fly and from a small boy to now I have always felt an airplane need not be monstrous in size. A small airplane does not need as much material, hence a smaller engine is in order. All things become proportional except in many cases, airplanes of reduced size from the norm of 25 or 30 feet span, become difficult to fly and, of course, flying skill has to be greater. It goes without saying that a "hot" or tricky airplane has no place in a grassfield operation. So, we need an airplane which an average or below-average pilot can fly and have a little fun too.

I now think I know what kind of an airplane I want:

1. It need not be large
2. It must be strong
3. It must be easy to fly
4. It has to be economical to fly in the strictest sense.
5. It must have short field performance
6. It should operate from poor fields.
7. It should be easy to maintain

There are no commercial airplanes which fit all these requirements.

- Some fly well
- Some will have high cruise
- Some are beyond the average pilot's income

It becomes quite clear at this point that a slightly different airplane was needed. With the liberal attitude of the CAA (now FAA), a special purpose, I.E. home built was in order. Having owned and flown a Great Lakes Trainer for several years. I thought this was what it should fly like, and look as near as possible, too have some fundamental knowledge of how a biplane works and so out we go! We found that in practice span loading in excess of 30 lbs. per foot didn't work at high ceilings and anything over 10 lbs. per square foot came in fairly fast. So at 850 lbs. I need about 28' of wing span. So now we have 16' span upper and 14' lower minus the fuselage. We now have the chord, too. I decided to use Jimmy Romberger's (last address, Florida) list of proportions and used them in aspect ratio - no more than six, no less than 4.

<b>Stagger</b>	30% of cord
<b>Gap</b>	Not less than 100% or more than 125%
<b>Overhang</b>	50% of cord max
<b>Aileron</b>	11% of wing area
<b>Stab. elevator</b>	9% of wing area - 5% stab. 4% elevator
<b>Rudder fin</b>	7% of wing area - 4% fin. 3% rudders
<b>GG to rudder post</b>	no less 3 x cord. nor more than 4 1/2 cord
<b>Sweepback</b>	no more than 25% of CP
<b>Dihedral</b>	30% depth of C maximum

Using three factors as a guide, the Baby Great Lakes evolved.

I wanted as much cruise as I could get with a biplane and as much stability, so I put the bottom wing at 1 1/2° incidence and the top wing at 2 1/2°. The idea being at high cruise the bottom wing is almost streamlined, and you actually are flying a parasol which is probably why it handles very well in rough air. I left slots between the stabilizer and fin to allow air through at high angles of attack and have solid rudder throughout a stall. Any frill you don't really need should be left out. Every pound becomes 10 in. strength requirements! It has been said every extra pound costs a hundred dollars worth of fuel to haul around in the normal life of an airplane. So if you don't need it, leave it in the hangar or on the shelf. Hence we have no seat, just

cushions! (We do have securely fastened seat belts and shoulder harnesses). The minimum required instruments for VFR flights. There is room for a radio, as by the time you are finished, it will probably be required.

A couple of friends that operated the old Auburn Airport. Lee Ingalls and Frank Nugent, gave me two wing spars from a Waco CG-4 Glider. I cut many spars out of these and had enough material to make all of the capstrip material. I made the ribs first, as this is the most tedious job of all. Then came the wing fittings. Now on to fuselage, landing gear, empennage, and covering. I would like at this time to thank George Smith and Robert Deyell, who were the chief inspectors in our Safety Office in Rochester, New York for their encouragement and cooperation. I had no difficulty in meeting the standards and requirements as prescribed by CAA which are only intended for the best interests of everyone concerned.

So comes the day to fly the airplane which carried Serial #1 registration N9Y. I tried to taxi it up and down the runway. The runway was 100' wide, but too narrow! I ground looped it. A tail skid is omnidirectional, especially on gravel. I was keyed up to such a point by now that I did not want to postpone the initial flight. Having heard that a person can fly better in moc-casins (as opposed to G.I. Shoes) I put on a pair. This helped a little. So here I am with all my advisors and

friends watching to see if I really can build an airplane and be able to fly, waiting to have decisive proof. I decided to try a five second full throttle run and see what happens. It felt much better under power than without. Well, I watched the sweep second hand hit 12 o'clock and pushed the throttle open and steered it down the runway. Before I hit the five second mark I was in the air, flying solid! I had to pick up the right wing as it was a little heavy. I made a large shallow turn pattern and came in for a landing. It started to swing a little but a little power stopped the ground looping tendency. I later went to a locked tail wheel and to date this works fine, the ground looping evaporated.

It took only three weeks to get the necessary 50 hour restriction lifted, thanks to many of my friends. Harold Culver did most of the aerobatic testing at Geneva, New York. I flew the plane for over three years and sold it to Jack Long, also of Geneva, New York. He flew it another three years and sold it to Wynn Rabidou who has since sold it.

I still like to see the plane and find it difficult to realize that I designed it and built it and flew it. I get a sense of personal satisfaction, of accomplishment and pride when I am told another pilot has flown it and likes the way it flies. I feel that I now have a grass field midget that will go in and out of any field that any other airplane can.



## THE OLDFIELD BABY GREAT LAKES

### Specifications:

Configuration:	Biplane
Type of construction:	Tube fuselage Wood wings
Engine (s) - (no., make, model, rating)	Continental C-85
50 to 125 hp recommended	85 hp
Wingspan (ft./in.)	16' 8"
Cord (in.)	36"
Length (ft./in.)	13' 9"
Height (ft./in.)	4' 6"
Wing area (sq.ft.)	86
Number of seats	1
Gross weight (lbs.)	850
Useful load (lbs.)	375
Empty weight (lbs.)	475
Fuel capacity (gal.)	12

### Performance

Maximum speed (mph)	135
Cruising speed (mph)	118
Initial climb (S.L., fpm)	2000
Stall speed (mph)	50
Take off run (ft.)	300
Landing run (ft., w/o brakes)	400
Service ceiling (ft.)	17000 +
Maximum range (mi.)	250

**Note:** The 65 hp continental engines are plentiful and the least expensive aircraft engine available. Spare parts will never be a problem. We recommend, urge and suggest you consider using this engine as a first choice. The drawings for the Oldfield Baby Great Lakes are presented in 20 large sheets as follows.

<b>General Aircraft Assembly</b>	<b>OGL 1-1</b>
Motor mount (Continental)	-2
Interplane struts	-3
Undercarriage	-4
Cabane struts	-5
<b>Wings-assembly</b>	<b>OGL 54-2-1</b>
Ribs	-2
Wing tips	-3
Wind screen	-3B
Spars	-4
Aileron	-5
<b>Fuselage-Welded Assembly</b>	<b>OGL 54-3-1</b>
Sections (sheet 1)	-2
Instrument panel and formers	-3A
Firewall	-3
Fairings	-4
Fuselage details	-5
<b>Tail unit-assembly</b>	<b>OGL 54-5-1</b>
<b>Fittings</b>	<b>OGL 54-5-1</b>
<b>Controls</b>	<b>OGL 54-6-123</b>
<b>Rudder and brake pedal assembly</b>	<b>B-100</b>
<b>Wheel Installation</b>	<b>B-305</b>





# Aircraft Spruce & Specialty Co.

Phone: 1-877-4-SPRUCE | International: +951-372-9555

Dear Aviation Enthusiast,

Designing the "Baby Lakes" has always brought great satisfaction to the guys at Barney Oldfield Aircraft Company. It is a great little plane for the true enthusiast... responsive, flexible, and economical. Only one drawback limits what remains a real gem of an airplane. It is too small for two people or, in some cases, too small for a person with a large frame. Consequently, one comment is all too common... "Can't you make it a little larger? I wish that I could take my son or my wife along for a ride. They put up with a lot of aggravation so that I could build a plane to indulge my love of aerobatic flying. It would be nice if they could get some benefit."

When we decided to respond to this request, we discovered that this design challenge turned out to be a surprisingly easy one to resolve. To begin with, we knew that "Baby" had 100 pounds of payload that it never used. Designed to 9G's at an 850 pound payload, it rarely gets loaded beyond 750 pounds. With 10 more square feet of wing area, we could handle 100 more pounds (70 pounds of passenger and 30 pounds of airframe). Increasing the wing span from 16 feet to 18 feet and lengthening the fuselage by 11 inches and widening it by 4 inches, we could enlarge the "Baby" to accommodate two regular size people or one extra large person. It sounds simple but does it work?

Well it took some unusual seating and instrument arrangements, but it works fine. Seating for two people is similar to that of a motorcycle. This results in a single instrument panel, and only one joy stick located in the forward part of the cockpit with the pivots mounted several inches above the floor. A simple device lets you swivel the "S" shaped stick from front position to rear position to accommodate the pilot who flies it solo from the rear, or from the front, when carrying a

passenger. Yes, if you take your girlfriend along and want to fly from the rear, you'll have to stretch your arms around her to hold the joy stick! Two sets of rudder pedals and two throttle quadrants are standard. In other words, it's not a two place trainer, but an airplane to take someone along in, or to familiarize a person with before turning them loose in a single place Baby Lakes. This is truly the united way to fly!

We knew it would be a tight fit so we took it to Oshkosh for display and testing. Almost one thousand people tried the new "Buddy Lakes" on for size, and there were smiles of approval from everyone. The novel arrangement of the "Buddy Lakes" does work, and we are certain that persons who are interested in building a feisty, economical plane will find the "Buddy" to be the one to try. Consequently, we are rushing the initial plans out now so that you can get a head start.

In time, a full canopy will be available. We think the Buddy Baby to be a sensible, practical design for today's builder at yesterday's prices. Remember that over half the Buddy Lakes is standard Baby and Super Baby Lakes now. The wings, tail group, landing gear, wings tanks motor mounts, and firewall are fully interchangeable in all three aircrafts. The same applies to the Wood and Metal Materials packages. Only the Steel Tubing package is enlarged.

Harvey Swack  
Barney Oldfield Aircraft Company

## A QUESTION AND ANSWER SESSION WITH BARNEY OLDFIELD ABOUT HIS BABY GREAT LAKES ( THIS SESSION TOOK PLACE IN 1964).

**Q:** The first Baby Great Lakes is now a little over ten years old. Why did you wait until now before making plans available for others to build this airplane?

**B:** I intended to build only one airplane, but after seeing what planes there were available for amateurs, I thought perhaps this might be a better plane for them.

**Q:** What did you find after ten years history on this plane?

**B:** I found that people with as little as 20 solo hours in a Piper Club could fly this small bi-plane with complete safety. I also found that no complaints of any type showed up in flying this airplane during the last ten years. The Baby Great Lakes, Serial No.1, is reported to have over 1200 hours on it and it has been divided consistently past 200 miles an hour without experiencing any wing flutter or showing any unfavorable characteristics. You see, my primary interest in getting the plans for the Baby Great Lakes out is that I like to see people build an airplane that is pretty decent, can be made for a minimum cost, and is safe enough so the average pilot won't kill himself in it.

**Q:** What is the real story behind the airplane, Barney?

**B:** There is no real story behind the airplane, except that I have always wanted a small one since I was a kid. I think I covered that in my biography. As you well know, this airplane's performance is as good as the old Birds, Swallows, Fleets, etc. with three times the horsepower and two or three times the weight. So no more need be said about that.

**Q:** Was your overweight and size responsible for your selling your first Baby Great Lakes?

**B:** No, not by a long shot. To set the record straight "Other Aircraft Projects", not personal accumulation of weight was why I sold N9Y to John Long. My currently completed "Baby" is identical to N9Y and it holds my big 200 lb., 5-11 frame in a very comfortable fashion. Not only can I get into, and out of the cockpit easily, but I can stretch my legs out perfectly straight and relax the muscles on X-country flights. Many small bipes are notorious for providing so little room that leg cramps seem to be encouraged. This is not the case with the "Baby".

**Q:** What can you say about the Baby that indicates how strong you have made it?

**B:** Well, first of all, the size of the tubing and spars

are much greater than is necessary. Actually to make them no more than is actually required makes them of such small cross-section that they become extremely difficult to make and too fragile to handle. I used the biggest spars I could get in for the wing for that was standard and easily available namely  $\frac{5}{8}$ " diameter, with .035 wall thickness, which almost any wrecked airplane has a jillion feet of, in it. This means that you'd only have to buy the longerons if you were scrounging around for materials. When it comes to fittings, I can only say that they were taken to the Bell Aircraft testing laboratory during my time of employment there and we put them in the Baldwin Machine and pulled them apart at the lab. In every case, their strength exceeded our fondest expectations, the fittings were stronger than the wires that were hooked into them for the testing purposes. There was a slight elongation at the pin fittings, which was exactly as we calculated. Now these wires, which were 10-32 Mac-Whyte, fail at 2600 lbs. In actual flight, there is 550 lbs. distributed over the four flying wires or either left or right. This means that, assuming they are rigged in equal tension, this results in 125 lbs. on each wire, which wires carry a minimum of 2400 lbs. So that's that.

**Q:** Why the double landing and flying wires?

**B:** Part three of the CAM manual requires that all bracing on a 3-dimensional student of engineering can take the chordal section and see what happens here. I don't know.

**Q:** What recommendation would you make if someone wanted to use this airplane for aerobatic work?

**B:** Well, an A-80 engine, with a 190 inch Goodyear Camshaft that has the gear drive on the end for an Excello, or a high ejection system and a 65 inch paddle blade Aerobatic prop is all you need.\* The oil system will have to be inverted to give you a couple of minutes on her back. That is all I would suggest. If you do an extreme rate of climb and then you pull straight up, all you get is a prop stall long before the airplane is ready to give up flying. Your RPM stays constant, but your prop stalls. Hence an Aerobatic paddle blade would not do this. I can't see any excuse for using an engine larger than an A-65 or an A-75, in this aircraft. An 85 hp. Continental engine is more than enough, as the "Baby" cruises 120 mph using only 42 hp! A 65 hp engine would only shave the performance figures by about 10% at the most, are most easily obtainable and was the engine for which this aircraft was designed. It will out-perform most 85 to 125 biplanes with only a 65 hp engine.



# Aircraft Spruce & Specialty Co.

Phone: 1-877-4-SPRUCE | International: +951-372-9555

**Q:** You say that no jigs are required in building this aircraft, except for the wing jig. Why is this?

**B:** That's right. There are no other jigs required because this aircraft is built on a flat piece of plywood, or if you will, I prefer plasterboard. Plasterboard doesn't burn through when you are welding. You merely make a layout on it and clamp it on top of a couple of two-by-fours, which are straight. Then you build each side, tacking them together in the diagonals. Then you make each side, take them apart, space them on a couple of horses inverted, and then just tack in your cross members and square the thing up with an ordinary carpenter's square. That's all there is to it. It's parallel section back to the cockpit. After you tack this up, you lay it on its side and heat the longerons until they sag over the center line, and then you do this on the opposite side. Then you set it again inverted, and stretch a wire down the center of it, swinging the rudder posts until the center of the rear of the cockpit and the wire is centered at the firewall. Then you tack those together. That's all there is to making the fuselage square and true.

**Q:** Why is this airplane inexpensive to build?

**B:** The cost is moderate because there is actually only 136 feet of tubing in the fuselage proper. And that's it. First off, there's not much airplane here. Secondly, a smaller airplane requires no further explanation. It can be built in a minimum of time because it is as simple as I know how to make it. And here again, there are no expensive or complicated things to be made in this thing and there are no frills. There's really not much to it. There's a basic airframe, there's no upholstery, there's a reasonably neat instrument panel, there's nothing you don't need in this airplane. So you don't have to build a jig, all the fittings that are used in it, the tie-wire fittings, the landing wire fittings, they're all standard. The only special fittings would be the plates you saw off the land gear and the flying wire, and the landing wire attach fittings. That's all there is. The materials are available anywhere. The fuselage can be welded in one week or 40 man hours, using myself as the criterion for this. There are many pros and cons as to whether I work faster or slower than most people. You have your choice here.

**Q:** Is a complete description of how to build this airplane necessary and will it be provided?

**B:** A text is not required, but it is provided. This aircraft is no more complicated than any of the models you buy at a model shop to build. It is slightly larger, and I would say, somewhat simpler. But I would say this. In most cases, for the fellows who are going to build them, in every community there are welders who are excellent and love to work on these things. The preponderance of time is spent in fitting the tubing together. So I would suggest to all builders, unless they are excellent welders, to fit the tubing together

and call in a local welder or any good A&P welder and let him weld it up. I do not know of a single aircraft welder who would not be pleased to spend a couple of hours in the evening, once in a while, to weld on something that was properly fitted. And here again, any time you fit the tubing within a sixteenth of an inch, that's close enough. The actual idea of a hairline joint is not necessary, and in most cases, not desired.

**Q:** How much do you estimate the cost of materials to build a Baby Great Lakes, less the cost of the engine?

**B:** I say that this airplane can be built for under \$5,000 using all new materials, not including the engine and prop. Of course, if you are a good scrounger this cost could be reduced. The plans include full size drawings of the wing ribs and aircraft fittings. (1983 prices)

**Request a License Agreement for the  
Baby Great Lakes,  
Super Baby Lakes or the  
Buddy Baby Lakes  
by calling 877-4-SPRUCE  
(877)477-7823**



# Aircraft Spruce & Specialty Co.

Phone: 1-877-4-SPRUCE | International: +951-372-9555

In a message dated 7/17/00 8:47:24 PM, SpiralDragon13@aol.com writes:

<< To Whom It May Concern:

I recently received my information packet for the Super Baby Lakes airplane. It was very informative and helpful, however there are a couple of questions that I couldn't find the answers to inside of it. One is, I know it says that a canopy can be obtained for the Baby Lakes but it said nothing about the Super Baby Lakes. Can a Bubble type canopy be obtained for the Super Baby Lakes? Also, was I correct in reading that the Baby Lakes was stressed to over 9 pos and 9 neg G's? If so, I may be better off going with the Baby Lakes as opposed to the Super Baby Lakes. I kinda like the lines on the Baby Lakes better. And what type of prop do you recommend for either of the aircraft? I was thinking about a 3 blade composite constant speed for added performance and speed.

Thank you..Joel Alexander

>>

Dear Joel,

I would build the Super because then you can use engines of greater horsepower if you decide to do so. The Canopy for the Baby and Super are the same. The primary difference in the airplanes is that the stabilizer is stronger and the wings have Frieze type ailerons. You need these as the speed goes up the standard ailerons become stiffer in aerobatic maneuvers. The idea of trying a constant speed prop sounds like an idea to try but we are strong believers in keeping the weight down. If the prop doesn't add very much weight over the standard prop weight then try it. Frankly, the less things to go wrong are usually the best. You will love flying this airplane and over the years no one has designed a better flying one with the kind of performance this airplane gives you.

Have a Great Day!

Harvey Swack



# Aircraft Spruce & Specialty Co.

Phone: 1-877-4-SPRUCE | International: +951-372-9555

**From:** "Lynn Izard" <lizard@ctesc.net>  
**Date:** Tue, 31 Oct 2000 17:47:53 -0000  
**To:** <HSwack@aol.com>  
**Subject:** Re: Baby Lakes

Harvey, Thank you for the two replies to my questions. I have admired the original Baby Lakes airplane for more than thirty years. I also like the Buddy Baby Lakes design. I have read all the information packs that I could get my hands on, all of them state "if you make changes to the plans, call it something else." And if a person wants something different he should find another type of project. I am an aircraft mechanic of more than thirty years, also an IA, and I like to (and believe in) staying with the original design. That is why I contacted you.

And I am very happy you have the grace to respond.

Thanks very much,

Lynn Izard

----- Original Message -----

From: <HSwack@aol.com>

To: <lizard@ctesc.net>

Sent: Tuesday, October 31, 2000 4:37 PM

Subject: Baby Lakes

> Lynn,  
> I need to further explain few things about this aircraft design for your benefit.  
> First, Barney Oldfield was an engineer and a master mechanic. He invented  
> piles of things and was clever to boot. He designed the airplane to collapse  
> in a special sequence to protect the pilot in case of an accident. The proof  
> of the concept was when a woman ended up crashed in the first Baby "Lakes"  
> airplane. A DC-6 ran up it's engines when turning on the runway. She was in  
> the slipstream and of course the airplane flipped over and rolled into a  
> ball. She was not hurt but Barney was delighted because everything folded up  
> the way he designed it. Yes, he rebuilt the airplane. That is the reason you  
> don't change anything! Good airplane designers have to outthink what a  
> builder might do during construction and when flying the airplane that will  
> protect the pilot/builder from himself. I can't tell you how much testing we  
> did and Barney did to perfect this design.  
> Many times I would suggest to Barney another way to do something with this  
> design and he always had a ready answer as to why you should not do it. I am  
> sure there is someone out there who could improve the design but you would  
> have to be such a clever designer that I doubt one could be located.  
> Designing Biplanes is not an easy task. There are a number of homebuilt  
> biplanes in the market out there but many really don't fly well. The cost of  
> doing the engineering to investigate the design changes you asked about would  
> make the project so expensive that you could not afford it. I hope you  
> feel better with this explanation.  
>  
> Thanks again for writing.  
>  
> Harvey Swack  
>  
> The Great Lakes Guru



# Aircraft Spruce & Specialty Co.

Phone: 1-877-4-SPRUCE | International: +951-372-9555

---

**From:** GREATAIRPLANES@aol.com

**Date:** Tuesday, September 28, 2004 1:24 PM

**Subject:** Re: Sport Aircraft question

---

The Baby Lakes with 65 hp will cruise about 100 mph to 105 mph. It will land and stall at about 45 mph depending upon the empty weight. I say the airplane should weigh about 480 lb. but the only ones I ever saw weighed a little more. I think it will qualify but have asked the man who designed the Buddy Baby to verify what I think. It may be that something can be modified to meet those new standards. Anyway I'll know for sure when my engineering consultant answers me, Thanks for the inquiry,

Harvey Swack  
The Great Lakes guru





# Aircraft Spruce & Specialty Co.

Phone: 1-877-4-SPRUCE | International: +951-372-9555

## KIT #1 WOOD MATERIALS PACKAGE

P/N 02-03910

This package will enable you to start construction on your Baby Great Lakes, Super Baby or Buddy Baby Lakes Wings. Necessary epoxy glue and nails are included for wood parts assembly. The next recommended materials package is #2 containing the metal materials to make special wing parts and the leading edge covers. Package #3 contains wing standard hardware enabling you to complete your wing frames.

### SPRUCE LIST

QUANTITY.	SIZE / DESCRIPTION	USE
2	1" x 3 <sup>5</sup> / <sub>8</sub> x 8 <sup>1</sup> / <sub>2</sub> ft.	Main Spar, Upper
2	1" x 3 <sup>5</sup> / <sub>8</sub> x 6 <sup>1</sup> / <sub>2</sub> ft.	Main Spar, Lower
2	3/4 x 2 <sup>15</sup> / <sub>16</sub> x 8 <sup>1</sup> / <sub>2</sub> ft.	Rear Spar, Upper
2	3/4 x 2 <sup>15</sup> / <sub>16</sub> x 6 <sup>1</sup> / <sub>2</sub> ft.	Rear Spar, Lower
2	1/2 x 3 x 4 ft.	Spar, Aileron
94	1/4 x 1/4 x 3 ft. (Note: Up to 15% may be random lengths for truss pieces)	Truss Ribs
6	1/4 x 1/4 x 3 ft.	Aileron Capstrip
4	1/4 x 1/2 x 3 ft.	Capstrip
16	1/4 x 3/4 x 3 ft.	Capstrip
2	1/2 x 3/4 x 3 ft.	Butt Rib Compression Member
2	1/2 x 5/8 x 8 ft.	Leading Edge, Upper Wing
2	1/2 x 5/8 x 6 ft.	Leading Edge, Lower Wing
46 ft.	1/4 x 3/8 (Random Lengths)	Main Spar Filler Material
36 ft.	90° Corner Blocks, (Random Lengths)	Lower Wing
18 ft.	96° Corner Blocks, (Random Lengths)	Upper Wing
18 ft.	84° Corner Blocks, (Random Lengths)	Upper Wing
5	1/4 x 3/4 x 5 ft.	Turtleback Longerons
5	3/8 x 3/4 x 8 ft.	Longerons
2	5/8 x 1 <sup>3</sup> / <sub>4</sub> x 5 ft.	Longeron Cap

#### Plywood, Mahogany, 90°, Aircraft Grade

1 Piece	1/4" Thickness x 2 ft. x 4 ft.
1 Piece	1/8" Thickness x 2 ft. x 4 ft.
3 Pieces	1/16" Thickness x 2 ft. x 4 ft.

1 Quart of Epoxy Glue FPL-16A

1/2 Pound 1/4" x 20 Gauge Steel Aircraft Nails

1/2 Pound 1/2 x 20 Gauge Steel Aircraft Nails

Note : Wood lengths may be shipped in longer lengths than that specified as long as the quantity of the specified of the specified lengths can be cut from them.



## KIT #2

### WING METALS PACKAGE

P/N 01-10020

FOR BABY GREAT LAKES, SUPER BABY AND BUDDY BABY LAKES

<u>QUANTITY.</u>	<u>MATERIAL / SIZE</u>	<u>USE</u>
1 pc	.125 2x4 ft. - 2024T3	03-28750 Wing & Plate Fittings
2 pc.	.016 x 4 ft. x 8 ft. - 2024 T3	03-27720 Leading Edge Covers
4 pc.	1 1/4 wide x 8 ft.	03-48900 Alum Trailing Edges
4 pc.	1/2 x 1/2 x 1/16 x 7 ft. 6061T6	03-47700 Extruded Angle.- Leading Edge
4 pc.	1/2 x 1/2 x 1/16 x 6 ft. 6061T6	03-47700 Extruded Angle.- Leading Edge
1 pc.	3/4 x 3/4 x 1/8 x 2 ft. Length-6061T6	03-47900 Aileron Spigot Angle
8 pc.	3/16 dia. x 6 ft. 2024T3 Rod.	03-45500 Drag Wires
2 pc.	7/8 o.d. x .058 Wall x 6 ft. 2024T	03-33800 Compression Tube
4 pc.	5/8 o.d. x .065 Wall x 5 ft. 6061T6	03-36100 Wing Tips
1 pc.	5/8 o.d. x .065 Wall x 3 ft. 6061T6	03-36100 Upper Wing Center
6 pc.	.035 x 5/8 x 3 ft. Stainless Type 304 Annealed	03-16060 Drag Wire Fittings
1 pc.	3/4 o.d. x .065 Wall 4130 Steel Tube 3 ft. length required	03-04600 Aileron Tube

### PRE-MACHINED PARTS (SEE BELOW)

The pre-machined parts listed on the following page are those parts which require machine shop tool operations of mills or lathes not normally available to the average homebuilder . Also some of the parts require such small quantities not readily available .

<u>QUANTITY.</u>	<u>DESCRIPTION</u>	
2	Inner Aileron Hinge Bracket	P/N 01-10132
2	Outer Aileron Hinge Bracket	P/N 01-10131
2	Aileron hinge Spigots, Inboard	P/N 01-10114
2	Aileron Hinge Spigots, Outboard	P/N 01-10115
2	Aileron Hinge lock nut	P/N 01-10138
2	Outer Hinge Bearings	P/N 01-10117
2	Special hinge Spigot Bolts	P/N 01-10118
2	Oilite Bearings, 3/4 I.D. x 7/8 o.d. x 1"	P/N 01-10115A
20	Locators, Compression Tubes	P/N 01-10120
2	Aileron Torque Tube / Pivot Bearing	P/N 01-10124

(Note; Since these parts are specially machined, they are shipped in a separate package at a later date).



## KIT #3A

### WING STANDARD HARDWARE

### FOR BABY GREAT LAKES, SUPER BABY AND BUDDY BABY LAKES

P/N 01-10030

<u>QUANTITY</u>	<u>PART NUMBER</u>	<u>DESCRIPTION</u>
50	AN960-10	3/16 Washer
116	AN960-416	1/4 Washer
36	AN970-3	3/16 Wood Washer
20	AN365-1032A	10/32 Locking Nut
70	AN365-428A	1/4 - 28 Locking Nut
20	MS24694S94	1/4 - 28 x 7/16 Screw
12	AN3-13A	3/16 x 1 3/8 Bolt
12	AN4-14A	1/4 x 1 1/2 Bolt
22	AN4-15A	1/4 x 1 5/8 Bolt
12	AN4-16A	1/4 x 1 3/4 Bolt
24	AN4-17A	1/4 x 1 7/8 Bolt
8	AN3-15A	3/16 x 1 5/8 Bolt
40	AN315-3R	10/32 Hex Nut
100	Sheet Metal Screws, Type A, Truss Head, #4 x 1/4	THA 4 X 4
20	Sheet Metal Screws, Type a, Truss Head, #6 x 3/8	THA 6 X 6
2	AN502-10-6	Fillister Head Screw

**2 kits required per plane**



## KIT #3B

### WING HARDWARE PACKAGE FOR SUPER BABY AND BUDDY BABY LAKES (FRIESE AILERONS) P/N 01-10035

<u>QUANTITY</u>	<u>PART NUMBER</u>	<u>DESCRIPTION</u>
50	AN960-10	3/16 Washer
116	AN960-416	1/4 Washer
36	AN970-3	3/16 Wood Washer
20	AN365-1032A	10/32 Locking Nut
70	AN365-428A	1/4 - 28 Locking Nut
20	MS24694S94	1/4 - 28 x 7/16 Screw
4	AN3-13A	3/16 x 1 3/8 Bolt
20	AN4-14A	1/4 x 1 1/2 Bolt
22	AN4-15A	1/4 x 1 5/8 Bolt
12	AN4-16A	1/4 x 1 3/4 Bolt
24	AN4-17A	1/4 x 1 7/8 Bolt
8	AN3-15A	3/16 x 1 5/8 Bolt
40	AN315-3R	10/32 Hex Nut
100	Sheet Metal Screws, Type A, Truss Head, #4 x 1/4	THA 4 X 4
20	Sheet Metal Screws, Type a, Truss Head, #6 x 3/8	THA 6 X 6
2	AN502-10-6	Fillister Head Screw

**2 kits required per plane**



# Aircraft Spruce & Specialty Co.

Phone: 1-877-4-SPRUCE | International: +951-372-9555

## KIT #4A

### 4130 STEEL MATERIALS PACKAGE

### BABY GREAT LAKES P/N 03-14300

*This is the list of materials contained in the Steel Materials Package. This package, after the Baby Lakes Wing Materials Package, contains all steel stock size materials necessary to build the Baby Lakes Airplane. The correct type and sizes of welding rod is also included.*

The following is 4130 steel alloy, round seamless tubing, normalized, and per specification MIL-T6736.

<u>QUANTITY</u>	<u>SIZE / DESCRIPTION</u>	<u>USE</u>
4'	1 <sup>1</sup> / <sub>4</sub> o.d. x .058 Wall	Landing Gear
1'	1 <sup>1</sup> / <sub>8</sub> o.d. x .058 Wall	Landing Gear
2 ft.	1" o.d. x .058 Wall	Landing Gear
3 ft.	1" o.d. x .035 Wall	Wing Carry thru.
4 ft.	7 <sup>7</sup> / <sub>8</sub> o.d. x .065 Wall	Landing Gear & Misc.
2'	7 <sup>7</sup> / <sub>8</sub> o.d. x .065 Wall	Torque Tube
10 ft.	3 <sup>3</sup> / <sub>4</sub> o.d. x .035 Wall	Wing Carry thru & Tail
1 ft.	3 <sup>3</sup> / <sub>4</sub> o.d. x .065 Wall	Rudder Pedals
107 ft.	5 <sup>5</sup> / <sub>8</sub> o.d. x .035 Wall <i>(Note: 2 pieces to be 117" minimum length and 2 pieces to be 116" minimum length.)</i>	Fuselage & Misc.
12 ft.	5 <sup>5</sup> / <sub>8</sub> o.d. x .049 Wall	Engine Mount
5 ft.	5 <sup>5</sup> / <sub>8</sub> o.d. x .058 Wall	Landing Gear
2 ft.	5 <sup>5</sup> / <sub>8</sub> o.d. x .065 Wall	Pedals, etc.
1 ft.	5 <sup>5</sup> / <sub>8</sub> o.d. x .095 Wall <i>(Machining time is saved if 9<sup>9</sup>/<sub>16</sub> o.d. x .065 wall tube is installed instead.)</i>	Tail Support
50 ft.	1 <sup>1</sup> / <sub>2</sub> o.d. x .035 Wall	Fuselage, Tail
3 ft.	1 <sup>1</sup> / <sub>2</sub> o.d. x .065 Wall	Engine Mount, etc.
2 ft.	1 <sup>1</sup> / <sub>2</sub> o.d. x .095 Wall	Landing Gear & Struts
20 ft.	3 <sup>3</sup> / <sub>8</sub> o.d. x .035 Wall	Empennage
3 ft.	3 <sup>3</sup> / <sub>8</sub> o.d. x .065 Wall	Bushing Material
4 ft.	5 <sup>5</sup> / <sub>16</sub> o.d. x .065 Wall	Bushing Material
10 ft.	1 <sup>1</sup> / <sub>4</sub> o.d. x .035 Wall	Tail
1 ft.	1 <sup>1</sup> / <sub>2</sub> o.d. x .035 Wall	Interplane Struts

The following tubing is of the same alloy and specification as the above, except it is **square** instead of round.

7 ft.	5 <sup>5</sup> / <sub>8</sub> x 5 <sup>5</sup> / <sub>8</sub> Square x .035 Wall	Fuselage
6 ft.	1 <sup>1</sup> / <sub>2</sub> x 1 <sup>1</sup> / <sub>2</sub> Square x .035 Wall	Fuselage & Pedals

The following is 4130 Streamline tubing.

27 ft.	1.349 x 0571 x .049 Wall Note: Lengths must be able to be cut into: 2 pieces 31 <sup>1</sup> / <sub>2</sub> inches long 4 pieces 31 inches long 2 pieces 19 <sup>1</sup> / <sub>4</sub> inches long 2 pieces 18 <sup>1</sup> / <sub>4</sub> inches long 2 pieces 21 <sup>3</sup> / <sub>4</sub> inches long	Struts
--------	---	--------



## KIT #4B

### 4130 STEEL MATERIALS PACKAGE

### SUPER BABY LAKES P/N 03-14310

*This is the list of materials contained in the Steel Materials Package. This package, after the Baby Lakes Wing Materials Package, contains all steel stock size materials necessary to build the Baby Lakes Airplane. The correct type and sizes of welding rod is also included.*

The following is 4130 steel alloy, round seamless tubing, normalized, and per specification MIL-T6736.

<u>QUANTITY</u>	<u>SIZE / DESCRIPTION</u>	<u>USE</u>
4'	1 1/4 o.d. x .058 Wall	Landing Gear
1'	1 1/8 o.d. x .058 Wall	Landing Gear
2 ft.	1" o.d. x .058 Wall	Landing Gear
3 ft.	1" o.d. x .035 Wall	Wing Carry thru.
4 ft.	7/8 o.d. x .065 Wall	Landing Gear & Misc.
2'	7/8 o.d. x .065 Wall	Torque Tube
10 ft.	3/4 o.d. x .035 Wall	Wing Carry thru & Tail
1 ft.	3/4 o.d. x .065 Wall	Rudder Pedals
107 ft.	5/8 o.d. x .035 Wall <i>(Note: 2 pieces to be 117" minimum length and 2 pieces to be 116" minimum length.)</i>	Fuselage & Misc.
12 ft.	5/8 o.d. x .049 Wall	Engine Mount
5 ft.	5/8 o.d. x .058 Wall	Landing Gear
2 ft.	5/8 o.d. x .065 Wall	Pedals, etc.
1 ft.	5/8 o.d. x .095 Wall <i>(Machining time is saved if 9/16 o.d. x .065 wall tube is installed instead.)</i>	Tail Support
50 ft.	1/2 o.d. x .035 Wall	Fuselage, Tail
3 ft.	1/2 o.d. x .065 Wall	Engine Mount, etc.
2 ft.	1/2 o.d. x .095 Wall	Landing Gear & Struts
20 ft.	3/8 o.d. x .035 Wall	Empennage
3 ft.	3/8 o.d. x .065 Wall	Bushing Material
4 ft.	5/16 o.d. x .065 Wall	Bushing Material
10 ft.	1/4 o.d. x .035 Wall	Tail
1 ft.	1/2 o.d. x .035 Wall	Interplane Struts

The following tubing is of the same alloy and specification as the above, except it is **square** instead of round.

7 ft.	5/8 x 5/8 Square x .035 Wall	Fuselage
6 ft.	1/2 x 1/2 Square x .035 Wall	Fuselage & Pedals

The following is 4130 Streamline tubing.

27 ft.	1.349 x 0571 x .049 Wall Note: Lengths must be able to be cut into: 2 pieces 31 1/2 inches long 4 pieces 31 inches long 2 pieces 19 1/4 inches long 2 pieces 18 1/4 inches long 2 pieces 21 3/4 inches long	Struts
--------	---	--------





# Aircraft Spruce & Specialty Co.

Phone: 1-877-4-SPRUCE | International: +951-372-9555

4130 Steel Alloy Sheet per Specification MIL-S-18729C Normalized.

.040 Thickness	10 x 18 or Equivalent Size (Minimum)
.050 Thickness	9 x 9 or Equivalent Size (Minimum)
.063 Thickness	8 x 8 or Equivalent Size (Minimum)
.090 Thickness	18 x 36 Equivalent Size (Minimum)
.125 Thickness	4 <sup>1</sup> / <sub>2</sub> x 4 <sup>1</sup> / <sub>2</sub> (For Landing Gear Weld Washers)

4130 Steel Bar - per Specification MIL-S-18729C Normalized.

1/2 inch dia.	1 Foot Length
7/8 inch dia.	1 Foot Length

4130 Steel Sheet

.032 Thickness x 18 x 18 For Empennage & Landing Gear ribs  
*(Note: Keep this piece marked and separate from the 4130 steel sheet so it is not inadvertently used when 4130 steel is specified.)*

Welding Rod 32 CMS

1/16 dia.	5 lbs. required
3/32 dia.	2 lbs. required

The following items must be added to this package for the **Super Baby Lakes**;

- A. 1/4 o.d. x .035 wall 4130 Steel Tubing Add 16' more. A total requirement of 25' is needed.
- B. Add: 1 1/16" o.d. x .065 wall x 6" 4130 Steel tubing. Two six ft. lengths are required.
- C. Add: 3/4" o.d. x .035 wall 4130 Steel tubing. Two 6 ft. lengths are required.

Reason; Super Baby Lakes requires use of a stabilizer spar per drawing 54-4-1A instead of the standard Baby Lakes Stabilizer.



**KIT #4C**  
**BUDDY BABY LAKES**  
**4130 STEEL MATERIALS PACKAGE**  
**P/N 03-14320**

*This is the list of materials contained in the Steel Materials Package. It contains all steel stock size materials necessary to build the Buddy Baby Lakes Airplane. The correct type and sizes of welding rod is also included.*

The following is 4130 steel alloy, round seamless tubing, normalized, and per specification MIL-T6736.

<u>QUANTITY</u>	<u>SIZE / DESCRIPTION</u>	<u>USE</u>
44 in.	1 <sup>1</sup> / <sub>4</sub> o.d. x .058 Wall	Landing Gear
3 in.	1 <sup>1</sup> / <sub>8</sub> o.d. x .058 Wall	Landing Gear
2 ft. 6 in.	1 o.d. x .058 Wall	Landing Gear
4 ft.	1 o.d. x .035 Wall	Wing Carry thru.
8 <sup>1</sup> / <sub>2</sub> ft.	7 <sup>7</sup> / <sub>8</sub> o.d. x .065 Wall	Landing Gear & Misc.
18 ft.	3 <sup>3</sup> / <sub>4</sub> o.d. x .035 Wall	Wing carry thru & Tail
2 ft.	3 <sup>3</sup> / <sub>4</sub> o.d. x .049 Wall	
6 in..	3 <sup>3</sup> / <sub>4</sub> o.d. x .156 Wall	
1 ft.	3 <sup>3</sup> / <sub>4</sub> o.d. x .065 Wall	Rudder Pedals
100 ft.	5 <sup>5</sup> / <sub>8</sub> o.d. x .035 Wall <i>(Note: Four of the pieces to be 11 ft. minimum length)</i>	Fuselage & Misc.
12 ft.	5 <sup>5</sup> / <sub>8</sub> o.d. x .049 Wall	Engine Mount
5 ft.	5 <sup>5</sup> / <sub>8</sub> o.d. x .058 Wall	Landing Gear
2 ft.	5 <sup>5</sup> / <sub>8</sub> o.d. x .065 Wall	Pedals, etc.
80 ft.	1 <sup>1</sup> / <sub>2</sub> o.d. x .035 Wall	Fuselage & Tail
3 ft.	1 <sup>1</sup> / <sub>2</sub> o.d. x .065 Wall	Engine Mount
2 ft.	1 <sup>1</sup> / <sub>2</sub> o.d. x .095 Wall	Landing Gear & Struts.
20 ft.	3 <sup>3</sup> / <sub>8</sub> o.d. x .035 Wall	Tail
3 ft.	3 <sup>3</sup> / <sub>8</sub> o.d. x .065 Wall	Bushing Material
2 ft.	5 <sup>5</sup> / <sub>16</sub> o.d. x .065 Wall	Bushing Material
22 ft.	1 <sup>1</sup> / <sub>4</sub> o.d. x .035 Wall	Tail
1 ft.	1 <sup>1</sup> / <sub>16</sub> " o.d. x .120 Wall	

The following tubing is of the same alloy and specification as the above, except it is **square** instead of round.

8 ft.	5 <sup>5</sup> / <sub>8</sub> x 5 <sup>5</sup> / <sub>8</sub> Square x .035 Wall	Fuselage
2 ft.	1 <sup>1</sup> / <sub>2</sub> x 1 <sup>1</sup> / <sub>2</sub> Square x .035 Wall	Pedals
12 ft.	3 <sup>3</sup> / <sub>4</sub> x 3 <sup>3</sup> / <sub>4</sub> Square x .035 Wall	Fuselage

The following is 4130 Streamline tubing.

20 ft.	1.349 x .571 x .049 Wall 6 pcs. "N" struts. 33" long
3 <sup>1</sup> / <sub>2</sub> ft.	2.023 x .857 x .049 Wall 2 pcs. Spar Carry Thru 20" long
10 ft.	1.500 x .571 x .035 (O.K. to substitute 1.349) Cabane Cut to following lengths: 4 pcs 18", 2 pcs. 24"



# Aircraft Spruce & Specialty Co.

Phone: 1-877-4-SPRUCE | International: +951-372-9555

4130 Steel Alloy Sheet per Specification MIL-S-18729C Normalized.

.040 Thickness	18 x 18 or Equivalent Size (Minimum)
.050 Thickness	9 x 9 or Equivalent Size (Minimum)
.063 Thickness	18 x 18 or Equivalent Size (Minimum)
.090 Thickness	18 x 36 Equivalent Size (Minimum)
.125 Thickness	6" x 12" (For Landing Gear Weld Washers)

4130 Steel Bar - per Specification MIL-S-18729C Normalized.

1/2 inch dia.	1 Foot Length	20700
7/8 inch dia.	1 Foot Length	21100

4130 Steel Sheet

.032 Thickness x 18 x 18 For Empennage & Landing Gear ribs 22525  
*(Note: Keep this piece marked and separate from the 4130 steel sheet so it is not inadvertently used when 4130 steel is specified.)*

Welding Rod 32 CMS

1/16 dia.	5 lbs. required	03-27000
3/32 dia.	2 lbs. required	03-27100



## KIT #5

### BABY GREAT LAKES, AND SUPER BABY LAKES LANDING GEAR / BRAKES MATERIAL PACKAGE P/N 01-10040

The list is for the Baby Lake Landing Gear Materials Package. After use of the Baby Lakes Wing and Steel Materials Packages, this third materials package (Landing Gear) will enable you to construct and install your landing gear with steering brakes.

The builder may opt for installing or not installing Parking brakes. For this reason, the flexible hoses are omitted. If you do plan to use the Parking feature, in addition to the steering brakes, you should purchase a double parking brake valve and install it on the aft side of the station "O" framing.

QUANTITY	MATERIAL DESCRIPTION	USE
1 set	5.00 x 5 Wheel and Brake Assemblies with Brake flange	199 - 102
2	5.00 x 5 Tires McCreary Air Trac 6 ply	06-08200
2	5.00 x 5 Inner Tubes McCreary	06-08300
2	Cleveland Brake Master Cylinders	Model 10 - 19
2	Reservoir units for the master brake cylinders	A-315
2	Axles, Threaded, 1 <sup>1</sup> / <sub>4</sub> o.d. 500 x 5 Bolt on	11701
4	Spacers, wheel	11716
2	Nuts, Axle	06-11800
1	Tailwheel leaf spring - J3 type or equivalent	06-14200

*Note: The tailwheel assembly is omitted to permit the builder to choose the make and type. A tailwheel assembly with locking capability is recommended for the Baby Lakes. Steerable only and fixed types are alternates which have been used at the option of some builders. For this reason, the connecting steering springs are also omitted.*

2 Springs, Pedal Return, 4<sup>1</sup>/<sub>2</sub> inches long.

2	AN3-5A	Bolt	Tail Wheel Clamp Attachment
6	AN3-7	Bolt	Rudder Pedal Assembly
2	AN3-10	Bolt	Rudder Pedal Assembly
2	AN3-11	Bolt	Rudder Pedal Assembly
8	AN4-5A	Bolt	Brake Attachment
6	AN4-13	Bolt	Landing Gear Attachment
4	AN4-14A	Bolt	Shock Strut
2	AN4-15A	Bolt	Shock Strut
2	AN4-17	Bolt	Landing Gear Assembly
1	AN6-15A	Bolt	Tail Wheel Spring Attachment
1	AN6-7A	Bolt	Tail Wheel Assembly Attachment
10	AN310-3	Nut, Castle	
8	AN310-4	Nut, Castle	
14	AN365-428A	Nut, Elastic Stop	
8	AN365-1032A	Nut, Elastic Stop	

4 ft.	Alum. Tube,	5052-0, 1 <sup>1</sup> / <sub>4</sub> o.d.	Brake Line
4	AN817-4D	Sleeve (AN818-4D, 819-4D)	
4	AN818-4D	Nut	
2	AN924-4D	Nut, Bulkhead	
2	AN837-4D	Fitting, 45° Elbow	
2	AN491-5	Nut	
4	MS21919-DG4	Clamp	
2	AN816-4D	Nipple	
2	AN822-4D	Elbow, 90°	

18	MS24665-155	Cotter Pin	
2	MS24665-377	Cotter Pin	Axle Nut
4	AN526-1032-8	Machine Screw	



# Aircraft Spruce & Specialty Co.

Phone: 1-877-4-SPRUCE | International: +951-372-9555

## KIT #6

### BABY GREAT LAKES, SUPER BABY, BUDDY BABY LAKES WING ALIGNMENT MATERIALS PACKAGE P/N 01-10050

*This list is for the special machined parts and standard hardware necessary to set up the wings and stabilizers with the fuselage. These items will enable you to take the necessary measurements for ordering your landing, flying and tail brace wires, plus aligning your aileron torque tube with the fuselage.*

*The flying, landing and tail wires may be ordered thru Aircraft Spruce & Specialty Co. These wires are manufactured on order and to your furnished dimensions, allow a couple of months for delivery.*

<u>QUANTITY</u>	<u>SIZE / DESCRIPTION</u>	<u>USE</u>
<b><u>Special Machined Parts</u></b>		
8	Clevis	01-10121 Interplane Struts
4	Block Clevis, Forward	01-10122 Interplane Struts
4	Block Clevis, Aft	01-10123 Interplane Struts
2	5/8 Dia. x 1/2 long Bronze Rod-Aileron Torque Tube / Fuselage Pivot Bearing	01-10124
<b><u>Standard Parts</u></b>		
4	AN3-6A Bolt	Cabane Attachment
8	AN3-7A Bolt	Clevis / Block Clevis Attachment
4	AN3-14A Bolt	Interplane Strut Attachment Aft
4	AN3-16A Bolt	Interplane Strut Attachment Fwd.
2	AN4-10A Bolt	Aileron Torque Tube Pivot Bearing
4	AN4-15A Bolt	Wing Attachment, Aft Spar
4	AN4-17A Bolt	Wing Attachment, Fwd. Spar
20	AN365-1032 Nut, Elastic Stop	
10	AN365-428 Nut, Elastic Stop	



## KIT #7

### BABY GREAT LAKES AND SUPER BABY LAKES FUEL TANK INSTALLATION PACKAGE

P/N 01-10060

Materials in this package list will enable the builder to install the tank, vent line and fuel line up to the firewall fittings.

Note: The Baby Lakes fuselage fuel tank is made in either the regular or long fuselage version per the customer's order. Each tank is equipped with welded fitting bosses and filler cap as required for aerobatic or non-aerobatic use, optional visual sight gage, or optional additional wing tanks and header tank.

QUANTITY		SIZE / DESCRIPTION	USE
1	P/N 01-10125	Tank, Fuselage (Buyer to specify regular or long version)	
1	P/N 01-10070	Fuel Tank Installation Kit	

## KIT #7A

P/N 01-10070

### Installation Kit only - No Tank Included

1		Strainer, Finger, 3/8 male 1/4 female pipe threads	03-17700
1		Valve, Shut off - #103 - 1/4 male 1/4 female threads	103HD-04404
1		AN3-6 Bolt	Fuel Shut Off
1		AN310-3 Nut, Castle	Fuel Shut Off
1		AN381-1-12 Cotter Pin	Fuel Shut Off
1		AN315-3 Jam Nut	Fuel Shut Off
2		AN315-4 Jam Nut	Tank Support Rods
2		AN365-428 Nut, Elastic Stop	Tank Support Rods
1		AN665-21R Threaded Clevis	Fuel Shut Off Rod
1		AN818-4D Nut	Vent Line
1		AN819-4D Sleeve	Vent Line
1		AN822-4D Elbow	Vent Line
1		AN842-6D Elbow	Fuel Line
1		AN913-2D Plug	Optional Tank Use
2 ft.	3/8 I.D.	Fuel Hose (MIL-H-6000 or Equivalent)	6000-6
2	3/4 Dia.	Hose Clamp (QS100-M10W or Equivalent)	
2	1/4 o.d. x 36"	4130 Steel Rod	Tank Support 03-20300
2 ft.	3/16 Dia.	6061 T-6 Alum. Rod	Fuel Shut Off Rod 03-45500
3 ft.	1/4 o.d. x .035	Wall 5052-0 Tube	Vent Line 03-39300





# Aircraft Spruce & Specialty Co.

Phone: 1-877-4-SPRUCE | International: +951-372-9555

## KIT #8

### BABY GREAT LAKES AND SUPER BABY LAKES FLYING CONTROLS MATERIALS PACKAGE P/N 01-10080

After previous packages, this materials package will enable the builder to install the trim and flying controls.

QUANTITY	SIZE / DESCRIPTION	USE
<u>Finish Machined Parts</u>		
1	P/N 01-10126 Trim Lead Screw	Trim Assembly
1	P/N 01-10127 Pulley Assembly	Trim Assembly
2	P/N 01-10128 Bushing, Flanged Bronze	Trim Assembly
1	P/N 01-10137 Yoke, Control Stick with tube stick	Trim Assembly
<u>Standard Hardware</u>		
1	AN3-4 Bolt	
8	AN3-6 Bolt	
3	AN3-7 Bolt	
1	AN3-11 Bolt	
4	AN3-10A Bolt	
4	AN3-11A Bolt	
2	AN3-12A Bolt	
2	AN3-14A Bolt	
1	AN3-15 Bolt	
2	AN3-20A Bolt	(Rudder Hinge - To be reworked)
1	AN3-34A Bolt	(Elevator Hinge - To be reworked)
1	AN4-10 Bolt	
7	AN4-11 Bolt	
1	AN4-16 Bolt	
2	AN4-16A Bolt	(Elevator Hinge - To be reworked)
1	AN4-23 Bolt	
2	AN5-30A Bolt	(Pivot, Torque Tube - To be reworked)
4	Heim Bearing, Female Thread #F34-16 or Equivalent.	
14	AN310-3 Nut, Castle	
9	AN310-4 Nut, Castle	
4	AN316-4R Nut, Plain	
10	A-120 Pulley, 3" dia.	
3	MS24566-3B Pulley	
2	MS24566-4B Pulley	(Use one pulley for trim cord)
3	A223 Pulley	
2	AN140-16S Turnbuckle	
4	AN130-16S Turnbuckle	
1	AN43-13 Eyebolt	
4	AN161-16S Fork end, turnbuckle	
12	AN100C-4 Thimble	
12	#28-3-M Nicropress Sleeves	
8	AN115-21 Shackle	
8	AN393-11 Clevis Pin	
25	1/16 x 1" Stainless Cotter Pin	
2	Springs, Tension - 4 1/2 length	Rudder Pedal Return 01-27300
1 ft.	1/2" dia. Nylon Rod	Fairleads 03-51800
1	1/4 dia. x 9" long 4130 steel rod.	Heim Bearing Connect 03-20300
2 ft.	3/8 o.d. x 1/4 i.d. - 2024T3 Alum Tubing	03-32200

#### Items not included in Flying Controls Materials Package

1	1/4 x 2 x 2 Micarta (Ref Dwg. 54-3, Sheet 2)	
2	Rudder Cable Assemblies - 1/8 x 7 x 19	Stainless Cable
	11 feet long, with Swaged Fork fitting on one end.	
36 ft.	Stainless Cable, 3/8 x 7 x 19	



## KIT #9

### BABY GREAT LAKES AND SUPER BABY LAKES FAIRINGS, FIREWALL, INSTRUMENT & FUSELAGE PANELS AND MOTOR MOUNT TO FIREWALL HARDWARE PACKAGE P/N 01-10090

Materials in this package will enable the builder to make and attach fit the subject items. Fit and install fuselage stringers first. Follow with the firewall and instrument panel and then the fuselage panels. The wing fairing panels can be fitted before or after fabric covering.

Cockpit furnishing items and cockpit edging material are not included to permit builder option. Builder may order specific items such as flying / landing wires, engine, cowling, propeller, spinner, exhaust stacks, etc. from Aircraft Spruce & Specialty Co.

<u>QUANTITY</u>	<u>MATERIAL DESCRIPTION</u>	<u>USE</u>
1	.040 x 24" x 24	2024T3 Aluminum Instrument Panel
1	.025 x 48 x 8 ft.	2024T3 Aluminum Fuselage Panels
1	.016 x 48 x 48	2024T3 Aluminum Wing Fairings
1	.012 or .016 x 25 x 27	Type 301 Stainless Firewall
2	1" x 1" x 1/8 x 4 ft.	6061T6 Alum. Angle Firewall
1	1" x 1" x 1/8 x 3 ft.	6061T6 Alum. Angle Installation Panel
4	AN6-31	Bolt Engine Mount Attach.
4	AN310-6	Castle Nut Engine Mount Attach.
8	AN960-616	Washer Engine Mount Attach.
24	AN526-832-12	Machine Screws Stringer Attachment
24	AN365-832	Elastic Stop Nut Stringer Attachment
24	AN960-8	Washer Stringer Attachment
2	AN526-1032-8	Machine Screw Instrument Panel Attach.
2	An365-1032	Elastic Stop Nut Instrument Panel Attach.
75	K1000-08	Anchor Nut Joining Fuselage Panels etc.
150	AN960PD-8L	Washers Under Heads of Attach Screws
36	#4 x 1/2	THA 4 X 8 Sheet Metal Screws-Type A-Truss Hd. - Attachment of Panels to Wood Longerons and Aft Wood Bulkhead.
60	#4 x 3/8	THA 4 X 6 Sheet Metal Screws-Type A-Truss Hd. - Attachment of Wing Fairings.
75	AN470AD-4-4	Rivets Firewall & Inst. Panel
10	AN426AD-4-4	Rivets Firewall & Inst. Panel
10	AN426AD-4-5	Rivets Firewall & Inst. Panel
1/4 lb.	AN426AD-3-3	Rivets Anchor Nut Attachment



## KIT #10

### BABY GREAT LAKES AND SUPER BABY LAKES COVERING MATERIALS PACKAGE P/N 01-10095

The Covering Materials Package for the Baby Lakes does not include liquids. The builder should order the covering liquids of his choice of aircraft make, and where applicable, color. At the end of this list, a typical amount of liquids, when the Stits process is used, is listed.

<u>QUANTITY</u>	<u>MATERIAL DESCRIPTION</u>	
1	Set of Poly Fiber Baby Lakes P103 envelopes consisting of:	P/N 09-69080-3
1	Fuselage fabric sewn envelope (includes fin)	
2	Upper Wing sewn fabric envelope	
2	Lower Wing sewn fabric envelope	
2	Stabilizer sewn fabric envelope	
2	elevator sewn fabric envelope	
2	Aileron sewn fabric envelope	
	Sufficient excess material is included to cover the landing gear strut assembly.	
4	Rolls-2" wide pinked fabric tape	P/N 09-02500
1	Roll 1 1/2 wide pinked fabric tape	P/N 09-02400
1	Roll 3/8 wide reinforcing tape	P/N 09-03600
1	Roll Rib stitching cord	P/N 09-03800
1	Needle 12"	P/N 09-18720
12	Inspection Rings	P/N 09-19200
12	Inspection Ring Patches	P/N 09-18750
60	Drain Grommets	P/N AN231-1
12	Inspection Plates	P/N 09-19300
1	Procedure Manual	P/N 09-06000
3 qt.	Poly-Tak	P/N 09-05000
6 gal.	Poly-Brush	P/N 09-04200
8 gal.	Poly-Spray	P/N 09-04500
3 gal.	Poly-Fiber Reducer R 65-75	P/N 09-04800
6-8 gal.	Poly-Tone or	
6 gal.	Aerothane	

**(Price Does not Include Poly-Tone or Aerothane colors)**

*Ceconite / Dope Covering Package Quote Available Upon Request —*

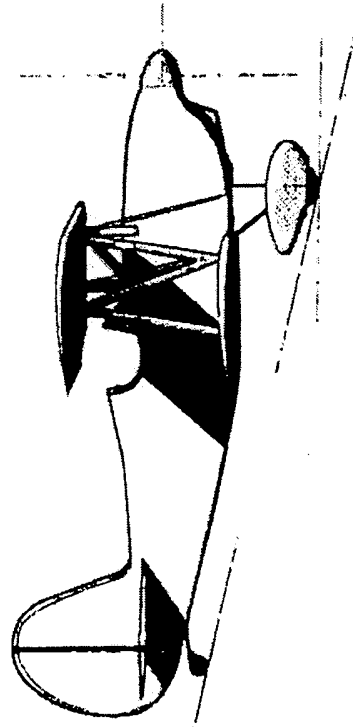
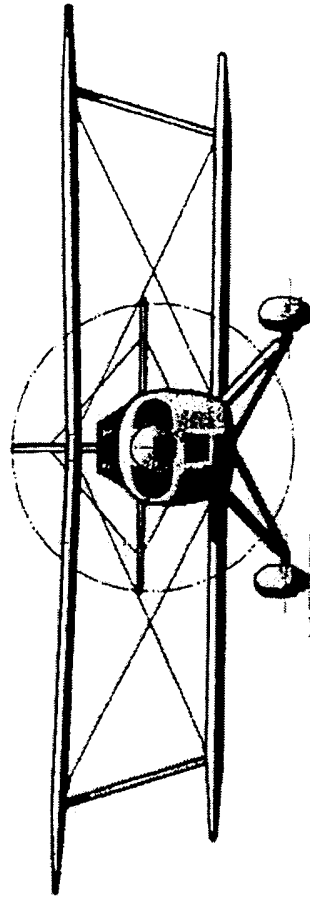
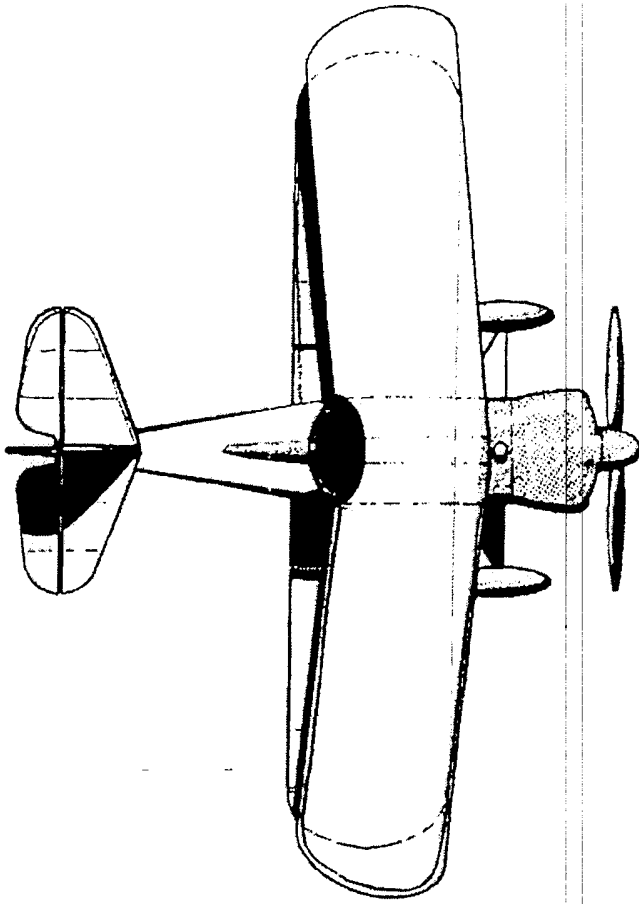

## Super Baby Lakes

Landing Speed: 55 MPH    Span: 16' 8"  
 Cruise Speed: 135 MPH    Height: 4' 6"  
 Top Speed: 155 MPH    Length: 13' 6"



Empty Wt.: 510 LBS.  
 Gross Wt.: 850 LBS.  
 Stressed: 9G's ±

Rate of Climb: 3000 F.P.M. (1st Min.)

Power Plant: Lycoming 115 (108 125)



Barney Oldfield Aircraft Company P.O. Box 3974, Cleveland, Ohio 44101

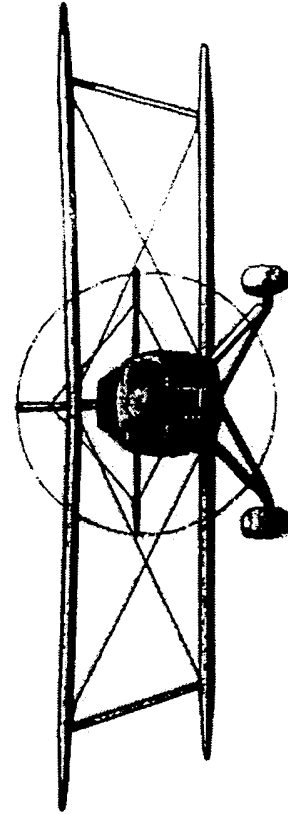
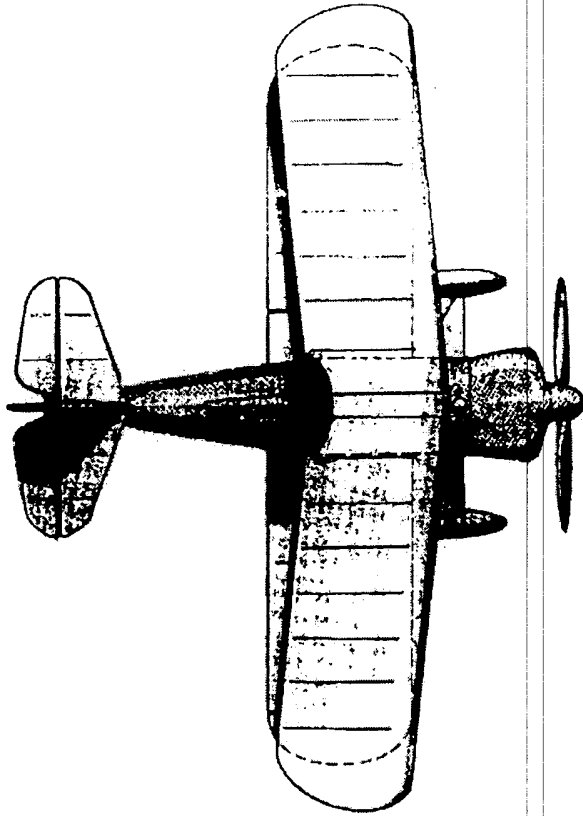

## BABY LAKES

**Landing Speed: 50 MPH**    **Span: 16' 8"**  
**Cruise Speed: 118 MPH**    **Height: 4' 6"**  
**Top Speed: 135 MPH**        **Length: 13' 6"**  
**Empty Wt.: 400 LBS.**  
**Gross Wt. 850 LBS.**  
**Stressed: 9 G's**



**Rate of Climb: 2000 P.P.M. (1st Min.)**  
**Power Plant: Continental A-20**

1' 2' 3' 4' 5' 6' 7' 8' 9' 10'

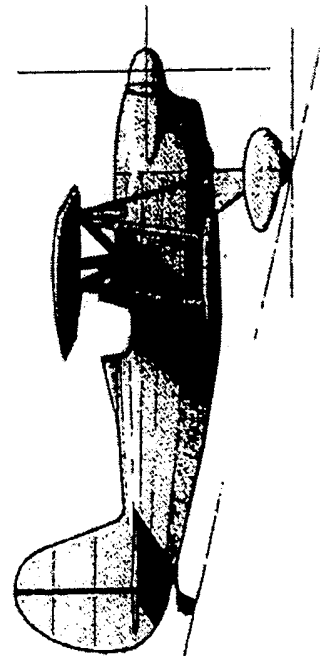

**Barney Oldfield Aircraft Company**

Barney Oldfield Aircraft Company P.O. Box 228 Needham, MA 02192

P.O. Box 228

Barney Oldfield Aircraft Company

**BUDY BABY LAKES**

LANDING SPEED 55 MPH. SPAN 18'0"

CRUISE SPEED 118 MPH. HEIGHT 6'3"

TOP SPEED 135 MPH. LENGTH 14'8"

EMPTY WT. 535 LBS.

GROSS WT. 1000 LBS.

RATE OF CLIMB 2000 FPM (WITH PILOT ONLY)

POWER PLANT 65 to 125 H.P.

1' 2' 3' 4' 5' 6' 7' 8' 9' 10'

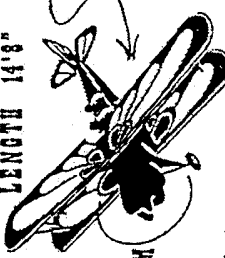

I USED "CHIFFONARD" (THIN CARBON) TO STRENGTHEN MY PLANE, THEN TRAELED IT ON THE FOUR SURFACES OF THE WINGS.

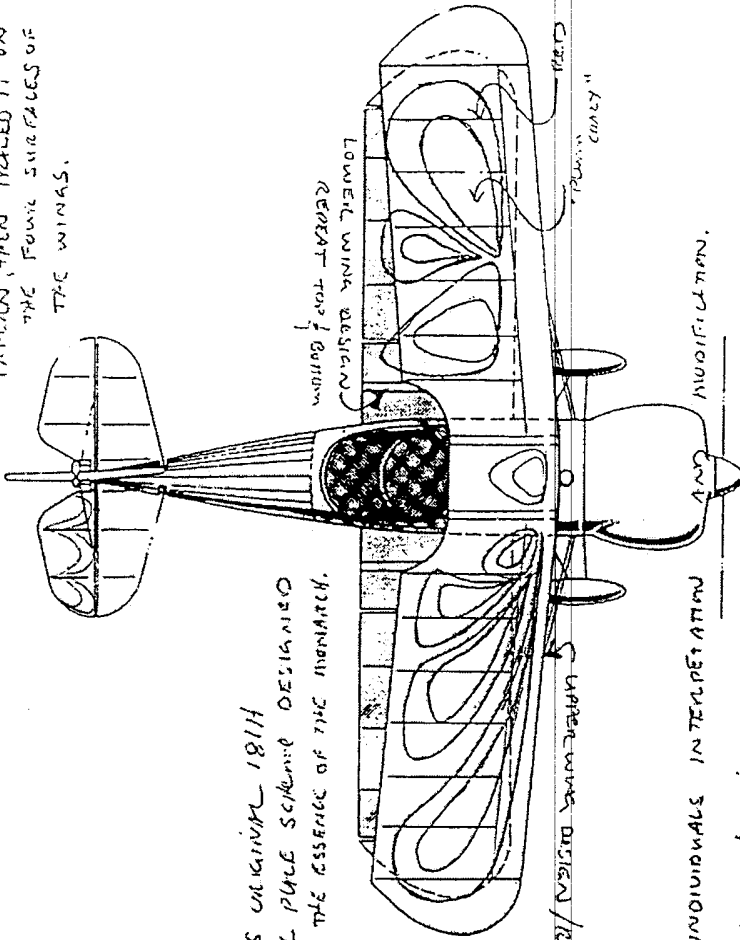

THIS IS ORIGINAL 1811H SINGLE PLACE SCHEMATIC DESIGNED TO CAPTURE THE ESSENCE OF THE MONARCH.

WINGS FOR LIFT / REAR / DESIGN / MONARCH

THIS DESIGN IS SUPPOSED TO REFLECT THE "ESSENCE" OF A BUTTERFLY, NOT ANY PARTICULAR ONE. THEREFORE, IT IS OPEN FOR EACH INDIVIDUALS INTERPRETATION AND MODIFICATIONS.

FUSelage WAS PAINTED IN A "FACE-OUT" STRIPES WITH PURE BLUE ON SPINACIL AND FADING "PLUMM CREEPY" PURPLE FROM FRONT TO GAUL WITH THE TAIL ENDING UP PURE WHITE.

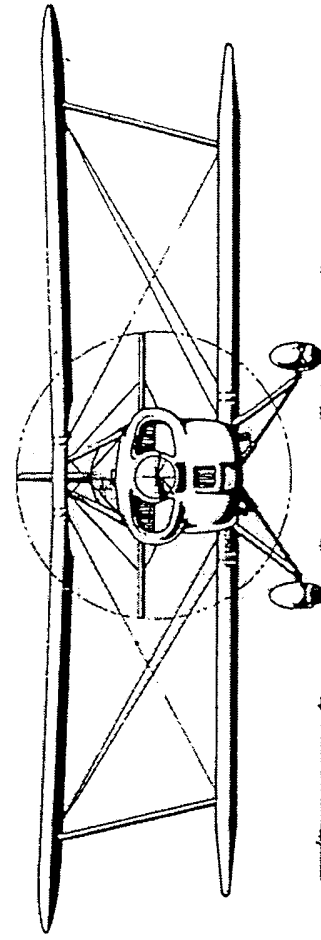
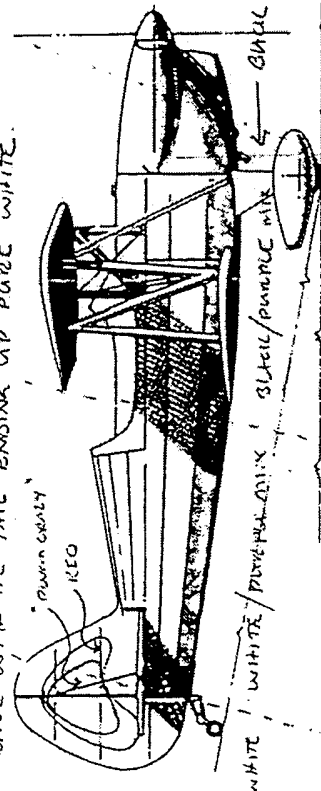

"PLUMM CREEPY" IS A CHARACTER PRODUCT COLOR FROM EARLY '70'S



# Aircraft Spruce & Specialty Co.

Phone: 1-877-4-SPRUCE | International: +951-372-9555

10-11-86

Dear Harvey,

Just a note to let you know about the meet up in Jaffrey, N.H. There were ten competitors in Sportsman. There were several Pitts Specials, a couple Decathalons and one 150 hp Smith Miniplane. I believe 762 was the only airplane without inverted systems. There was alot of good natured kidding aobut the size of the airplane, of course, but by and large everybody was happy to see a new type in competition.

Several people comented on the importance of inexpensive airplanes to give more people access to competition and I was always quick to point out the small amount I paid for mine. Everyone was truly impressed by the performance on 85 hp.

The final results, as you know, were, I finished second. The final score for the first place winner was 1837.2 to my 1836.2. ONE POINT! He flew a Pitts as did the third place pilot. I also won the highest first place finisher award!

All in all I was pretty happy with the results. It certianly shows that the airplane is capable of good Sportsman aerobatics. especially in light of the fact that it was my very first contest!

I'm hoping to fly in the Orange Co. contest next spring. My work schedule knocked me out of the N.J. contest.

Take care and if anyone out there wants fly a Baby Lakes in Sportsman, give him a push.

Sincerely

Eddie Ruhl